

**PERCEPTIONS AND EXPERIENCES OF INFORMAL CAREGIVERS RELATED TO
THE ROLE OF SOCIAL SUPPORT WHILE CARING FOR STROKE VICTIMS**

by

Zara Sajwani

DISSERTATION

Submitted in partial fulfillment of the requirements for the degree of

Doctor of Philosophy in Nursing

The University of Texas at Arlington

December 2021

Arlington, Texas

Supervising Committee:

Kathryn Daniel, Committee Chair

Deborah Behan

Chad Swank

Copyright © by
Zara Sajwani
2021

ACKNOWLEDGEMENTS

The Ferne C. Kyba Fellowship Endowment Award from the University of Texas at Arlington helped to pay for the financial expenses involved in this study.

ABSTRACT

PERCEPTIONS AND EXPERIENCES OF INFORMAL CAREGIVERS RELATED TO THE ROLE OF SOCIAL SUPPORT WHILE CARING FOR STROKE VICTIMS

Zara Sajwani, Ph.D.

University of Texas at Arlington, 2021

Supervising Professor: Kathryn Daniel

There are many expectations and responsibilities associated with stroke caregiving. The influence of social support on coping with stressors of stroke caregiving is important to explore. Using Pearlin's Stress Theory of caregiving, this research aimed to explore experiences of stroke caregivers related to their role expectations. It also revealed the availability and nature of social support for stroke family caregivers.

The researcher applied a qualitative phenomenological descriptive exploratory design for this study. The participants were recruited from support groups. Semi-structured interviews were conducted along with demographic data collection. There were ten informal caregivers of stroke patients that participated in the interviews. Manual inductive approach was used to analyze the transcribed the data from the interviews.

Seven themes which emerged from the data were work life balance, reaction of other people or family to stroke, expectations and responsibilities from caregivers, impact of stroke on abilities of victims, strategies used by caregivers to cope with stress, social support to stroke caregiver and care recipient, and break for caregivers. The study revealed change in the quality

and availability of social support with time and situation of caregivers. Caregivers needed a tangible and emotional support system to be able to effectively perform the caregiving role. Nursing research and practice can utilize the conclusions from this study to assist caregivers to achieve better outcomes for stroke victims and themselves.

TABLE OF CONTENTS

ACKNOWLEDGEMENTS.....	i
ABSTRACT.....	ii-iii
CHAPTER 1.....	1
Introduction: Background and Significance of the Problem.....	1
Theoretical Framework.....	4
Relationship among the Key Concepts.....	9
Rationale for Selecting the Pearlin’s Stress Theory.....	9
Method and its Philosophical Perspective.....	10
Research Study Questions.....	10
Statement of the Purpose.....	10
Statement of Essential Assumptions.....	10
Summary of Chapter.....	11
CHAPTER 2.....	12
Critical Review of Relevant Literature: Introduction.....	12
Search Strategy.....	12
Population of Interest.....	12
Background and Significance of the Health Problem or Phenomenon of Concern....	15
Caregiver Stress and its Reasons.....	17
Caregiver Coping.....	21
Social Support and Caregiving Outcomes.....	25

Social Support and Caregiving Outcomes: Burden and Depression.....	26
Summary.....	28
Gap in Literature.....	29
CHAPTER 3.....	31
Methodology, Study Design, and Procedures: Introduction.....	31
Study Design and Method.....	31
Study Setting, Recruitment, Procedure, Data Collection Method.....	31
Sampling.....	32
Screening Criteria.....	33
Data Collection.....	34
Data Analysis.....	35
Benefits and Risks.....	37
Ethical Measures.....	37
Rigor.....	38
Delimitations.....	40
Summary.....	40
CHAPTER 4.....	41
Study Results.....	41
Demographic Characteristics.....	41
Themes.....	44

Conclusion of Results Chapter.....	62
CHAPTER 5.....	63
Introduction.....	63
Discussion.....	63
Limitations.....	72
Conclusions.....	73
Implication for Nursing Practice and Nursing Research.....	75
Summary.....	77

APPENDIX A	
Script for Recruitment or Invitation Script.....	93
APPENDIX B	
Flyer.....	94
APPENDIX C	
Screening Script.....	95
APPENDIX D	
Script for Verbal Consent.....	96
APPENDIX E	
Data Collection Tools.....	97
APPENDIX F	
Process Log.....	99
APPENDIX G	
IRB Approval Letter.....	100

CHAPTER ONE

Introduction: Background and Significance of the Problem

Having a caregiver is necessary for many individuals after experiencing a stroke. Stroke is caused by disruption in blood flow of brain vessels (American Stroke Association, 2021). In the United States, it is a known cause of fatality and debility (American Stroke Association, 2021). There are two main types of strokes: hemorrhagic stroke and ischemic stroke (American Stroke Association, 2021). Hemorrhagic stroke is caused when a vessel bleeds in the brain and results in lessened blood circulation to previously healthy functional brain tissue (American Stroke Association, 2021). Ischemic stroke is caused when blood circulation to the brain is hindered due to a blocked vessel (American Stroke Association, 2021). The brain is a major organ that regulates the functionality of other parts of the body, such as controlling body movements, managing sensory perceptions, swallowing, etc. Therefore, stroke can negatively impact functions throughout the body (American Stroke Association, 2021). Stroke-related changes can cause reduced functionality or loss of function altogether. This makes a stroke survivor depend on others for help with day-to-day activities, such as brushing teeth, getting dressed, and taking care of hygiene. Not many studies reported the impact of stroke victim dependency on caregivers' life aspects.

Informal caregiving is a provision of unpaid help by caregivers to fulfil the needs of a care recipient (John Hopkins, 2021), whereas formal caregiving is given by trained personnel that provide paid care. Formal caregiving may end due to fulfilled medical needs or financial constraints. For example, financial constraints may include lack of insurance coverage, limited access to resources, or inability to afford paid services. After discharge from an institution where the formal caregiver is providing all care after an acute stroke event, caregiving becomes

the prime duty of informal caregivers (Lutz et al., 2016). The informal caregivers can be a long-term challenging commitment. However, not many studies have explored stroke caregiver perceptions and experiences on their stressors and caregiving responsibilities along the long-term stroke care continuum. This called for a need to understand if and how the caregiving responsibilities and stressors change along the stroke trajectory.

Caregivers should be prepared to manage the changes in functionality and cognitive status of stroke victims (Lutz et al., 2017), which is the mental and intellectual ability of stroke victims. Caregiving can lead to physical, social, economic, emotional, and mental stressors for the caregiver (Pesantes et al., 2017). Caregiving tasks done for the stroke victim may include brushing teeth, helping to bathe, dress, and other daily activities a person may need. This can be reason for physical strain stroke caregivers experience (Kaur et al., 2018). Restricted physical abilities of stroke victims can contribute to high caregiver strain (Fadilah & Rahariyani, 2019). A stroke can limit a caregivers' independence to be socially active and engaged themselves (Bucki et al., 2019) because of the caregiving commitment to spend time with the care recipient. Being in a tedious caregiving cycle can also be emotionally and mentally exhausting. Hence, caregiving can take a toll on different aspects of a caregiver's life. The nature of stressors can be subject to change depending on the phase of stroke caregiving. Few studies were found that explored different stressors in phases of caregiving.

To ease the strain of caregiving responsibilities, caregivers may need assistance themselves, which may come from their social network (Fadila et al., 2019; Pearlin et al., 1990). Social support can be provided to meet material and/or emotional needs of an individual (Erler et al., 2019). Social support is the assistance available to caregivers from their social network ties that is found to be linked with positive outcomes for caregivers (Kelly et al., 2017; Zhong et al.,

2020). Additionally, perceived social support available to stroke caregivers can affect the apparent burden of care provision (Akosile et al., 2018; Tosun & Temel, 2017).

The means of social support include friends, family, religious community, social groups, communal circles, and significant others (Erler et al., 2019). Formal social support comes from professionals, such as nurses and doctors (Shiba et al., 2016). An informal social support includes unpaid aid from caregivers such as friends, relatives, and family of caregivers (Shiba et al., 2016). According to Tosun and Temel (2017) support from family was found to be the paramount source of social support available to caregivers. Moreover, the family sub-scale of social support measures were found to be related to scores reflecting the caregiving burden (Akosile et al., 2018). An informal support system has a crucial role to support emotional and physical needs of the caregivers while fulfilling the caregiving role. However, there were not many naturalistic inquiry-based studies that explored informal social support resources utilized by stroke caregivers. There was a need to explore the influence of informal social support on stroke caregiving experiences. This helped to understand informal social support and the impact of informal social support on caregiver accomplishments and outcomes.

Pearlin's caregiving theory, an established conceptual framework to explore the stress of caregivers of persons with long-term illness, has not yet been applied much to stroke caregivers. This called for a need to conduct an open-inquiry phenomenological study that can provide an opportunity for stroke caregivers to share their experiences on stroke stressors, social support, and coping process. In the context of Pearlin's theory, this study focused on stressors of informal stroke caregivers on the stroke care continuum and explored the role of informal social support on caregiving experiences.

Theoretical Framework

Pearlin's Stress Theory

Pearlin's stress theory was proposed as a conceptual framework on caregiving and stress (Pearlin et al., 1990; Refer Figure 1). This theory is specific to caregiving, and it elaborates the processes and dynamics involved in caregiving of patients with chronic conditions or disabilities. Caregiver stress and burden are identified conceptions in literature. Pearlin's theory comprehensively takes into consideration the key concepts related to the phenomenon of caregiving stress.

Figure 1: Pearlin et al. (1990)

Pearlin's Stress Theory

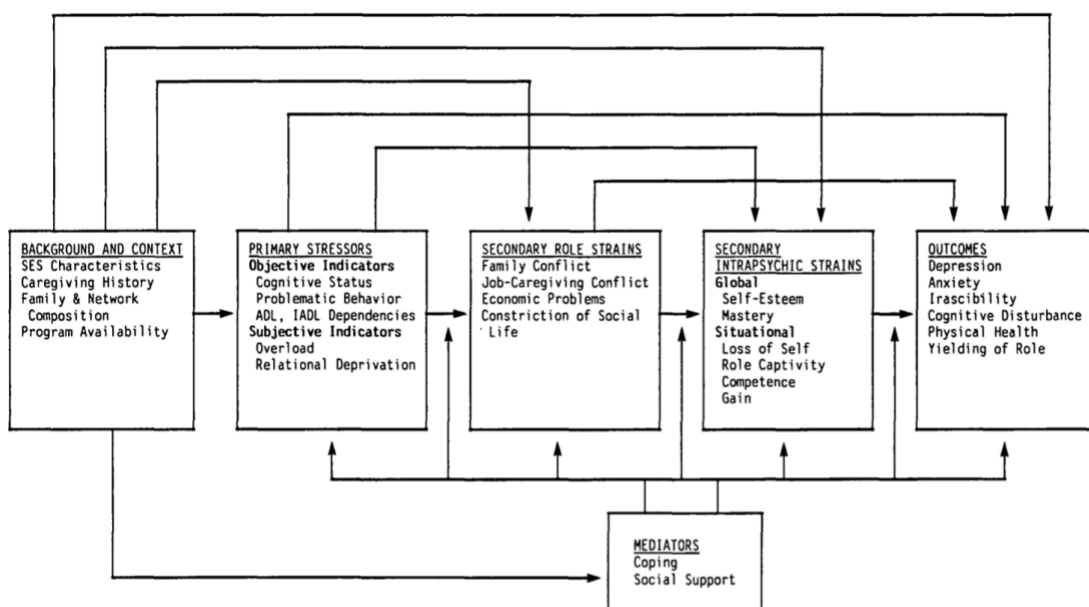

Figure 1. A conceptual model of Alzheimer's caregivers' stress. The stress process is made up of four domains: the background and context of stress; the stressors; the mediators of stress; and the outcomes or manifestations of stress.

Theorist- Leonard I. Pearlin

Pearlin's Stress Theory was developed by Leonard I. Pearlin (Pearlin, 2010). He was born in 1924 (University of California, San Francisco (UCSF), 2014). He was a recognized

social scientist who worked to explore the social processes associated with issues of mental health and aging (UCSF, 2014). He graduated in 1956 with a PhD degree from Columbia University (UCSF, 2014). He worked at the University of Maryland; moreover, he served as an esteemed professor at UCSF (UCSF, 2014). He also worked at the National Institute of Mental Health in the role of a researcher (UCSF, 2014). For his academic and scholarly accomplishments, he received recognition and accolades from the Gerontological Society of America and the American Sociological Association (UCSF, 2014).

Development of Pearlin's Stress Theory

Pearlin's stress theory is considered a middle range theory (Bolden & Wicks, 2008). This theory was generated by examining general caregiver stress dynamics and exploring the stress of caregivers of persons with the long-term illness of Alzheimer's disease (Pearlin et al., 1990). This theory was produced from a study which was conducted on 555 Alzheimer's caregivers from the Los Angeles and San Francisco Bay Area (Pearlin et al., 1990). This theory was applied to numerous caregiver groups including general caregivers (Khalaila & Cohen, 2016), Alzheimer's Disease caregivers (Park et al., 2015; Pearlin et al., 1990), dementia caregivers (Liu et al., 2017), general mental illness caregivers (Mulud & McCarthy, 2017), caregivers of liver transplant patients (Bolden & Wicks, 2008), and caregivers of other long-term health conditions such as Parkinson's disease and stroke (Brinda et al., 2014).

Constructs and Concepts in Pearlin's Stress Theory

There are six major constructs of this theory: background and context, primary stressors, secondary roles strains, secondary intrapsychic strains, mediators, and outcomes (Pearlin et al., 1990). The arrows in the theoretical framework represent the relationships and associations among the constructs.

Background and Context. The construct of background and context covers the concepts of economic standing, experience of caregiver, family dynamics (Pearlin et al., 1990), and other personal demographic traits of caregivers (Khalaila & Cohen, 2016). These determined traits explain the differences among individuals in terms of their duties, advantages, remunerations and resources (Pearlin et al., 1990). These background traits can impact caregiver stress processes (Pearlin et al., 1990) and outcomes (Mulud & McCarthy, 2017; Pearlin et al., 1990).

Primary Stressors. Primary stressors are directly related to the cause of caregiving. Primary stressors are linked to the health status of care recipients and burden of caregiving associated with care recipients' status (Pearlin et al., 1990). It includes subjective and objective markers (Pearlin et al., 1990). Subjective marker or indicators explain the perception of being overwhelmed as well as negative changes in relationships (Pearlin et al., 1990). Objective indicators are physical and cognitive changes in the health status of the care recipient (Pearlin et al., 1990). The objective indicators relate to the disease, which can lead to increased dependence by patients on family caregivers in performing activities of daily living (ADLs) and instrumental activities of daily living (IADLs, Pearlin et al., 1990).

Secondary Role Strain. This construct includes friction with other relations, difficulty in meeting job requirements due to caregiving, and challenges in financial and social spheres (Pearlin et al., 1990). These strains are secondary to caregiving challenges and are caused by the demands of other roles and responsibilities not directly related to caregiving (Pearlin et al., 1990). When a caregiver is involved in caregiving tasks it can lead to strain on other aspects of life, thereby producing stress and conflict. For example, maintaining expectations in other relations and fulfilling job responsibilities are not direct issues of caregiving, but they derive or

stem from caregiving stress (Pearlin et al., 1990). Like primary stressors, secondary strains have a tendency to alter caregiver results (Pearlin et al., 1990).

Secondary Intrapsychic Strains. This is another construct that entails secondary stressors and includes the concepts of lack of caregiving mastery, lack of self-confidence, lack of role competence, and high sense of captivity (Pearlin et al., 1990). Intrapsychic strains or traits can serve as additional stressors and precursors that determine an individual's vulnerability to the burden of caregiving (Pearlin et al., 1990). Mastery and self-esteem are deemed as global intrapsychic strains because they are not specific to a situation (Pearlin et al., 1990). It explains an individual's conviction, ability and self-confidence to deal with issues of strength and resilience (Pearlin, 2010). Whereas situational intrapsychic strains are context specific stressors that explain inclination of an individual being captive or lack of competency in a new role (Pearlin et al., 1990). Not being able to skillfully perform the caregiver role or feeling overwhelmed in this role are situational intrapsychic strains (Pearlin et al., 1990). These types of secondary strains are ultimate and significant precursors to the final outcome construct (Pearlin et al., 1990).

Mediators. This construct is comprised of two main concepts: coping and social support (Pearlin et al., 1990). These mediating variables impact primary and secondary stressors and can alter the outcome reaction to a stressor (Pearlin et al., 1990). Some caregivers may react differently to the stress of caregiving because of these intermediary variables (Pearlin et al., 1990). Research on the stress process may undermine the value of mediators, whereby the impact of these mediators on caregiving outcomes may not be fully explored (Pearlin et al., 1990).

Coping is an individual's reaction and attitude to deal with a stress (Pearlin et al., 1990). Coping strategies may include active problem solving, acknowledging the situation, acquiring social network help, and managing emotional reactions (Khalaila & Cohen, 2016). Additionally, response and coping with stress can vary among individuals. They may have adaptive or maladaptive coping mechanisms.

Social support is another intermediary variable or a resource that can obstruct or minimize additional strains (Pearlin et al., 1990). There are two types of social support explained in this theory, they are emotional and instrumental (Pearlin et al., 1990). Emotional also referred to as expressive social support helps to deal with emotional turmoil caused by the stressor and provides emotional strength to caregivers (Pearlin et al., 1990). Instrumental social support helps to solve the actual problem by providing physical or material support (Pearlin et al., 1990). Both types of social support are very important and can provide a source of strength for caregivers of patients with chronic health conditions.

Outcomes. This construct incorporates concepts, such as role yielding and physical and mental health outcomes (Pearlin et al., 1990). Yielding of roles means assigning caregiving tasks to others either by involving helper(s) or by institutionalization of the patient (Pearlin et al., 1990). Mental health outcomes encompass depression, anxiety, and cognitive issues (Pearlin et al., 1990). Physical health outcomes of caregivers involve bodily harm caused by being involved in caregiving responsibilities (Pearlin et al., 1990). Additionally, it can also involve the inability to physically perform typical tasks (Pearlin et al., 1990).

Caregiver's health can suffer as a result of their caregiving role. A quantitative study on stroke caregivers revealed that the depressive symptoms of caregivers was linked to lower quality of life (QOL) of the care recipients (Fei et al., 2017). Depression of caregivers can affect

their mental health scores ($p=0.004$) as well as physical health scores ($p<0.001$; Fei et al., 2017). The caregivers may not seek early professional help for their own caregiving issues. The primary point of concern is usually the care recipient, but the health and well-being of caregivers is equally important. By caring for caregivers, the burden on our health system can be curtailed in the long run.

Relationship among the Key Concepts

For this study, the concepts of social support and coping are the key phenomena that will be addressed in this study. According to the Pearlin et al. (1990) graphical model, the construct of background and context impacts the mediators (social support and coping). Moreover, these mediating concepts influences all other constructs of primary stressors, secondary stressors, secondary intrapsychic stressors, and caregiving outcomes (Pearlin et al., 1990).

Mediator resources of social support and coping can not only directly influence the care outcomes, but also it can indirectly influence the stressors (Pearlin et al., 1990). Moreover, these mediators can serve to inhibit the link or relation between the primary strains and secondary strains (Pearlin et al., 1990). Measures to enhance these mediating variables can aid in facilitating better caregiver outcomes (Pearlin et al., 1990). Therefore, it was essential to explore the role of social support and coping in dealing with caregiving issues.

Rationale for Selecting the Pearlin's Stress Theory

Pearlin's stress theory best explained the phenomenon of interest, and this theory supports the evidence gathered by this study.

- This theory is specifically developed by studying caregiver issues (Pearlin et al., 1990).
- It takes into account the needs of caregivers involved in caregiving of illnesses that can cause long-term disability (Brinda et al., 2014; Pearlin et al., 1990).

- The constructs of this theory cover the holistic aspect of the caregiving process. For example, antecedents, process indicators, and outcomes are all covered in this study (Pearlin et al., 1990).

Method and its Philosophical Perspective

This study utilized a qualitative paradigm to unveil lived experiences of stroke caregivers on their exploration of their roles and responsibilities as a caregiver and utilization of the social network available to them. This methodology will help with in-depth exploration of the experiences of the caregivers to be better be able to understand the caregiving concepts discussed in Pearlin's theory.

Research Study Questions

The research questions of this study were:

- 1- How is Pearlin Stress Theory applicable for stroke caregiver population?
- 2- What are the roles of stroke caregivers through the care trajectory?
- 3- What is the influence of social support on the perceptions and experiences of informal stroke caregivers?

Statement of the Purpose

The purposes of this study were to:

- 1- Analyze the application of Pearlin Stress Theory for stroke caregivers
- 2- Identify roles and responsibilities of stroke caregivers through the care trajectory.
- 3- Explore the perceptions and experiences of informal stroke caregivers related to informal social support.

Statement of Essential Assumptions

The assumptions for stroke caregiver population of this study included that:

- 1- The researcher's only assumption in utilizing Pearlin's framework was that all informal caregivers cared for or were concerned for the care recipients. In capacity of a caregiver, they had a sense of engagement in caregiving process.
- 2- Stroke caregivers were able to share their experiences of caregiving even if their care recipients were not alive at the time of interview.
- 3- Caregivers were open to share their lived experiences on the phenomenon of interest.

Summary of Chapter

It is important to understand the impact of informal social network of family or informal caregivers on the experiences of caregiving. This author utilized Pearlin's Stress Theory to understand the stress of caregiving and role social support. Descriptive exploratory approach was used to answer the identified research purpose and understand the dynamics of social support available to caregivers after the incident of stroke.

CHAPTER TWO

Critical Review of Relevant Literature

Introduction

In this qualitative study, views of stroke caregivers were studied on the impact of social support on caregiving stressors and responsibilities.

The purpose of this review of the literature is to highlight the importance of social support available to informal stroke caregivers to deal with the stressors of caregiving. This chapter addresses the severity of stress associated with stroke caregiving and coping mechanism used by caregivers. It also entails description of the types of social support and influence of social support on patient and caregiving outcomes.

Search Strategy

Cumulative Index to Nursing and Allied Health Literature (CINAHL) Complete, PubMed, and Google Scholar were searched for authentic articles published in the last five to six years from 2015 to 2020. Relevant keywords were used to conduct this review, such as “stroke”, “caregiving”, “social support”, “social network”, “stress”, “coping”. There were 16,415 articles found from the above-listed databases out of which total of 38 relevant sources were added in this review. One primary seminal article published in 1990 was also used in this review.

Review of Relevant Literature

Population of Interest

Informal caregivers are the family or friends who provide voluntary or unpaid care and assistance to a victim affected by a debilitating health condition (John Hopkins, n.d.). It is necessary to study related demographic characteristics of informal caregivers. In the United States, caregivers made up about 21.3% (53.0 million) of the total population in a year (National

Alliance for Caregiving (NAC) & American Association of Retired Persons (AARP), 2020). In a survey of 1,392 participants, those in the age group between 18 years and 34 years comprised 24% of the caregiver group (NAC & AARP, 2020). Data from this survey found that the age group from 35 years to 64 years constituted 58% of the unpaid caregiver group (NAC & AARP, 2020). About 19% of the caregiver population belonged to the age group of 65 years and above (NAC & AARP, 2020). For caregivers in general, their mean age was found to be nearly 49 years (John Hopkins, n.d.; NAC & AARP, 2020). The study by Lutz et al. (2017), was a qualitative study based on 40 informal stroke caregivers. Particularly for stroke caregivers, the average age of stroke caregivers was found to be 60.6 years (age range between 23 and 89 years) in the sample of caregivers in the study (Lutz et al., 2017). However, no recent studies with large sample size were found on the demographic characteristics of stroke caregiver population in the U.S.

In terms of gender, women are dominantly associated with caregiving tasks (John Hopkins, n.d.; NAC & AARP, 2020). They made up the majority (61%) of the caregiver group (NAC & AARP, 2020). Men also served as informal care providers comprising 39% of the caregiver group (NAC & AARP, 2020). Similar results were found in a study conducted in the U.S. particularly on the stroke caregivers mentioned that majority (72.5%) of the respondents were females (Lutz et al., 2017). Nevertheless, this study by Lutz et al. (2017) has limited sample size considering its qualitative nature, which calls for a need to have a study on stroke caregivers with a bigger sample size on their sociodemographic traits. Regarding gender dynamics and caregiver stress, Menon et al. (2017) study was conducted longitudinal research on 201 stroke caregivers. The survey was composed on 22 questions on caregiver burden (Menon et al., 2017). It was revealed that as compared to male stroke caregivers, female stroke

caregivers experienced more caregiver strain ($p = 0.018$) with chi-square of 11.931 and invested more time on care provision ($p = 0.002$) and chi-square of 15.199 (Menon et al., 2017). Since, caregiving is ingrained in fabric of cultural and societal norms, there was a dire need to explore the role of gender on stroke caregiving experiences. Our study contributed to exploration of the impact of gender on roles and responsibilities of stroke caregivers.

In a quantitative survey on large representative sample size of 1,392 general caregivers of the U.S., caregivers revealed their relationship with the care recipients (NAC & AARP, 2020). It was found that 89% of the care recipients were related to caregivers (NAC & AARP, 2020). Parents or parent-in-law made up 50% of the care recipient population, grandparents or grandparent-in-law comprised 8%, adult child comprised 6%, spouse or significant other made up 12%, sibling/ sibling-in-law constituted 7%, other relatives made up nearly 6%, and non-relatives (neighbors, friends, etc.) constituted approximately 10 percent of the care recipient group (NAC & AARP, 2020).

Particularly for stroke caregivers that include relatives, such as spouse, children, parents, and siblings, take the responsibility of caregiving (Menon et al., 2017). Similar results were found in Lutz et al. (2017) research on 40 stroke family or informal caregivers that 67.5% of the caregivers were spouses of stroke victims, 30% were children/ children-in-law, and 2.5% were parents of stroke victims. Appraisal of above-mentioned studies reflected that immediate family members and close relatives are primary caretakers of stroke survivors. Hence, this study enrolled family caregivers of stroke victims to inquire about their caregiving experiences.

According to the NAC and AARP (2020) report of 1,392 U.S. caregivers, about 32% of the general caregivers were high school graduates or had educational attainment lower than that. The remaining had at least some or complete college education, practical skills/training, or

attended a university (NAC & AARP, 2020). The NAC and AARP survey report (2020) also revealed categorization of caregivers based on their ethnic and racial grouping that includes Hispanics (17%), Caucasians (61%), Asian Americans (5%), and African American (14%), other groups (3%, NAC & AARP, 2020). Similarly in the study by Lutz et al. (2017), stroke victim-caregiver dyads were comprised of Caucasians (78%), Black Americans (18%), and other ethnic groups (4%). The statistics mentioned above regarding educational backgrounds and racial groups reflect the diversity of the caregiver group in the U.S. Hence, our study aimed to recruit caregivers from diverse support groups to try to enroll culturally representative sample of stroke caregivers.

Background and Significance of the Health Problem or Phenomenon of Concern

Every year, stroke impacts 800,000 individuals in the U.S. (Family Caregiver Alliance (FCA), 2020). In the U.S., the event of stroke is experienced by somebody every 40 seconds (American Heart Association (AHA), 2020). According to Lutz et al. (2017), the average age of persons who suffer a stroke was found to be 68.5 years (ranging from 33 to 84 years). According to unpublished National Heart Lung and Blood Institute (NHLBI) as cited in AHA (2020), the occurrence of stroke in the U.S. for adults 20 years of age and older was found to be 2.5% (7,000,000) from 2013 to 2016. It contributes to annual mortality of nearly 137,000 victims (FCA, 2020). Stroke-related deaths were 146,383 in 2017 (NHLBI unpublished as cited in AHA, 2020). These statistics highlight the prevalence and burden of mortality related to stroke.

Stroke is a known reason that contributes to the burden of dependency and debility around the globe (FCA, 2020; Menon et al., 2017). It may alter the victim's independence, physical strength, communication, ability to maintain balance, memory, vision, cognition, and behavior (FCA, 2020; Lutz et al., 2017; Sato et al., 2017), therefore caring for an individual with

stroke is a difficult task (FCA, 2020). Stroke is among the recognized causes that require a care recipient to seek a caregiver's support (FCA, 2020; NAC & AARP, 2020). Frailty and incapacity of the survivors inclines their friends and/or family to support them in Activities of Daily Living (ADLs) and Instrumental Activities of Daily Living (IADLs, FCA, 2020; Llanque et al., 2016). In a quantitative survey conducted on 1,392 U.S. caregivers, more than half of them expressed that they were bound to assume caregiver role (NAC & AARP, 2020). Each week a mean of 23.7 hours was invested on unpaid care activities (NAC & AARP, 2020), and they have been involved in the caregiver role for about four and a half years (NAC & AARP, 2020). Similar results were found for caregivers of older adults with stroke in a national study on beneficiaries of Medicare on large sample of 892 stroke patients and 892 participants in the control group (Skolarus et al., 2016). The weekly mean of 22.3 hours was invested to provide care for a stroke survivor (Skolarus et al., 2016). This mean was found to be statistically significant ($p < 0.01$) in comparison with counterparts without stroke (Skolarus et al., 2016). Therefore, it is difficult for stroke caregivers to find adequate time and support for fulfilling caregiving responsibilities (Lutz et al., 2017; Moon, 2017).

The fiscal burden of stroke caregiving on our society further represents the magnitude and severity of the problem. The expense accounted by stroke was estimated to be 45.5 billion dollars in 2014-2015 (Unpublished NHLBI as cited in AHA, 2020). Likewise, it was found in a national study that each year stroke has led to 45.5% (18.2 billion U.S. dollars) of the total expense (40 billion U.S. dollars) that was used for informal caregiving of older adults with stroke (Skolarus et al., 2016). As compared to other chronic cardiovascular illnesses, the financial burden of stroke caregiving is among the highest with an investment of 30.5 billion U.S. dollars in 2015 (AHA, 2018). This policy statement by AHA reported that this value is anticipated to

increase to \$37.2 billion in 2020, \$45.5 billion in 2025, \$55.5 billion in 2030, and \$66.3 billion in 2035 (AHA, 2018).

Caregiver Stress and its Reasons

Caregivers are unpaid care providers who look after dependent survivors after devastating injury or illness. The strain on family caregivers while taking care of an individual affected with a long-term medical condition is known as caregiver stress (FCA, 2020; Katbamna et al., 2017; Llanque et al., 2016; Pearlin 1990). Stroke is a chronic illness that can be a source of stress for informal caregivers. There are several reasons of stress identified in stroke caregiving literature including emotional suffering (Camicia et al., 2019; Pesantes et al., 2017), economic burden (American Heart Association AHA, 2018; Menon et al., 2017; Pesantes et al., 2017), disturbed social life (Pesantes et al., 2017), and physical stress (Camicia et al., 2019; Llanque et al., 2016; Lutz et al., 2017).

Among different types of stressors mentioned-above, emotional turmoil is also identified in literature (Camicia et al., 2019; Pesantes et al., 2017). A mixed-methods research was conducted on identifying the requirements of informal stroke caregivers while patients' stay in stroke rehabilitation unit (Camicia et al., 2019). Interviews, Family Inventory of Needs scale, and art therapy was utilized on a small convenient sample of 12 subjects to serve the study purpose (Camicia et al., 2019). Emotional stress for family and their need of emotional support was identified as one of the major themes, and the caregivers reported being emotionally exhausted and getting drained at the end of the day (Camicia et al., 2019). However, this study was conducted while the stroke patients were still admitted in the rehabilitation unit. There was a dire need to explore stressors of caregivers once the stroke patients were discharged to home because caregiving responsibilities become primary duty for caregivers once the stroke survivors

are discharged to home. Therefore, our study recruited caregivers whose care recipients were living primarily in a home setting.

A study was conducted in Peru to identify stressors and needs of family stroke caregivers (Pesantes et al., 2017). In this qualitative study, 12 caregivers were interviewed, and it was revealed that mental and emotional distress can be due to seeing the pain of a loved one particularly in the initial phase after stroke (Pesantes et al., 2017). Nearly 83% of the caregivers in this study reported experiencing emotional stress due to caregiving (Pesantes et al., 2017). Lutz et al. (2017) in qualitative research studied assessment for preparedness of 40 stroke caregivers to take care of stroke survivors upon discharge to home. Lutz et al. (2017) also found similar results that caregiving for a prolonged period can be exhausting and overwhelming. After stroke patient's discharge to home, being in the patient caregiver role can cause a sense of loneliness and fatigue (Lutz et al., 2017). Prolonged caregiving commitment with no certainty to be able to ever return to normalcy, unforeseen commitment and duration of caregiving is a cause of added emotional strain (Lutz et al., 2017; Moon et al., 2017).

Along with emotional strain, the responsibility of caregiving can in turn impact the social life of a stroke caregiver is identified as a concern by both studies (Lutz et al., 2017; Pesantes et al., 2017). Impact on social life can also be due to time of a caregiver required to look after a patient to prevent patient falls and other unpleasant incidents, which inhibits a family caregiver to leave a patient unattended. Caregivers mentioned that they felt lonesome when caring for stroke victim in a home-based setting (Lutz et al., 2017). Additionally, caregivers reported significant stress of not having sufficient time to engage in other activities, such as going out with family or going out for a walk, which suggests lack of time available to caregivers for any other activities (Pesantes et al., 2017). None of the studies mentioned above highlighted the role

of social support in navigating emotional and social stressors. There was a need to conduct a study in the U.S. to study emotional and social stressors of stroke caregivers and social support resources available to them. Hence, our study addressed this identified gap.

Economic burden associated with informal caregiving is another significant caregiver stressor (American Heart Association AHA, 2018; Menon et al., 2017; Moon 2017; Pesantes et al., 2017). It was highlighted in a quantitative research report by NAC & AARP (2020) that about 38% of the 1,392 sample had less than 50,000 dollars of annual family income. This survey revealed that caregivers were monetarily affected due to tasks of caregiving (NAC & AARP, 2020). It was also identified that caregivers were exposed to experience change in one or more economic aspects, such as compromised future savings or used existing savings, increased debt, borrowed cash, extended work commitment, overdue bills, late bill payments, and moved to low-cost home (NAC & AARP, 2020). Similar results were identified in Lutz et al. (2017) study discussed earlier and non-research special issue on aging by Moon et al. (2017). These articles reported inadequate resources to pay for expenses, such as bills, meals, and prescriptions are also mentioned as concerns for caregivers particularly in stroke caregiving literature (Lutz et al., 2017; Moon 2017). One of the known reasons for lack of funding is the stroke caregiver's inability to work due to time needed for to care for the care recipient (Lutz et al., 2017; Moon 2017). These studies did provide an insight on economic stressors; however, not many studies were found that focused on influence of physical and tangible social support on coping with financial barriers experience by caregivers. Therefore, our study provided an insight on role of social support on all stressors including economic strain.

If a survivor is dependent and has limited mobility, it can add a physical stressor on the caregiver to support the stroke victim in performing normal daily tasks, such as preparing meals

and home chores (Camicia et al., 2019; Llanque et al., 2016; Lutz et al., 2017). Particularly for stroke survivors discharged to the community setting or home, such tasks become the caregiver's responsibility to provide them support (Camicia et al., 2019; Moon, 2017; Sato et al., 2017).

An analysis was conducted on 1442 stroke survivors from 26 hospitals of Japan (Sato et al., 2017). The study aimed to assess level of physical dependence of stroke survivors for discharge to home depending on their number of informal caregivers (Sato et al., 2017). Barthel Index (BI) and Functional Independence Measure (FIM) were used to measure physical dependence of the patients (Sato et al., 2017). The discharge to home from rehabilitation score versus the score of discharge to other settings on BI measure was 65/60 (Sato et al., 2017). These scores were 75/70 in absence of any informal or family caregiver, 65/60 scores in presence of only one informal caregiver, and 60/55 scores in presence of at least two-family caregivers (Sato et al., 2017). On FIM scale, the discharge home score versus discharge to other settings from rehabilitation was 90/89 (Sato et al., 2017). These scores were 101/100 in absence of any informal caregiver, 87/86 scores in presence of only one family caregiver, and 87/86 scores in presence of at least two-family caregivers (Sato et al., 2017). It was found that the cut-off mark of physical dependence for discharge to home was affected by an informal caregiver (Sato et al., 2017). Moreover, it was reported that patients with high dependence were also able to get discharged home in presence of more family caregivers (Sato et al., 2017). However, this study did not explore the viewpoint of caregivers and toll it took on them to perform long-term caregiving role for a physically dependent care recipient. Hence, our study focused on caregivers as primary population of interest.

In the U.S., nearly four million caregivers are helping stroke victims in home setup (National Alliance for Caregiving as cited in Camicia et al., 2019). According to National

Health and Aging Trends data of U.S. on 892 stroke patients and 892 control subjects, interviews of participants revealed that help of their unpaid caregivers is needed by 51.4% of older adults with stroke residing in home or community (Skolarus et al., 2016). Similar results were found in a survey on general caregivers by NAC & AARP (2020) on 1,392 individuals including 70 stroke caregivers, approximately 60% of the total sample were involved in helping with ADLs including toilet transfers and incontinence management (40%), chair/bed transfers (41%), eating (26%), dressing (31%), and bathing/cleanliness (27%). Furthermore, nearly 99% of the caregivers were involved in helping with IADLs including medication management and supervision (50%), cooking (64%), coordination of monetary resources (58%), transportation support (80%), shopping (78%), and daily house-related chores (76%, NAC & AARP, 2020). However, this survey was not focused on stroke caregivers; our study contributed to understand the perspectives of stroke caregivers on physical stressors they have experienced while caring for stroke victims.

Caregiver Coping

Coping is an important matter for caregivers after patient's discharge (Schwertfeger et al., 2020). Schwertfeger et al. (2020) performed a review to study coping measures for stroke patient and caregiver dyads. It was found that nearly 40% of the stroke caregivers face challenges to access coping resources (Schwertfeger et al., 2020). It was also identified that health care professionals emphasized more on medication adherence than community coping measures for post discharge needs (Schwertfeger et al., 2020). Caregivers adopt different mechanisms of coping to deal with the stress of stroke caregiving (Wu et al., 2020; Ye, 2016). There are few broad categories of coping styles: emotion-regulated mechanism (Hawken et al., 2018; Rodriguez-Perez et al., 2017), problem-oriented mechanism (Hawken et al., 2018;

Rodriguez-Perez et al., 2017), and meaning-oriented mechanism (Hawken et al., 2018; Rodriguez-Perez et al., 2017; Schoenmakers, et.al., 2015).

Emotion-regulated mechanisms involve management of behavior and change in attitude towards stressful stimulus (Rodriguez-Perez et al., 2017; Schoenmakers et al., 2015; Ye, 2016; Zur, 2017). This mechanism can include coping with stroke-induced circumstances by responding to them with a positive approach, accepting the situation, gaining strength from religious activities (Pesantes, 2017; Ye, 2016) and yoga (Ye, 2016).

Avoidance is another type of coping mechanism (Rodriguez-Perez et al., 2017; Ye, 2016), which is a subtype emotional-regulated coping style (Ye, 2016). Avoidance coping style involves desensitizing or detaching oneself from source of problem (Rodriguez-Perez et al., 2017; Ye, 2016). This may include taking some relief from continuous caregiving duties and to be able to rejuvenate oneself by doing activities for self-care or self-help (Pesantes, 2017; Ye, 2016), relaxation/outing (Ye, 2016), using humor (Pesantes, 2017), doing non-caregiving tasks (Pesantes, 2017; Ye, 2016).

Problem-oriented coping involves active skills of eradicating the cause of stress or crisis (Rodriguez-Perez et al., 2017; Schoenmakers et al., 2015; Ye, 2016). Problem-oriented coping include seeking solutions for stressful issues, such as active coping skills to deal with caregiving stress (Hawkins, 2018), planning and coordinating care (Hawkins, 2018; Ye, 2016), and reprioritizing work list (Ye, 2016). Such strategies help in solving caregiving problems, and they are counted as problem-oriented coping mechanism.

Meaning-oriented coping style involves strategies that reiterate values and philosophical beliefs to facilitate adaptive response to a stressor (Schoenmakers et al., 2015). For example, it

involves relating the caregiving role to a higher purpose and finding personal value in caregiving.

Social support-oriented coping is also among the types of coping mechanisms identified in the caregiving literature (Rodriguez-Perez et al., 2017; Schwertfeger et al., 2020; Ye, 2016). Social-support oriented mechanisms are ways to find social sustenance that aids to prevent loneliness (American Psychological Association (APA), 2021) and emotionally cope with caregiving problems by providing a source of outlet (APA), 2021; Rodriguez-Perez et al., 2017, Ye, 2016). Social ties help to enhance self-confidence and self-sufficiency that makes an individual competent to solve issues (APA, 2021). Similarly, a qualitative study revealed that the presence of a social network to share caregiving tasks enhances emotional health and sense of autonomy of stroke caregivers (Pesantes, 2017).

There are a few studies conducted on caregivers regarding utilization of the above-mentioned coping mechanisms. Rodriguez-Perez et al. (2017) conducted a cross-sectional study on a large sample of 86 caregivers of dependent older adults. The purpose of the study was to determine the association between quality of life (QOL) and coping measures used by family caregivers (Rodriguez-Perez et al., 2017). Poor coping was linked with reduced mental aspect of QOL (Rodriguez-Perez et al., 2017). Better environmental and mental aspects of QOL were found to be linked to social-support oriented coping mechanism and emotion-regulated mechanism of coping (Rodriguez-Perez et al., 2017).

Ye (2016) conducted mixed methodology study of a secondary data analysis that collected data on time points of three months, six months, nine months, one year, and five to seven years to examine stressors and coping measures of stroke caregivers over span of five to seven years' time. Thirty caregivers were enrolled, and it was identified that caregivers

experienced moderate level of stress with time span that ranged between 12.8 and 15.7 on Perceived Stress Scale (PSS; Ye, 2016). It was also reported that caregivers coping scores ranged between 104.4 and 119.9 on Family Crisis Oriented Personal Evaluation Scale (COPEs; Ye, 2016). There was a significant relationship ($p = 0.01$) between lower PSS scores and high COPEs scores (Ye, 2016). The relation between higher coping and lower stress was not affected by time (Ye, 2016). The sub-scale measures on family network support ($p = 0.03$) and social support measures ($p = 0.02$) were found to decline with time (Ye, 2016). It was found that maintaining social support declined with time for stroke caregivers (Ye, 2016). Active problem-solving coping strategies were found to be common in initial years of stroke care continuum (Ye, 2016). Emotional-regulated mechanisms and encouragement from religious activities were found to be a means of coping for caregivers over the course of stroke recovery (Ye, 2016). Conclusions from the qualitative aspect of this study mentioned that taking break or respite and having positive outlook helped to cope from strains (Ye, 2016).

Wu et al. (2020) conducted a quantitative study on a large sample of 242 informal stroke caregivers using non-probability convenience sample. Stress was found to be associated with monetary strain ($p < 0.01$; Wu et al., 2020). Caregivers experienced stress due to causes, such as survivor's institutionalization, physical dependency, monetary strain (Wu et al., 2020), increased care needs, and an unpredictable future (Ye, 2016). They coped with these stressors by seeking emotional and instrumental help, thereby gaining knowledge, and learning skills required to care for stroke victims (Wu et al., 2020).

Similar conclusions were drawn from a review of 53 articles on stroke patient-caregiver dyad coping. It was revealed that mechanisms of coping mechanisms included rationalization, availing the support network (Ramazanu et al., 2020). It also mentioned about other coping

strategies, such as managing emotions towards stressors, active problem solving, and avoidance style or absconding from caregiving tasks (Buschenfeld et al., as cited in Ramazanu et al., 2020). Not many studies were conducted on coping mechanisms of stroke caregivers and strategies they adopt in different phases of stroke care trajectory. Our study helped to understand different coping mechanisms adopted by stroke caregivers in different phases of stroke caregiving. Caregivers in our study ranged from being in acute initial phase of caregiving to having decade(s) of caregiving experience.

Social Support and Caregiving Outcomes

Social support is an essential concept in Pearlin's Stress Theory (Pearlin et al., 1990). It serves as a mediator for appraisal of caregiving stress, thereby it can influence caregiver outcomes (Pearlin et al., 1990). It is important for caregivers to utilize their support system to adaptively cope with stress (John Hopkins, 2021; Pearlin et al., 1990). Social support can be available to an individual in the form of formal (professional) or informal systems that includes family, friends, or communal groups (John Hopkins, 2021; Shiba et al., 2016).

There are four essential types of social support: Instrumental, Emotional, Appraisal, and Informational (John Hopkins, 2021; University of Pennsylvania, n.d.). Instrumental or physical social support includes help with errands (John Hopkins, 2021), support in performing other roles (University of Pennsylvania, n.d.), and assistance with transportation (John Hopkins, 2021). Another form of social support can be in the form of psycho-emotional facilitation that provides compassion and empathy to the recipient of support (John Hopkins, 2021; University of Pennsylvania, n.d.). Appraisal is another form of social support that helps to obtain a positive outlook of a self or situation (John Hopkins, 2021; University of Pennsylvania, n.d.).

Informational social support is in the form of resources, recommendations, and information (John Hopkins, 2021; University of Pennsylvania, n.d.).

Social Support and Caregiving Outcomes: Burden and Depression

Lutz et al., (2017) identified the support system as a significant matter affecting capacity of a caregiver to look after a stroke survivor. Social support is linked with loneliness (Woodford et al., 2018) and caregiver strain or outcomes, such as anxiety, depression, health outcomes, etc. (Akosile et al., 2018; Pearlin 1990; Pino-Casado et al., 2018; Tosun & Temel, 2017; Wang et al., 2016; Yang et al., 2019). Social support can serve as an intermediary variable between self-efficacy and the variables of quality of life of patients and caregivers' strain (Leung et al., 2020). Through self-efficacy, social support from family can indirectly decrease caregivers' burden and increase quality of life of patients (Leung et al., 2020).

A quantitative study was conducted on caregivers of Parkinson' disease on social support as mediating variable on caregiver strain (Yang et al., 2019). Regarding the impact of patient physical activity level on caregiver strain score in the model, self-efficacy and social support justified variance of 0.768 (Yang et al., 2019). However, this study was not conducted on stroke caregivers, and this study had limited sample size (Yang et al., 2019). This called for an in-depth study on stroke caregivers having wide range of years of caregiving experience to explore the role of social support as mediating concept for caregiver stress and burden.

In a study on stroke caregivers, perceived social support mean score using the Multidimensional Scale of Perceived Social Support (MSPSS) was 60.2 on a scale from 12 to 84 scores with standard deviation (SD) of +/- 17.0 (Akosile et al., 2018). Family subscale of perceived social support scale was known to be inversely linked ($r = -0.295$) with stroke caregiver strain (Akosile et al., 2018).

Likewise, a study conducted on 2998 caregivers revealed that informal social support was found to be substantially related with decreasing caregiver strain ($p < 0.0001$), whereas formal social support was not found to have a significant correlation with caregiver burden (Shiba et al., 2016). Burden on caregivers was lessened by the presence of one ($p < 0.0001$) or more ($p < 0.0001$) informal supports (Shiba et al., 2016).

Similarly, a meta-analysis of 56 studies mentioned that there was an inverse relation between caregiver strain and perceived social support ($r = -0.36$), and there was an inverse relation between caregiver strain and received social network support ($r = -0.05$; Pino-Casado et al., 2018). Another study showed similar findings on 66 survivors of stroke and their families found that the relation between total perceived social support of stroke informal caregivers and their burden inventory was moderate (-0.512) with statistical significance of $p < 0.000$ (Tosun & Temel, 2017). Particularly in the first six months, stroke caregiver strain was an identified challenge (Han et al., 2017); it was proposed in this study on 328 subjects of stroke patients and their caregivers that nearly 46.8% to 55.0% of variance in caregiver strain was contributed by different factors including caregiver depression, survivor's dependency, and social support ($p < 0.05$, Han et al., 2017). These studies suggest that interventions can be planned by health professionals to enhance family or informal social support to reduce strain on stroke caregivers in a home environment (Akosile et al., 2018; Han et al., 2017).

Along with influence on caregiver burden, adequate social support is known to impact physical (John Hopkins, 2021) and mental health of caregivers (John Hopkins, 2021; Shiba et al., 2016). Social network is known to affect caregiver outcomes and depression scores (Wang et al., 2016; Yang et al., 2019). Self-efficacy and social network or social support served as moderating concepts in the model, whereby impact of patient functionality on caregiver

depression contributed to the variance of 0.510 (Yang et al., 2019). Similarly, another study on 567 informal caregivers of older adults supported the stance that higher social support on MSPSS can decrease caregiver depression on Center for Epidemiological Studies Depression measure (CES-D) as mediated by strain on Zarit Burden Inventory of caregiving (ZBI) with a total effect of $p < 0.001$ (Zhong et al., 2020). A study on stroke caregiving revealed that caregiver measure of unpredictability was linked with their depression ($p = 0.001$, Byun et al., 2016). Moreover, caregiver unpredictability measure was affected by social support as one of the important variables (Byun et al., 2016). Despite the recognized value of social support in caregiving literature, it was hard and challenging for caregivers to use social support in community (Ye, 2016). Additionally, as compared to baseline, the availability of social support diminished over time in the stroke trajectory of caregiving (Byun et al., 2016). Therefore, our study can contribute to enhanced understanding of need of informal social support and its role in shaping experiences of stroke caregivers. In-depth qualitative perspective can help to understand how time and situation affect the social support available to stroke caregivers.

Summary

According to existing literature, caregiver stress is an identified issue for the caregiver population. Caregivers adopt different mechanisms to cope with their strains. The role of social support appears to be promising to curtail the burden of caregiving and improve caregiver outcomes, such as depression and anxiety (Pearlin et al., 1990). However, there were not many studies that explored the role of informal social support particularly on the experiences of stroke caregiver population.

Gap in Literature

In-depth analysis of literature revealed that there are not enough studies specifically on informal social support (family, friends, relatives, neighbors, etc.) available to stroke caregivers. Real challenges of stroke caregiving are burgeoning matter for caregivers after discharge when a stroke victim is solely the responsibility of a caregiver; therefore, the role of informal social support is important to be studied at that time.

Pearlin Stress theory was initially developed for Alzheimer's caregivers (Pearlin et al., 1990). Pearlin's theory was used on caregivers of people with chronic conditions including stroke caregivers by Lee (2015). This study assisted to assess application of the construct of mediators from Pearlin's Stress Theory on stroke caregivers using qualitative approach.

Availability of social support and nature of informal social support accessible to caregivers can influence their long-term outcomes; hence, it was significant to study the dynamics of their informal social support.

Caregivers are often unidentified or invisible patients. Because of their caregiving role, societal health paradigm does not provide them direct access to facilities except when they come into the system as primary patients. It was essential to unveil their challenges and resources that can influence the well-being of caregivers. Nurses can play a significant role in identification of this issue to advocate for this population. Therefore, the purpose of this study was to explore the role of caregiver in care continuum and identify the impact of informal social support on experiences of stroke caregivers in consideration of Pearlin's Stress Theory.

Family caregiving is an invisible phenomenon because caregivers are often not in the first-hand contact with health services for their own problems. They approach health network for the needs of primary stroke care recipient; thus, their own needs may not be observed and attended

as a matter of prime important. This calls for resources, such as educational sessions, support groups, skills enhancement campaigns, etc. to be available in community setting that can be used by any caregiver who might need help and support at any point in caregiving trajectory regardless of if they are in contact or not with any health system.

CHAPTER THREE

Methodology, Study Design, and Procedures

Introduction

The role of informal social support is an important asset to be studied for the stroke caregiver population. Application of Pearlin Stress Theory can serve this purpose; however, not many studies have applied this theory for stroke caregiving. The purpose of this research was to identify stroke caregiver expectations and analyze the role of social support in the framework of Pearlin Stress Theory. To achieve this purpose, the details of study design, study setting, sampling methodology, screening criteria, procedure of data collection and analysis, ethical measures, and study rigor are elaborated in this chapter.

Study Design and Method

The design for this study was qualitative phenomenological. Descriptive design aids to obtain pertinent data in the best interest of available resources, whereby the informants who have first-hand experience of the topic of interest provides the description of the phenomenon (Bradshaw et al., 2017). In this study, description of the experiences of stroke caregivers related to availability of informal social support was explored. The circumstances and situation of stroke caregivers was taken into consideration. Qualitative phenomenological design is an appropriate design for this study that helped in the investigation of experienced topic related to the health problem.

Study Setting, Recruitment, Procedure, Data Collection Method

Institutional Review Board (IRB) approval was acquired prior to data collection. For having a heterogenous sample, the data was collected from informal caregivers of stroke victims from diverse support groups.

Permission letters from all the selected sites where caregivers were approached were obtained prior to data collection. For this purpose, informal caregivers of stroke victims were approached using an invitation script (Refer Appendix A) by the investigator using word-of-mouth, emails, direct approach, flyer (Refer Appendix B), and presenting this research study in sessions, support groups, activities, and opportunities provided by the recruitment sites. The leadership or organizers of these support groups took the responsibility to email the flyer to the participants of their support groups.

Potential participants were screened using a screening script (Refer Appendix C) to help respondents understand the research purpose and study process. This call also helped to identify suitable respondents who meet the determined eligibility criteria. After consensus of participants, the organizers of virtual support groups helped the researcher to connect with interested participants by exchanging phone numbers. Some of the interested participants approached the researcher on her phone number given on the flyer, whereas some interested participants were called by the researcher. Eligible respondents were asked about their feasible day and time for data collection on this call.

A flyer was developed to improve enrollment. This flyer has basic information about the study. The flyer was given by the investigator in soft electronic copy to the organizers, leaders, and administrators of the sites of recruitment. These leaders circulated flyers and/or post them on their sites where it is clearly noticeable for the population of interest.

Sampling

The researchers utilized purposive sampling to recruit participants. Purposive sampling assists to enroll relevant respondents who can provide in-depth details regarding the identified research problem (Palinkas et al., 2015). Purposive sampling is not a random sampling method

which helps to deliberately enroll respondents who have specific experiences that can help to better understand the study phenomenon, thereby they are able to best respond to the question under study (Johnson et al., 2020). Therefore, this sampling method was suitable to recruit respondents who can provide insight on the topic of interest. Informal stroke caregivers were purposefully recruited to unveil the role of social support of informal caregiving.

Upon reaching data saturation, sample size for this study was identified. Since data collection and analysis is performed simultaneously in a qualitative research design, it is possible to determine data saturation (Johnson et al., 2020). Data saturation is the point, whereby novel data or patterns are not evolving and only redundant themes are found (Johnson et al., 2020). It was anticipated that between 8 and 20 respondents will be interviewed for this research.

Screening Criteria

The screening criteria for participants of this study is as follows:

Inclusion Criteria.

- The participant must be at least 18 years old.
- The participant must consent voluntarily to partake in the study.
- The respondent must be able to talk in English.
- The respondent must have (current or past) stroke caregiver experience. This is irrespective of the living status of the stroke victim.

Exclusion Criteria.

- Paid professional caregivers were not included in this research.

Interview appointment was set up collaboratively according to the feasibility and availability of the respondents.

Data Collection

On the day of data collection, verbal consent was obtained from the respondents on the telephone (Refer Appendix D the Script of Verbal Consent). For the IRB, each respondent was assigned a numeric code since the researcher called the respondents using their names and phone numbers. After consent, audio recorder was turned on and demographic tool (Refer Appendix E Demographic Tool) was completed on phone prior to the beginning of the interview. Collecting basic demographic details facilitated the researcher to understand the background of the respondents. The identified demographic details were relevant to caregiving, such as number of people in household, caregiver gender, relationship with stroke victim etc. (See Appendix E for all demographic questions).

Semi-structured interviews were conducted on telephone (Refer Appendix E Interview Guide). Semi-structured interviews are used commonly in health research (Jamshed, 2014); it entails predetermined broad questions and includes probes that guide the interview process to divulge rich responses from interviewees (Jamshed, 2014). Probes helped to seek clarification and facilitate responses. A semi-structured guide provided structure and gave talking points in the interview; however, it allowed room for flexibility and modification for an open-ended inquiry. Therefore, interviewing was an appropriate method of data collection method for this phenomenological study.

According to the collaborative data set, the respondents were called on the phone. Interviews were done on the phone and were recorded using audio recorder. The interviewees consented to be audio recorded. Recordings were kept secure on the university OneDrive. The folder on OneDrive was shared with the Dissertation Chair,

whereby the recordings were only accessed by the principal investigator and faculty advisor. Approximately 30 to 90 minutes were estimated to be required to conduct one interview. Relevant questions and probes on stress, coping, and social support were asked to explore more detailed experiences (Refer Appendix E). To sign off with respondents, an opportunity was given to them to share any additional comments and experiences they may have. At the end of the interview, all participants were provided the resource link <https://www.stroke.org/en/help-and-support/for-family-caregivers>. The information on this link can be beneficial for the caregivers as it has relevant information regarding stroke and the needed care.

After interview, address of each respondent was taken to mail gift a \$10 gift card as a gesture of appreciation for their participation card. Participant addresses were not part of data collection and were just taken to send gift cards. Gift cards were sent using registered mail to ensure that respondents have received the gift cards.

Data Analysis

The demographic information was analyzed manually in the form of aggregated data using basic descriptive analysis. Mean of age of respondents, central tendency of time elapsed since stroke, and mean number of people in household were calculated. Frequency and percentages of the remaining variables were tabulated that includes sex, ethnicity/race, marital status, relationship with stroke victim, education level, and cohabitation status. Work status and services patient receiving/received were also covered. The demographic information was secured in the shared OneDrive.

To maintain an audit trail, a process log was maintained (Refer Appendix F Process Log). After data collection, the data from audio recordings was transcribed in a word

document. The transcription was done by a renowned transcription agency, which is associated with the PROMIS lab at UTA. They are reputed in the business of transcription and have been serving the research community by providing transcription services. They ensured that the recordings were kept secured, and they took all ethical measures to protect the data. The recordings were shared with the transcription agency using OneDrive. After transcription, the audio recordings were not kept, and they were erased.

Using the inductive method, the transcription material was read repeatedly by the researcher at least three to four times, and important codes were recognized manually. Every new thought or concept was labelled as a new code representing the identified idea on the margin of transcribed word document. A code book was maintained, whereby codes from each participant was assigned a specific color code. There were more codes from first few participants; as the researcher conducted more interviews, fewer new codes and themes emerged. This color code book helped the research to predict data saturation. The material was analyzed and categorized in important themes (Polit & Beck, 2017). Patterns from data were observed, and similar codes were labeled in broader themes

There were assumptions in data analysis. It was assumed that informal caregivers were engaged/have been engaged in caregiving responsibilities and considered caregiving as an essential task. It was also assumed that the researcher will discover some informal social support during the interview. It was also assumed that there will be some common points of agreement and patterns between the informants.

Benefits and Risks

There was no initial benefit for respondents to be in this research. However, a respondent may reduce stress after being allowed to verbalize their needs to someone. The interview session could help them reflect and express their issues. The results of this study could be beneficial for the general caregiver population at home to help plan resources for this group.

As part of this study, the respondents were not anticipated to undergo any physical, social, or legal harm. The participation in this research might have only caused typical routine discomfort to the respondents, such as some stress because of the time spent talking to researchers as well as remembering negative caregiving encounters. To mitigate some of the discomforts, caregivers received a resource website link with information that they may want to know about being a stroke caregiver. The respondents were not obliged to reply to all the questions if they were uneasy to do so. If any interviewee felt unhappy while sharing any unlikable experience regarding caregiving, he/she were offered time to recollect. And if needed, the interview was postponed or stopped.

Ethical Measures

Ethics in research ensures right standards utilized in the study course (Johnson et al., 2020). To meet ethical standards, approval from the IRB was received before any data collection. For the IRB review, a letter of consent from the different organizations was obtained to allow the principal investigator to approach their population for recruitment. Some of the measures to safeguard ethical aspects of the study included gaining informed consent and ensuring that respondents did not have to answer anything that was

uncomfortable or caused them uneasiness. Additionally, they were reassured that it is voluntary, and they can stop at any time if they wish to do so. There was no loss of any services if they choose to stop volunteering to be a respondent in the research. These steps ensured that the autonomy of respondents was respected.

Other measures of ethical safety included protecting data transcription and copy of recordings in a password locked device in a secure OneDrive. Further, the principal investigator destroyed recordings once the material was transcribed, and the research will ensure protecting respondents' identity if the research is made available for publication by using assigned numeric codes to the respondents. Such measures help to guard the privacy and confidentiality of the respondents and made them comfortable to partake in the study.

Rigor

Lincoln and Guba (1985) presented dependability, credibility, confirmability, and transferability as the four key standards of research trustworthiness (Polit & Beck, 2017). According to Lincoln and Guba's standards, credibility is the reliance and trust in findings (Polit & Beck, 2017). In this study, credibility was achieved by in-depth interviews which allowed adequate time for the researcher to inquire about the lived experiences from the stroke caregivers.

Confirmability is defined as the neutrality and accuracy of the results between more than one individual to ensure adherence to accurate study outcomes obtained from the information by respondents (Polit & Beck, 2017). To achieve confirmability, qualitative data analysis expert from UTA reviewed some of the transcripts during the analysis process to help ensure that the themes and codes identified by the principal investigator

are the true reflection of interviewees' responses. The expert analyzed the selected transcripts and matched it with analysis of the principal investigator to ensure that the findings are not impacted by biases or subjectivity of the researcher. Having personal notes also helped to maintain the confirmability aspect of the study, thereby upholding those personal assumptions did not affect the true outcomes.

Dependability is another standard of Lincoln and Guba's framework (Polit & Beck, 2017). Upon replication of the study procedure, dependability is the ability to get consistent study results (Polit & Beck, 2017). Without dependability, accomplishing credibility in a qualitative research study is not possible (Polit & Beck, 2017). To attain dependability, the investigator has provided replicable study procedure in this chapter (Refer heading Methodology, Study Design, and Procedure).

Transferability describes the implication of study outcomes on similar situations and/or population (Polit & Beck, 2017). The findings that are identified from this research is expected to be related to the caregivers of patients with cognitive and physical issues and particularly for stroke caregivers, thereby assuring the transferability of this research. For example, the results of this study may be applicable to caregivers caring for other acquired brain injuries.

Another standard of rigor is reflexivity which prevents contamination of study results by subjectivity and presumptions of the investigator (Johnson et al., 2020). It confirms the fairness and accuracy of study procedures (Korstjens & Moser, 2018). To ensure reflexivity, the investigator kept a note of personal postulations and prejudices to maintain the truthfulness of the results. For example, the researcher may have biases about caregiving expectations due to differences in cultural and ethnic background.

These notes were maintained throughout the data collection period to capture any potential biases. Keeping a track of notes helped to mitigate potential for contamination of study results. It assisted the researcher to stay true and objective to the study findings. Throughout the research process from flyer distribution to consent to data collection, a log of researcher's thoughts and ideas was maintained to ensure researcher's personal biases and understanding did not impact study results.

Delimitations

This research had a few limitations that are stated below:

- 1- The experiences of non-English-speaking caregivers were not captured in this study.
- 2- Respondents were only recruited from the identified sites.

Summary

To conclude, phenomenology qualitative design was applied in this research. Purposive sampling was implied to recruit participants who have insight on the study topic. Study procedure was followed for eligible respondents. Thorough data analysis procedure was followed to protect essential points of transcribed data. Ethical measures were in place to respect rights and privileges of the respondents. Quality and study rigor was preserved to shield the authenticity of conclusions.

CHAPTER FOUR

Study Results

Chapter four contains study results. Table 1 elaborates demographic characteristics of the study participants. Study themes and codes derived from study participant narratives are explained and supported.

Data saturation was achieved after the interviews of ten stroke caregivers. No new themes were identified in the last two transcripts. The interviews were conducted via recorded phone interviews. The researcher tried to recruit participants with diverse characteristics. Half of the respondents were men, and half were women. Regardless of attempts to recruit diverse participants, all the subjects were White or Caucasians. The description of demographic details is given below:

Table 1- Demographic Characteristics

Characteristics	Values
Age (mean years)	72.8 years (n=10)
Time/ years elapsed since stroke (measures of central tendency)	6 years (mean) 5 years (median) 2 years and 9 years (modes)
Mean number of people in household of caregiver Note: Incase stroke victim is not alive, mean here represents the number of people at the time when stroke victim was alive.	2.1 (mean for n= 10)
Sex (frequency, percentage)	Male= 5 (50%) Female= 5 (50%)

Race (frequency, percentage)	White/Caucasian= 10 (100%)
Marital status (frequency, percentage)	Single= (1, 10%) Married= (8, 80%) Widower= (1, 10%)
Relationship with Stroke Victim (frequency, percentage)	Fiancé= (1, 10%) Husband= (4, 40%) Wife= (3, 30%) Mother= (1, 10%) Sister-in-law= (1, 10%)
Education Level (frequency, percentage)	Less than college = (4, 40%) College graduate = (2, 20%) Skills training= (1, 10%) Undergraduate= (0, 0%) Professional degree or Graduate level or above= (3, 30%)
Living with care recipient (frequency, percentage) Note: In case stroke victim is not alive, here it represents the status when stroke victim was alive.	Yes= 8 (80%) No= 2 (20%)

Work/Job

Five (50%) of the subjects were not working. Four (40%) reported working outside the home during the time that they were caregiving. One of the subjects was still working part-time while caring for the stroke survivor.

Services Stroke Victim Receiving/Received

The services in use/used by stroke victims in their stroke continuum was diverse. Hired help and/or home health was used by some. Inpatient therapy and outpatient therapy services were also commonly used. Day-Neuro that is an outpatient service to improve affected skills of stroke survivors were also among facility used by participant(s). Nursing home, personal trainer, rehabilitation services, and inpatient hospitalization were also listed among services receiving/received by the stroke victims. Some of the therapies and/or other services mentioned above were covered by insurance to some extent.

Table 2- Themes and Sub-Themes

Themes	Sub-Themes
Work Life Balance	-
Reaction of Other People or Family to Stroke	-
Themes	Sub-Themes
Expectations and Responsibilities from Caregivers	<ul style="list-style-type: none"> • ADLs/IADLs, • Home Modification, • Care Management, • Constant Vigilance, • Impact of Gender Roles

Impact of Stroke on Abilities of Victim	-
Stressors and Concerns for the Caregivers	-
Strategies Used by Caregivers to Cope with Stress	-
Social Support to Stroke Caregiver and Care Recipient	<ul style="list-style-type: none"> • Consistency and Adequacy of Social Support, • Role of Paid Services, • Emotional Support and Appraisal, • Availability of Informational Social Support, • Role of Support group and Other Services.
Respite or Self-Care for Caregivers	-

Themes

Work Life Balance

Work Life Balance is a theme identified in the study results. It explains the need of informal stroke caregivers to be able to manage other roles and responsibilities along with the role of caregiving. The nature of work and support system at work also specifies a caregiver's ability to be able to strike balance between work and caregiving responsibilities. Participants

said that: "I was employed. Yes. Worked from home so I could take care of, now, fortunately, I had a job where I worked at home all along". (P.2)

My manager is a really nice guy. I usually go in in the mornings or, you know, for a few hours during closing. He understands if, you know, if anything were to happen, I can just, they gave me the go-ahead to go ahead and leave, and they'll call somebody for me if I need to. At least I'm grateful for that, because not a lot of employers usually allow that. (P.9)

And so my role would be to go directly to her home when I finished work at 4:00, 5:00 and basically just keep her company and do anything that the caregiver needed, like a leaky faucet, the machine doesn't work, the television doesn't work, things like that. (P.1)

It was also found that inability to manage multiple responsibilities could result in quitting work responsibilities. A study subject mentioned that:

I can't work. I have to stick pretty close.... I was working when the stroke occurred... And at that time, it just all got to be too much. Something had to go and the job went... before I worked, and I worked as long and as many hours as I wanted to. (P.10)

Reaction of Other People or Family to Stroke

This theme helps to understand that people around may not be prepared or willing to respond to stroke victims. It could be due to lack of awareness and knowledge of dealing with handicap or incapacitated individual. It may also be due to fear of liability or responsibility in case any incident happens when someone is with a stroke victim. Hence, people may not want to socialize much with stroke victim and/or caregiver, which could impact their social lives.

You know, nobody wants to come over and take him out somewhere, because you lose your friends like that, so... I think that the people don't understand, they don't know how to deal with the stroke patient. You know, most people, especially men, don't have the patience to be involved with a stroke person. But, you know, (*stroke victim) can talk, and he can carry on a conversation most the time with people. You know, but I think that most the people, I see it as maybe they're afraid of a stroke patient. Oh, you know, golly, I don't want to be with them. You know, maybe, what if they fall? What would I do? Would I get blamed, you know, or something like that.

You know, and I've caught myself not wanting to take somebody that was handicapped lady. You know, I guess they don't want to be responsible for somebody else. I think that's it, you know. Maybe they don't, now, we did used to go with a couple for lunch every week. Once a week, we would go with them for, you know, to lunch, but, and we

would just sit there and talk, maybe some type of talk and stuff. But there again, you know, I don't think that the other men have tolerance, not with just the men or man, but I don't think they would have talks with a handicap person. They don't know what to do, how to handle it . . . that's my, that's just my assessment. (P.6)

Expectations and Responsibilities from Caregivers

This broad theme takes into consideration roles and tasks implied to be performed by a stroke caregiver. The sub-themes under this theme include ADLs/IADLs, Home Modification, Care Management, Constant Vigilance, and Impact of Gender Roles.

ADLs/IADLs

One of the most highlighted responsibilities from stroke caregivers was to assist the stroke victims in providing them personal care and instrumental care for their functioning. This includes transfers, moving, shopping, driving, cleaning, cooking, and dressing. Getting these tasks assigned to them without being prepared for sudden stroke event can be a source of shock for the caregiver(s). Respondents mentioned that:

I could go over in the morning before lunch. I could go in the evening at 6:00 p.m. and, '16, 2016 to 2020, over that four-year period, then the capability of the (paid) caregiver started to decline, and so I would be asked to help with (*stroke victim name) physically, like take her from her chair and transition her into the wheelchair, help transition from the wheelchair to the bed, help transition her from the bed out into the wheelchair, and from the wheelchair back into the chair that she had spent most of her time in, like a reclining chair. (P.1)

The first year, yes. I had to do everything. She was wheelchair bound. I had to dress her and shower and help her in and out of the bed, help her in and out of going to the bathroom. I could, I would wheel her wheelchair in there and I had to stand her up, sit her on the toilet. She could do her business and clean, and then I had to help her stand up and sit her back in the wheelchair. (P.2)

It's all me. And that was a major shock to me, . . . because prior to her stroke, we had the, what I thought was a conventional situation where she took care of all the house and the housework and so forth, and I took care of everything else. So, when she had her stroke, I was thrown into doing things that I knew absolutely nothing about, and that was a major, major shock for me. (P.3)

I've had to be the, almost the sole contact with the outside world in that she's not able to interact, and so I have to be the, oh, I guess, messenger or the interface. Like shopping for groceries, like shopping for clothes that she might, would like to have, new shoes that she would like to have, those aspects. That's about, I've just, I've become her representative, I guess, to the world. (P.3)

I do take him to rehab and take him to his 15 doctors, I think. So I have to drive him. He doesn't drive. I have to drive him every place. Let's see what else. You know, I have to empty diaper pails, which I had never done since my children were little. Yeah. Constant cleaning up. (P.5A)

Well, I don't think she does very much. She just exists on her own, you know. I take care of dressing her. And she, also, the other thing she has is incontinence, and so I have to help her with bathroom visits and changing her special underwear that she wears. But she really doesn't do anything other than just sit and watch tennis on TV, and she can feed herself. You know, I make all the meals and put them on the table and provide her kind of snacks and drinks when necessary. (P.7)

Home Modification

Performing repairs at home and modifying home to make it user-friendly for a stroke survivor was also identified as a significant sub-theme. Before taking a stroke survivor home, caregiver had to make sure about safety measures at home. One of the respondents said:

I studied what she was capable of doing while she was in rehab, and I studied what, where the bars and so forth were in the bathrooms, and how they moved her around. So, I then had all that ready to go at the house before she came home.

I knew precisely what she was going to need. I knew exactly what it was going to take to get her into the shower. I put the bars exactly where they needed to be. I even rehearsed it with my own body, intentionally impairing my right side and imagining what, where she had to put her hands and when to get in and out of the shower and in and out of the bathroom. (P.10)

And I came in with a piece of paper. I had sketched out what our walk-in shower looked at, had measurements on it. So, I'd say here's the width of the door and the depth in the shower. And I had all the measurements, and there was a step into it, I had it all written out for them. So, they were kind of like, wow, it's all spelled out what we need. I mean, I just, I think it's, you know, being a computer programmer, the way my brain analyzes things to figure stuff out, I'm always, was just constantly, anytime we'd be out walking or something, I'd be walking with her holding her, but I'd be looking five steps ahead, make sure there wasn't a little bump in the sidewalk or a little rocks she might step on and lose her balance.

I was just constantly thinking ahead, and that's just the way my brain works. I didn't have to really go out and learn anything. I mean, I just figured these things out, and I said, you know, this is the most logical way to do this, so this is what we're going to do. (P.2)

Care Management

Coordinating care and doctor appointments is another responsibility assumed by care partners. This includes arranging for appointment, driving to appointments, tracking health status, and health-related decision making. A study participant said:

I have to make the appointments. I have to make sure that we get there when we do go. I have to keep current and keep accurate records of the medications that she's on, and when she takes them, and what the dosage is. And if the dosage varies, I have to keep track of that, accurate track of it.

As an example, she takes Warfarin as a blood thinner, and we have to check her INR measure weekly and then adjust the dosage of Warfarin up or down to keep her INR measure within limits. So, yeah, and then when we go to the doctor's, if a doctor asks her how she feels or if she hurts, or where she hurts, or what kind of hurt she has and so forth, I have to try to, as best I can, determine that from her and then give, tell the doctor about it.

She's not able to directly address that. I have to make virtually all decisions for her. She has a very difficult time in choosing one thing or the other, or God forbid, one out of several, that type thing. (P.3)

When he was in physical therapy, I drove him to his appointments and helped him get through the process of being signed in and everything, getting his medications, just generally just trying to get him out of the house. (P.9)

Constant Vigilance

Ongoing guarding and vigilance is a notion mentioned by a few participants. Fear of any unpleasant incident upon leaving a stroke survivor unattended was their source of concern that inclines them to continuously monitor care recipient. This was found to be tiring for caregivers and could be a means of isolation for stroke victims and their caregivers.

So it's just being, you know, from the moment she got up, you know, 5:30, 6:00 in the morning until she went to bed, which is usually about 9:00 or 9:30, I was on constant guard, you know, kind of like watching a very small child. You just can't take your eyes off of him for a minute. So it was pretty taxing, I guess you could say. (P.2)

So, but I, and, of course, it limited any kind of outside activities that I had been involved in. I would oftentimes spend a lot of time working out in the garage doing things. That kind of went away because I couldn't afford to be outside when she was in here by herself.

And, of course, if I had to go somewhere, that was after she came home, if I had to go somewhere, you know, I had to make sure that she had some way to contact me or something, and I could only be gone for a very short time. (P.3)

It's isolated me as well, because in her particular condition, I have to be here almost all the time. Because I don't know, well, I'm aware that since she has had one stroke, that there's a potential, a better potential for another stroke to occur, and so I have to be aware of that. And, frankly, I'm very cautious about leaving her by herself for any, you know, period of time. (P. 3)

Well, it's affected how I spend my time. I have to focus on making sure that she's okay and safe, you know. She did have a few falls originally, after the first stroke, but now I make sure that she's safe and doesn't kind of get out of her wheelchair without some kind of supervision.

And it's affected, we don't go anywhere, and we don't go out to eat at all. We used to do that occasionally. And we don't make trips anymore, so we basically are housebound most of the time. (P. 7)

Impact of Gender Roles

The aspect of conventional or gender roles and responsibilities also play part in allocation of duties to care partners. The allocation of errands based on gender was impacted due to the event of stroke. In traditional gender roles, home-related tasks are implied to be carried by women. Whereas tasks requiring physical or technical labor are mostly considered suitable for men.

I wasn't taking care of the yard. And I did cook, but, you know, I didn't take care of the car. I don't know what else I did. I did, you know, what most housewives do, but now I'm doing what most housewives and husbands do. (5A)

Well, I think the difference I'm aware of is before the stroke, if there were things I needed to do outside the house, you know, like go to the banks or investment firms or things like that, and hardware stores, I would take the time it took. And I would also do a fair amount of gardening and yardwork. So I spent a lot more time out of the house, working on stuff that I'm the best person to do, and then I left, you know, most of the house stuff then was handled by (stroke victim name*).

But after her (stroke victim name*), I handled both, all the household stuff and looking after (stroke victim name*) and short trips when necessary to get provisions and things like that. So it's very much home-focused with most of my time spent at home, instead of maybe 50% of time spent out of the house before her stroke. We kind of did, you know, independent things. She did stuff around the house, and I did stuff outside the house. (P.7)

And just meals were a big problem for me at that early, in those early stages. I realized that I was going to be the meal preparer, and I had never spent any time in the kitchen at all. I could do well to make toast or something like that, or I could put stuff in a microwave, but I had never cooked a meal in my life. And to me that was the big thing was that, how was I going to prepare meals for her? Those were the kind of stressors that I had initially. (P.3)

You know, we, I know that a lot of times, you know, this is the man's domain, and this is the woman's domain, and never the two shall meet. We were never quite like that. I mean, I was always the primary house cleaner, cook, and clothes washer. But as we got older, well, especially when I started working full time, we started sharing household duties. So we were already doing that when the stroke arrived. So that was something that was good that was in place before the stroke ever happened. And like now, (stroke victim name*) washes, well, she washes her own clothes. He's (another caregiver who was also husband of the respondent) good about getting them out of the dryer and hanging them up, probably because he's just really picky about hanging things up as they come out of the dryer. (P.4)

Impact of Stroke on Abilities of Victim

Depending on intensity of stroke event, it had significant influence on capabilities of the victims. Dependability of survivors was a source of concern for the care providers because it led to increase in their responsibilities and reliance on the caregivers. Also, it was a means of guilt and shame for the care recipient to not be fully functional. According to a respondent, "I think he felt guilt that I was having to help him so much. Maybe it was embarrassing too that he was having to ask for help". (P.8)

Caregivers also mentioned that:

She had long-term memory, mid- to short-term not so good. They got her up on a walker, and so she could walk with a walker. She had a wheelchair, and if she wanted to, she could operate the wheelchair, but many times she did not move in the wheelchair. She had to be pushed. Going into the toilet or bathing, those were assisted by the (paid) caregiver. (P.1)

She is physically impaired on her right side with her right arm and right leg. The biggest impairment is a condition called expressive aphasia, which limits severely her ability to speak, to read, and to write. (P.3)

She had been very active in church activities. She had been very active in community work and so forth and all that. And driving, she's no longer able to drive. So that just limits everything basically outside the home...She is, fortunately, able to take care of her own personal needs, that is, dressing and her bathroom duties. She's able to do minimum kitchen stuff like making a sandwich or simple things like that. She does not cook. She does not do anything other than that. She can help me do laundry, but that's about it. (P.3)

He needs a little help dressing himself, a little help getting into bed. He can do a lot for himself. He, you know, he has, he can't button buttons. He has to help with toothpaste, but I don't know, I would say dressing. And he's pretty good with personal hygiene, but he can't do a lot for himself. (P.5A)

Stressors and Concerns for the Caregivers

Care providers had diverse types of stressors and concerns they were experiencing including emotional, social, and financial. One of the subjects verbalized, "Emotional stress of all sorts...Losing my temper. And I have told people unless you've done it, you have no idea what it really is". (P.5A)

Financial, she had been working, so she had insurance, and that was a help, although the insurance was very expensive at first. And we helped some with that. And just but with, since she does have the disability now, she helps out some with like she buys her own food, and she pays part of the utility and some things like that. So, it's not, I wouldn't say she pays 100% of her share, but she does help out with some of the finances. But yeah, it's still a bit of a financial strain. (P.4)

They also had different causes of stress, such as fear of future uncertainty, fear of fall of care recipient, and dread of another stroke. A caregiver shared: "We always are a little anxious about tomorrow, you know, the next day, about what could happen or what could change and so forth. So that's always a little unsettling, but there's not a lot we can do about that". (P.3)

The other thing is that I know that at her age and at her weight, and she's overweight, she's a big girl, there's a danger of her falling. And at her age and condition that's, you know, that's a major worry of mine. So that is a stressor, I'm sure, that I think about all the time. (P.3)

There's always concern that there could be another stroke. But she watches what, well, she doesn't watch what she eats quite as well as I'd like her to, but she takes her medications faithfully and, you know, things like that. She keeps on with her blood pressure medicine, so that's a good thing. (P.4)

The only one that concerns me right now, of course, is that she doesn't communicate very well about her needs or instructions that I will give her for her safety, you know. I don't know whether she fully understands it or something or doesn't hear my suggestions, so that, I think, is a problem that I don't think we'll be able to solve that in the future. (P.7)
These stressors can also influence on a caregiver. A respondent shared impact of stress as:

In fact, a year after she had her stroke, I got diagnosed with Type 2 diabetes, and probably due to the stress, and one of the habits I have when I get stressed, I eat. And I was eating all the wrong stuff. Blood pressure was up. Blood sugar was up. It was just, weight was up. (P.2).

Strategies Used by Caregivers to Cope with Stress

Caregivers mentioned diverse ranges of coping strategies that they were using/or have used. Travelling, humor, using computer/games, support group, talking to family/friend, journaling, finding happiness in other activities, reading, religion, exercising/walking, relaxation/deep breathing were highlighted by the subjects.

Oh, very helpful. Oh, yeah. I just, especially the cruises, because if you get on that boat and you leave the shore, there's no phone service. I could shut down. I figured, I said, here's the emergency number for the cruise line that if something very, very dire comes up, you can call them, and they can find me. But, you know, nothing serious. (P.2)

With stressors, I usually either read a book, play a videogame, or I just watch a movie...It gives me a mental break. It allows me to just kind of like escape for a small period of time. I'm able to, you know, get lost . . . for a few minutes, which is something very important. (P.9)

I would say the strongest influence that helped me along at that time was a stroke support group, where I was able to interact with other caregivers as well as other stroke victims. I learned about what strokes were and held a varied and an intensity and lots of other resources, sources of help... In-person is the best... Because when you meet someone in person, you see that person. You can look into their eyes, and you can hear, and you can see what that person is talking about even more than hearing them. It's just a much closer relationship to someone else rather than Zoom meetings. Zoom meetings are the next best, but the in-person is much better. (P.3)

It was more of a blog, if you would, probably a blog would be a better thing of calling it, where I could tell what was happening that day or every two or three days. And then people could respond and send comments back. And I could just do that through email. So that was very helpful. It gave me a way to post positive things. And then, like I said, I got feedback from, positive feedback from friends, from friends that we had known, you know, 10, 15 years beforehand. So that was, I did want to mention that one earlier. That was probably as much of a support group as anything too, you know, just being able to do that. It was a form of journaling and being able to express that and then to have positive feedback from that. (P.4)

Probably one of the best stress reliefs that I've had is the granddaughter that was born the same year that (stroke victim name*) had the stroke and then the one that was born about four years later. Getting to take care of them was a huge relief, you know. For one thing, when you're taking care of babies, you really can't worry too much about anybody else. But just the light and joy of, you know, I love being with babies and toddlers and preschoolers. (P.4)

I think it really helps a lot, and I do also watch a lot of television, probably too much. I like to watch movies more than anything else. And, yeah, sometimes, you know, if you just stop and take some deep breaths and try to get your mind on something else, and maybe if I can find some little game to play on the computer or something, gets your mind off of that. (P.6)

Social Support to Stroke Caregiver and Care Recipient

Availability and nature of social support was a comprehensive theme identified from the collected data. Consistency and adequacy of social support was questionable for some of the respondents due to other priorities and restrictions of family and friends of stroke caregivers and care recipients. However, some of the participants found significant instrumental social support and help provided by their social network. Not only unpaid informal social network was found to be beneficial, but also paid help and other services was a great source of assistance for some of the participants. Emotional support and appraisal were also the types of social support that were sought by some caregivers. Information social support was obtained from formal and informal means; however, some caregivers self-taught or research stroke-related information by themselves.

Support group was highlighted as means of social support by some of the respondents. This was means to seek help for themselves; some respondents used support group as a platform to give back/serve the stroke community. This theme can be categorized in sub-themes of Consistency and Adequacy Social Support, Role of Paid Services, Emotional Support and Appraisal, Availability of Informational Social Support, Role of Support group and Other Services.

Consistency and Adequacy of Social Support

Reliability and availability of social support accessible to stroke caregivers was not always as good or as desirable. Their social network may have other competing priorities or relationship dynamics that can impact offering of instrumental social support. It was also mentioned that the reaction and support from the social network around them also changed over time. Respondents mentioned that:

They came mostly for moral support. They, from 2011 to '15 or '16, they brought the food from the food store. The (paid) caregiver would call a list on the cell phone, and they'd come Sunday with bags, bags of food and bring it into the house, say hello and say goodbye. (P.1)

She lived far away, and she would come maybe for a birthday or Christmas, that kind of a thing...And the other brother and sister-in-law, as I say, they bought the groceries, but then when I retired, I started doing that duty, and then I guess that gave them the idea that they didn't need to come anymore. I mean, they came. They came to pay the caregiver, but it would be a very short visit. Usually, the brother would come and just park in the street and ask the caregiver to come out on the sidewalk. He'd pay her and he'd . . . so I was very disheartened to find out that most of the time he did not take the time to come out of the car and into the house to say, hi, (to the stroke victim), how are you doing this week? And he had a reason and that was he had to go back to his work. (P.1)

They could come do things with him. Occasionally, I think, let's see, I think his son took him, and since January, I think his son took him out for lunch once, and his daughter took him out for lunch twice. (P. 5B)

I can say it was real good at first, you know, when he was in the hospital. You know, my kids would come all the time in their spare time, and they would help out. And I told them one time, you know, y'all need to take turns of, so I set up a little schedule for them. You know, wasn't, it wasn't necessary that they all needed to be there at the same time. Why

didn't they spread out over the day, you know, like come an hour or something and sit with him . . . and they would come and do that. And that was very helpful to me at the time, you know, when he was in the hospital, where I didn't have to be there all the time.

And, you know, and then they helped me get the house ready when he was going to come home and everything. But seemed like after we got home and everything, it's just kind of like now it's boiled down to mostly holidays when they come. So that's about, I know they're all busy, you know, with their lives, and they all work, and they've got stressful jobs and things like that. But as far as now, them just coming over to, well, hey, you know, I'll come over and stay with Dad, or I'll come take Dad out to eat or something to give you a break, and I don't have that any more...The one in-law, my son-in-law that I had that was real good about doing stuff like that, you know, he'd be the one telling me that I needed to get out and do something on my own. He passed away. So I guess he was the one that was more into that. (P.6)

I think their reaction has changed, yeah. Of course, they're older. I think, I can look back at my life, you know. They're older, you know, and like they're in their late-50s and approaching 60, and they're probably more tired than they were when they were younger. And, you know, they have their families and their jobs and all that stuff, so. (P.6)

It would be like depending on the situation. But, you know, like my daughter said, we may not come over all the time, but if something happens, catastrophic, something happens like that, when he had the stroke, they were all there. You know, they were there when I needed them for something really, I guess really important, catastrophic or something like that. They were there, so. (P.6)

I think it was more at the beginning that they did that, you know, to call and check on you to see how you were doing and that type of stuff. But now, you know, since it's been nine years, it's not really like that. You know, I guess by now, they just figure, well, you doing okay, whatever, right? (P.6)

And even when we were meeting with that couple once a week for, you know, for a meal, a noon meal, it was just on that day. It was never, you know, anything else during the week that they would, maybe if, I do take that back. A couple times, maybe if there was a funeral we would go to out of town, a mutual friend, that they would come by and pick us up and take us, but, to that, but, you know, just not anything else during that week that we would see each other or anything.

So, I'm, you know, like I said, I think it's just that I wish he had, he (stroke victim) has a friend that calls once in a while, but their friends never invite him to go out, to get coffee or anything like that. You know, and he wanted to go, if somebody wanted to go and have coffee with him, it would be great. You know, I would take him there, and I would just leave and let him be there for a while by himself, so he would feel like he was there by himself, or he had a friend or something. (P.6)

That would be great, you know, if they would just come and say, you know, I'll stay two hours, and then I would go out, and I would stay out two hours. You know, maybe I could go shopping somewhere for myself or something. You know, but, and another friend he

has, he lives out of town, and he's, oh, yeah, I want to come see y'all and spend the day with you, come, I'll come up there. And I even gave him directions how to get to my house, and that's been over a year ago, and I never heard back from him.

So, you know, people have good intentions, but they don't go through with it, I guess. So, I don't know. So, you know, I just learned not to depend on anything like that, don't have any expectations. Or people, you know, people going to tell you you going to come do all that, and I just think, yeah, right, okay. You know, just like. (P.6)

We've had our neighbors have all asked, you know, that if, you know, if you need something, please let me know. But I'm reluctant to call on them to do anything. Well, for one reason, I haven't needed them to. But I, you know, there's always a hesitancy to call on someone else to help you. Our daughter, although she's a single mom and she is still working, she has been very helpful in bringing grocery items or ordering grocery items for us and having them delivered here. And she comes regularly over to see us once or twice a week. And, you know, if need be, I can always call on her, or my other two sons that live here in the area, although they're still, you know, they have families of their own and they're still working. But no one really that I could call and have them come over and, you know, spend an afternoon, or spend the day or something like that. I just, if I have to go out, I always make sure that it's a, I'm gone as little time as I can. And I always make sure that (stroke victim name*) has her phone, and I have my cell phone with me when I'm out of the house. (P.3)

Social support was strong for some of the participants, and they were satisfied and grateful for the network of social people around them that helped them in caregiving duties. A respondent mentioned that: "his parents. They come in and check on him every once in a while, make sure that's he's eaten, you know, ask if he needs anything to drink". (P.9)

I really felt proud, proud and happy that, you know, that they would do that. And, you know, and the other son, he offered us, he offered to, we could come over his house, but he didn't have lights either. So, but the one that came and got us, his electricity never did go out, so, where he lived. He always had electricity, so that was good, so. (P.6)

One thing I started doing, I guess, after about three or four years, is she (stroke victim) let me go on a trip once a year by myself. And she was able, for the most part to watch after herself and take care of herself. And our son was here, he could kind of help her out. We'd have friends and neighbors that would check in with her and maybe take her out to eat or something. But I'd go off, I drove out to Las Vegas on one trip, and then I got into the cruising bug, and I started to go on cruises. (P.2)

My kids did play a big role in it for me. You know, they came over and helped me like straighten up the house, and my son-in-law built me a little ramp for him to go up, yeah,

because we thought he was going to be in a wheelchair when he came home, and put the bars up in the bathroom, around the bathtub and all that kind of stuff. And so then my daughter and I went shopping to try to figure out what all we needed, you know, as far as I guess toiletries and things like that, like the, and then got the bed in and all that stuff. (P.6)

(Parents of stroke victim) They've been able to do the financial paperwork, some stuff I would never have been able to even so much as crawl through. They've been trying to help me go back to school, so this way, I can get a degree for a better job, so I'll be able to make more money. And, you know, if anything were to happen to them, I'll at least be able to bounce back that way. (P.9)

They usually come over and check on him every few hours, you know. They have a spare key, so they just let themselves in and, you know, hey, (stroke victim name*?), are you hungry? Do you need anything to drink? You know, how are you feeling? (P.9)

Role of Paid Services

Formal social support for instrumental needs was used by subjects, which was found to be helpful for them. It would provide them some time to take care of their other important duties.

I had the home health people come and give him his showers and things like that. And so, the person that I hired was just only sitting with him, you know, while I went to the doctor maybe and got out just like four hours at a time so I could go and, if I had to go to a doctor's appointment, I could feel comfortable somebody was there to be with him in case he fell or needed something. But, and that, I only had that for about four weeks or something. (P.6)

So, the (paid) caregiver would walk her from the bedroom, bed to the walker, walk her to the bathroom, walk her from the bathroom all the way forward through the house to the dining area, sit her down, have breakfast, walk her back with the walker to the easy chair, and she would sit. And then the same process for lunch and going to the bathroom and then ultimately dinner and going to bed, all done with a walker. (P.1)

Emotional Support and Appraisal

Emotional and appraisal social support was mentioned by some of the subjects as source of help and motivation for them. Getting reassurance that they are doing good job as a caregiver and getting moral support was a great support for them. Participants verbalized that:

Yeah, my (caregiver's) parents did. They saw him right after he had his stroke, and a couple months ago we had dinner, and we were, you know, they were commenting on how much better he looked and how much more he was able to communicate. (P.9)

Mostly just the support for me, just the sounding board for me to talk to. Whether he (son of the caregiver) was listening or not half the time, I don't know. But it was, I could go in there and I could talk and like we were saying earlier, you know, that's just being able to talk to somebody is really good therapy. I mean, you're not necessarily learning anything. You're not listening to someone else talk to give you ideas. You're, but the fact that you're talking is, in itself, is a good therapy. (P.2)

Father's Day. And we had the families, both the boys' families came over and visited with us at different times, and my daughter came over also at a different time. Both of them, they brought me cards and they brought me some excellent donuts. So, yeah, yesterday was good. Yesterday was good. They're always checking in. They come over and visit, oh, once or twice a week, one or both, or maybe one or two of them will do that at least once a week. And they're checking on us even by telephone, if we, you know, other than that, but I feel good about that. They make me feel good about that.

And you know, one of the things, (interviewer name*), that older folks do, parents especially, is that as you get older and you think back on your life and you realize, you know, you're not building memories anymore, you're living on memories. (P.3)

Availability of Informational Social Support

Formal (health system and/or paid services) and informal (social/ unpaid) means were a source of informational social support as mentioned by some of the stroke caregivers. Support group(s) were means of informational social support as well. This information was related to stroke and/or stroke caregiving. Few subjects relied on self-research and their curious nature to learn about these topics.

And near the end, the nurses up there, the therapists up there were going to get equipment for the house, you know, wheelchair, a transfer seat for the shower or tub, whatever we're going to use. You know, walker, the thing, the tools we would need. (P.2)

My go-to source would be Google, just a lot of Google. In fact, that's how I found some stroke support groups, which led me to the caregivers group was through a Google search. And, like I said, as far as day-to-day things, I just did them. I didn't have to go out and, you know, relearn how to do these things. How do I do the laundry? How do I cook? I already knew how to do all this stuff, and how to run a house, and how to care for her. I just, well, I just knew. I think part of it was like I would, you know, maybe I was thinking,

well, if it was me, this is what I'd like someone to do for me, so I'll just do that for her. (P.2)

I just, I mean, the Caregiver Support Group, you know, we used to meet once a month in person, and I would just, I would gather information from what other people were doing with their spouses and learn from that, just, you know, what they were dealing with. And I thought, well, I could use that information and just, you know, kind of pick-up little tidbits here and there. (P.2)

Study, study, study, and ask a lot of questions. I was even, I get angry sometimes when I think back about those times, is that I didn't even know what a stroke was, and nobody even talked to me about that until we got into the rehab, the long-term rehab facility. And then it was the nursing folks there, as well as the therapists and the fellow that was in-charge of the physical therapy program, that really told me about what was going on with her. That she had truly had a stroke, and that it was a blood-clot type stroke. And the, and it affected her right side, which meant that the damage was over on her left side of the brain, and that her condition was called, her major condition was called aphasia. .. I was in total ignorance until, well, like three months after she had her stroke or maybe four months. But to answer your question, I bought books. I did a lot of online stuff. I've got different, you know, sources of reading and so forth and study. Let alone on the same line, I was able to ask questions in the stroke support group meetings, and I could see other folks there that had had strokes, and I could hear them talk about what they were feeling and so forth and the caregivers that were in that meeting and talk about what was going on with them. (P.3)

Because of my training, and I had some brain-injured students in a high school I taught with. My husband is a social worker, and he worked at a neurological hospital for a while, and he's worked in nursing homes. So, we're more maybe aware of some of the healthcare needs of people who have different, you know, major health issues. So, we (parents of stroke victim) were not, we were not clueless. (P.4)

Mostly we ask his brother. His brother works in a hospital, so he can usually just walk up to one of his colleagues and ask them for information. I think that's how we found out about the (*name of organization) in the first place, is through one of his brother's friend's colleagues. And usually, he comes up with some good information for us. (P.9)

One of the subjects mentioned her concern that:

I didn't know the questions to ask is the problem, you know. This is a whole new thing. So, nobody is forthcoming with anything unless you ask a question. But if you're not knowledgeable, you can't ask a question. (P.5B)

Role of Support Group and Other Services

Support groups and other such services were means of social support for subjects. Few subjects were associated with a support group for a long time and were able to aid the caregivers recently assuming the caregiving role. This platform was a source to ventilate and share their experiences without fear of any repercussions and hesitation. Knowing that others in the group belong to similar situations helped them relate to each other.

I had been in the group for 15 years. And in the early years, I mean, it's a totally different crowd now. In the early years, yeah, I would sit there, and I'd listen, and I'd learn two things. And I had learned a few little tidbits of things to look for or things to check or assess but also learned that there were people with their spouses were in a lot worse shape than mine was at the time, and that was fortunate. And I learned that there were a lot of women in the group whose husbands had strokes and realized how fortunate I was, because (*name of stroke victim) was just very easygoing. You know, she kind of whatever I said went. She didn't question it. She didn't fight it. She didn't mind. She enjoyed it because she didn't have to think about it. Because I did all the thinking. So that was just one less thing that she had to worry about. And I learned in these, in the caregiver support group, that a lot of the women whose husbands had stroke, it was more of a challenge because the husband wants to be the man of the house. The husband drives the car. The husband pays the bills. You know, the husband does this. They couldn't do it anymore. So it was kind of relief to me knowing that I was sitting in pretty good shape, you know, with (*name of stroke victim), and so it made me feel kind of good about that. (P.2)

The good thing about our support group is, you know, when we meet, it's just the caregivers, and we don't bring our spouses. I mean, I've been to stroke meetings where it's the stroke victim and the spouse. But this is just the caregivers. We do not bring the spouses. And that way we can say what we need to say, because a lot of times there's things that you're feeling or thinking or worried about you can't say in front of your spouse, you know, and it gives us a chance to, you know, truly open up. And as you saw in our meeting, you know, we, it's not all roll up our sleeves, get down to business and try to solve problems with our spouses, and, you know, dealing with this. We talk about everything... But it gave us an outlet with each other that we could talk about things. And I said, talk, say what we need to say. You know, you don't have to worry about hurting anybody's feelings, which is therapy in itself. (P.2)

I was fortunate enough in the time that she was in rehab to find a stroke support group, and that was a lifesaver for me. And that group was the, which I'm still active in, still participate in, was a lifesaver, where I found out that there were other people who had been in the same situation that I was in at that time and that had made it, had survived. And I learned a lot about how to get along, and how to get things done, and to not be paralyzed with worry about what was going on. That was the biggest help for me at that

time. Plus, it taught me to ask questions. If I didn't know something, it was okay to ask. And that was something new to me. Prior to that, being an engineer, I had the mentality that if you didn't know something, you figured it out. And, but I would say the strongest influence that helped me along at that time was a stroke support group, where I was able to interact with other caregivers as well as other stroke victims. I learned about what strokes were and held a varied and an intensity and lots of other resources, sources of help. (P. 3)

Respite or Self-Care for Caregivers

Some of the caregivers were able to manage time for themselves and realize the importance of doing so. A caregiver said that: "And I have just gotten back from the beach for, with three friends for four days. I discovered that was important for me to be away...it kind of clears your brain". (P.5A).

The advice that I got from someone in the support group was that I needed to make an appointment to eat one hot meal a day. If that's, if that was all I ate, it needed to be a hot meal at least one a day, and that helped. (P.3)

So, I mean, I always felt, like I say, I always said, you know, the best thing I can do to help her is keep myself healthy and take care of myself first. It's like, you know, on the airplane, put your face mask on first and then help your passengers. And you've got to help yourself first, otherwise, you can't help other people. And so I always preached that. And I kind of adhered to it a little bit, but, you know, most of my focus was on making sure she was okay. I was just constantly, anytime we did anything, whether it be out eating dinner or on a cruise or here at home, I was just constantly, my brain would be constantly making sure that her environment was safe for her. And make sure there's nothing on the floor that she might trip on and things like that, or just, that's just kind of the way my brain works. I was just constantly looking, constantly thinking five steps ahead. (P.2)

However, some of the caregivers did not have the opportunity to take advantage of a break from the caregiving role due to caregiving as active concern or guilt from leaving the care recipient unattended if they go out without the care recipient.

I mean, I worked 10 hours a day. Then I would go to (* stroke victim's name) for three-and-a-half hours and come home and go to bed and get up and go to work the next day. There wasn't really a break except on weekends. (P.1)

If a family member from her family had come forward and said, let us come three days a week and you don't come. You go, read your books, go to work, do your job, relax, we'll relieve you. That just never happened. (P.1)

I really treated it like a woman would treat having a child at a daycare center and then maybe getting grandmother to watch the child once or twice a week. But knowing that that child is your total responsibility, and no one else can be made responsible or blamed, Grandma, Aunt, nobody else. That's kind of the feeling I had. So as things progressed, then I had more of a hand in her care as a support (P.1)

And I think a couple of times, we had the opportunity for my husband to stay with our son, you know, at the house, at their house while she and I went shopping, and we got to just go and have a meal by ourselves. You know, and that's another thing, don't get to go out with the lady friends to visit or socialize much, so. (P.6)

I worked until I guess maybe a couple of years before he had the stroke, but I had the opportunity, like I said, to go and meet some of my lady friends for lunch or to go shopping with them. And I haven't had that, I don't have that opportunity now. So just very seldom have I gone off and met them. I guess I feel guilty if I go out somewhere and leave him at home because I know he wants to go out and, you know, and he would like to go out and go with me or go out, I guess I should say, or leave the house. (P.6)

You know, it would just be nice if, and like I said, if somebody wanted to, I want to go out with somebody, I feel guilty about, I guess I don't know why I feel guilty about leaving him by himself here while he's by himself while I'm out going somewhere. Although, and then I stop and think, well, if the tables were turned, I know what, he would be going, leaving me here. But, you know, I guess because I know he wants to get out and go, and he likes to be with people more, I guess, than I should say I do or something, I don't know... Leaving him alone, you know, while I'm out having fun, I guess I should say. Not having fun, but I'm out with friends, and he's staying at home, you know. He's having to stay home by himself, you know. I just feel guilty because, you know, I just feel guilty. Well, I know he would want, you know, he would want to go. He'd want to go, you know. If I go out to meet somebody for lunch or something, he would want to go because he's, you know, said that, he would want to go. (P.6)

Conclusion of Results Chapter

To summarize, this chapter has description of the demographic background of the study subjects. Major themes and sub-themes identified from data analysis are elaborated with quotes from participants. There are a total seven main themes. As mentioned above, two of those themes are broad and are further bifurcated into sub-themes (Refer Table 2).

CHAPTER FIVE

Discussion and Conclusion

Introduction

Chapter five contains discussion of study results and how these findings align with existing literature available on the topic of interest. Later, study limitations are also reviewed. In reference to study results, inferences and suggestions for future studies and practice are also provided.

Discussion

There were seven major themes emerged from this research. The themes found were: “*Work Life Balance*”, “*Reaction of Other People or Family to Stroke*”, “*Expectations and Responsibilities from Caregivers*”, “*Impact of Stroke on Abilities of Victim*”, “*Strategies Used by Caregivers to Cope with Stress*”, “*Social Support to Caregiver and Care Recipient*”, and “*Respite or Self-Care for Caregivers*”. The discussion on the themes below is organized according to the table of results provided in chapter four.

Work Life Balance

“*Work Life Balance*” was a theme identified in recent stroke caregiving literature (Kokorelias et al., 2020). Kokorelias et al. (2020) mentioned that caring for a stroke victim is round-the-clock work and looking after duties other than caregiving requires reorganization of caregiver routine. In general caregiving literature, need for flexible working hours and support for policy structure to assist caregivers is explicitly recognized (Kitamura et al., 2021).

In this current study, “*Work Life Balance*” was discussed in reference to managing job with caregiving tasks. Stroke caregivers who were working while still caring for stroke victims were required to balance work life with caregiving duties, which was a challenge for them. It

was also highlighted by some study subjects that not being able to achieve work life balance with caregiving responsibilities led to quitting their jobs or impacting their retirement plans.

Reaction of Other People or Family to Stroke

“Reaction of Other People or Family to Stroke” was a theme which was not found in the literature. This current study identified this novel theme that elaborates the response of people surrounding the stroke survivor. It was revealed by a stroke caregiver that not everyone is ready to respond appropriately to a dependent person, which can influence the social engagement of a care recipient. Hesitation noted in the reactions of others could be due to lack of information and insight about the needs of the care recipient. Moreover, it could be due to their unexpressed apprehension of being criticized and blamed while being around a dependent person in case of any misfortune, such as fall. Hence, people may tend to avoid engaging with stroke victims and their caregivers.

Expectations and Responsibilities from Caregivers

Most of the sub-themes under *“Expectations and Responsibilities from Caregivers”* are predominantly found in literature.

ADLs and IADLs

The dependency that can be caused by stroke restrains the stroke victim from caring for themselves in terms of ADLs (Bosma et al., 2020). Informal or family caregivers take primary accountability in caring for older adults with stroke by assisting them with ADLs (Hesamzadeh, et al., 2017). A study of German older adults with stroke mentioned that most of the survivors were reliant on their caregivers for provision of ADLs and IADLs (Albrecht et al., 2016). A median of 13.9 hours in a week were invested on ADLs, and 22.2 hours a week were invested on supporting care recipients in IADLs (Albrecht et al., 2016). This current study results are in line

with the above-mentioned literature. Care providers were heavily involved in supporting stroke survivors in performing ADLs and IADLs particularly in the first few days and months after having the incident of stroke.

Home Modification

Regarding sub-theme “*Home Modification*”, caregivers in this study mentioned that they practiced home modification and drafted home set-up to ensure it would be appropriate and safe to be used by the stroke victim. Caregivers assumed the responsibility to alter the home for the use of the stroke victims. Similarly, literature also mentioned that stroke caregivers inquire about (Krishnan et al., 2018) and need means for home adjustment (Lutz et al., 2017). This may include modifying flooring, adding handrails (Lutz et al., 2017), having a ramp for getting inside the house, and setting-up restroom grab bars (Sutter-Leve et al., 2021).

Care Management

“Care Management” as a responsibility of the caregiver is also highlighted in stroke literature (Lutz et al., 2017). This includes coordinating schedules, negotiating with service suppliers, getting the stroke patient ready for appointments, and adjusting work life of a caregiver to attend appointments (Lutz et al., 2017). Likewise, caregivers of this current study mentioned their responsibilities of care coordination from scheduling and organizing to following-up for decision-making. Respondents did mention that they had to coordinate between more than one provider as well as be on the top of managing care of the care recipients.

Constant Vigilance

Constant vigilance is a new theme that is not discussed much in recent stroke caregiving literature. This current study revealed that caregivers expressed the need to continuously look after care recipient needs and ensure their safety. Due to the severe impact of stroke, the

physical ability of the stroke survivor can be highly compromised requiring significant accountability for caregivers to be vigilant to prevent or mitigate harm from falls and other incidents. This is a demanding responsibility for caregivers, which caused them to stay with the care recipients most of the time. The duty of constant watchfulness was found to be a contributor to lack of social engagement due to full-time caregiving duty. The impact of caregiving on the social life of caregivers was a stressor identified in this research study.

Impact of Gender Roles

In general, caregiving is a concept that is closely related to gender norms (Penning & Wu, 2016; Sharma et al., 2016; Swinkels et al., 2019; Uccheddu et al., 2019; Xiong et al., 2020; Yu et al., 2019). Women are typically considered to be caregivers due to the nurturing responsibility attributed to them.

A meta-analysis between 1946 and 2018 studied public views in the United States on the gender roles and stereotypes (Eagly et al., 2019). It was found that equality of both the genders in terms of capability and aptitude improved (Eagly et al., 2019). As compared to men, women showed higher benefit with time on emotional and empathy measures (Eagly et al., 2019). As compared to women, men showed no significant change or benefit over time on ambition and agency measures (Eagly et al., 2019).

In this current study, 50% of the subjects were male and 50% were female. On perspective of gender and caregiving as revealed by this study, a subject mentioned that he found himself to be in a better place as compared to female caregiver(s) of the support group as caregiving was harder for female spousal caregivers because their male partners were typically head of the family. Hence, caregiving duties can challenge existing gender roles and responsibilities allocated in a family unit.

A few subjects mentioned that they were following established gender norms prior to stroke and had to take on new imposed responsibilities with change imposed by stroke. For example, a male caregiver helping with cooking and a female taking care of car after stroke. So, gender roles were also observed in division of family responsibilities.

Impact of Stroke on Abilities of Victim

The effect of stroke on the victim can be distressing depending on the intensity of stroke, whereby an individual's sensation, cognitive, vision and physical abilities can be compromised (American Stroke Association, 2021; Centers for Disease Control and Prevention (CDC), 2020). This almost always means that they must receive help and support from others. This current study also helped explore and understand the influence of stroke on the functionality of the survivor. It was found that a severe stroke can make a person physically handicapped and/or impair his ability to communicate. This can change a person's life from very active to dull. It can also impact their day-to-day living and ability to earn a livelihood.

Stressors and Concerns for the Caregivers

Byun, et al., 2016 conducted a study to measure a sense of unpredictability in stroke caregivers of older adults. It was identified that unpredictability was linked with other variables such as spousal relationship ($p=0.01$), depression ($p=0.001$), decreased coping ($p=0.002$), decreased functionality ($p=0.009$), increased age of informal stroke care provider ($p=0.019$), more strain ($p<0.001$), other diseases ($p=0.035$), insurance ($p=0.008$), and multiple strokes ($p=0.0034$; Byun, et al., 2016). A few subjects from this study also highlighted the fear of unpredictability of patient fall, uncertainty of the future, recurring strokes, and future in general.

Stroke caregiving can be a source of strain for emotional (Pesantes et al., 2017), social (Menon et al., 2017) and financial aspects (Menon et al., 2017; Pesantes et al., 2017). Emotional

strain has also been recognized as a source of fatigue and poor motivation for informal care providers as identified in a qualitative study by Pesantes et al., 2017. It was also found that the caregivers felt that investing a lot of time on caregiving constrained their social life and restricted their ability to spend time on self and other people (Pesantes et al., 2017). Similarly, this current study revealed an emotional toll of caregiving on caregiver mood. It was also found that social life of caregivers was affected due to being limited to home.

Regarding financial stress, Pesantes et al. (2017) found that inability of caregivers to maintain a job can influence their salary. Not many participants in this current study mentioned financial issues as a major contributor to stress. However, one participant mentioned that the limited ability of a stroke survivor to cover financial needs is still some monetary stress.

Strategies Used by Caregivers to Cope with Stress

The literature identified some of the means of coping for stroke caregivers, such as watching TV, being involved in religious activities, making food, exercising, going to work, reading, establishing a routine, and doing things that used to enjoy prior to being a caregiver (Pesantes et al., 2017). Some of the similar activities are used as means of coping by the subjects in this current study including reading books, searching enjoyment in different tasks, being involved in faith/religion, and walking. Interestingly, travelling was mentioned by a few subjects in this study as a unique coping strategy. This allowed them to relax their mind from the caregiving role. Moreover, blogging and journaling was identified by a participant as a mean of “positive feedback”, which is kind of an innovative strategy used by a caregiver.

Social Support to Stroke Caregiver and Care Recipient

Instrumental, appraisal, emotional, and informational support are the four categories of social support identified in the literature (University of Pennsylvania, n.d.). Discussion on all

four types of social support were mentioned by the subjects in this study. In the literature, social support in general was found to be linked with better quality of life of stroke caregivers ($p < 0.01$; Abeasi, 2020). Social support was found to be a variable linked with reducing caregiver's burden of caregiving ($p < 0.05$; Han et al., 2017; $p < 0.0001$; Shiba et al., 2016). Particularly, family social support was identified to be related with caregiver strain ($r = -0.295$; Akosile et al., 2018). This current study results are also aligned with these studies and the findings of Shiba et al. (2016). In line with Shiba et al. (2016) and Akosile, et al. (2018), it was also found in this study that the informal social support from family and friends is vital. Consistent with current study results, Shiba et al. (2016) mentioned that formal social support can be a means of informational and instrumental support, but formal social support was not recognized as a vital means of emotional help for the caregivers.

Consistency and Adequacy of Social Support

Social support for some participants was found to be consistent and reliable. However, it was not so dependable for others. This current study identified a newer perspective on the consistency and adequacy of social support available to them. Since the data was collected from diverse sources, it allowed the investigator to enroll subjects from less than a year of caregiving experience to 15 years of caregiving experience. This diversity allowed the researcher to look at changes in availability of social support over time. There is not much recent literature on stroke caregiving that takes into consideration the duration of caregiving as a factor impacting social support adequacy. This study revealed that social support is better in the beginning of stroke caregiving; however, social support may decline as time passes by.

Role of Paid Services

Lutz et al., (2017) also discussed formal resources in their caregiver model for transition from an inpatient rehabilitation facility to the community. There are several paid services available for caregivers to use, such as home help, nursing home, day-neuro services, and respite care.

The current study results also revealed that paid services were helpful to a few participants. However, their use care for long term was in question for some subject(s) due to affordability or/and coverage issues.

Emotional Support and Appraisal

In line with the literature (Akosile et al., 2018), this study also revealed the presence of support from family and loved ones of caregivers particularly in the initial stage of the caregiving continuum. Though social support of caregivers may have other struggles of their own life, emotional support or having someone to ventilate emotions was helpful to prevent or curtail burnout for caregivers in this study.

Appraisal social support that helps in assessing one's ability to combat a challenge (University of Pennsylvania, n.d.) was explicitly identified by one of the subjects of this current study. The social network of the caregiver shared positive comments on the recovery of the care recipient which was reassuring for the caregiver to reflect on her caregiving abilities and accomplishments.

Availability of Informational Social Support

In the literature, there are different interventions available for provision of informational support to stroke caregivers, such as community-based intervention (Pitthayapong et al., 2017). This current study revealed that health facilities or health care providers were means of good

informational support for some of the respondents, but not for all. In this current study, some respondents used informal means, such as a loved one working in health industry or searching on their own to learn about stroke related care and caregiving.

In a research study conducted in India, it was found that approximately 92% of the requests shared by stroke family caregivers was related to stroke informational support (Kamalakannan, et al., 2016). Zawawi et al., (2020) found in a systemic review that requests for informational social support is a need identified by stroke victim and their caregiver in developing nations and in developed nations as well.

Role of Support Group and Other Services

Christensen et al. (2019) found that having a peer support group creates a feel of belonging to a community and empowered stroke victims and caregivers. Similarly, since the sites of data collection for this current study were support groups, advantages of a support group were mentioned by many participants of this study. This provided a platform to learn and share about their experiences.

However, this current study data was collected during the COVID-19 pandemic. COVID-19 conditions impacted the structure and process of some of the support group(s). For example, the local support group meeting which occurred in church prior to COVID-19 was conducted virtually at the time of data collection for this research. Virtual sessions were not always the top priority of everyone attending the sessions. This could be due to lack of human touch, conflict of meeting time, or conflicting priorities. It is worth mentioning that the average age of stroke caregivers for our sample was 72.8 years; it is our assumption that meeting virtually may not be user-friendly for this age group. There is a dearth of literature on role of stroke caregiver support groups in provision of social support in the era of COVID-19.

Respite or Self-Care for Caregivers

This theme is also covered to a certain extent in the stroke literature. Lutz et al. (2017) mentioned that caregivers may not have situation for self-care. The American Stroke Association (2020) mentioned that having a break is significant for a caregiver. For example, respite care to release the caregiver for a short break (American Stroke Association, 2020). This current study revealed that some of the participants were able to incorporate periods for breaks in their routine of caregiving, while others did not have the privilege or resources to do so. Their stronger social support system who cares for the caregivers was not able to provide that much support.

Limitations

One of the limitations of this study is that there was no racial diversity in the participants as all the subjects were Caucasians. It was not planned to recruit only Caucasians in this study; however, it happened by chance that no other racial groups volunteered to participate in this study. Since, caregiving is deep-seated in society norms, it would be interesting to look at perspectives of other racial groups on social support and stroke caregiving.

Since this study was planned and implemented during COVID-19, the interviews were carried out on the phone. Not being able to capture non-verbal communication clues on the phone, such as expressions and gestures could also be a reason for missing some context and details from participant narrative.

Another limitation of this study could be due to study design. This is a one-time cross-sectional sample asking participants to reflect on their experiences but does not attempt to or capture their changes over time.

Conclusions

This study helped to answer the research questions:

- 1- How is Pearlin Stress Theory applicable for stroke caregiver population?

The Pearlin Caregiving Stress Theory was developed based on an Alzheimers' caregiver population. This current study illustrates that this theory is applicable to another population of caregivers. The responses from participants of the study revealed that all six constructs were directly or indirectly related to stroke caregiving. For example, the *context and background construct* of caregiving includes family composition (Pearlin et al., 1990). The majority of subjects of this current study revealed that family composition was a matter that affected them while caring for stroke victims. For example, living around extended family and family dynamics impacted the caregiving experience of the participants. Hence, background factors of the caregiver impacted the stressors and resources available to caregivers.

Primary stressors in this case would be stroke-related subjective and objective strain on caregivers, such as responsibility to perform ADLs, care coordination, home alteration, and constantly watching the stroke survivor. *Secondary stressors* construct include the theme of work life balance issues due to the caregiving role, but is not candidly counted as a caregiving task. The construct of *Secondary Intrapsychic Strain* construct can be linked to this study in form of caregiving appraisal given to a caregiver on progress made by a care recipient. Moreover, some caregivers spent a long enough time providing care for a stroke victim that they deemed themselves comfortable in supporting other caregivers in a support group. *Coping* and *Social Support* concepts of the *Mediators* construct (Pearlin et al., 1990) were clearly found among the themes of this current study. Strategies caregivers used for coping and four types of social support (instrumental, appraisal, emotional, information as cited in University of

Pennsylvania, n.d.) were found in this study. The *outcomes* construct of Pearlin et al. (1990) was hard to relate in this cross-sectional study. Following participants and/or applying tools specifically to gauge their outcomes as a result of caregiving is needed to fully support the *outcomes* construct of Pearlin et al. (1990) theory.

Figure 2: Pearlin et al. (1990)

Pearlin's Stress Theory

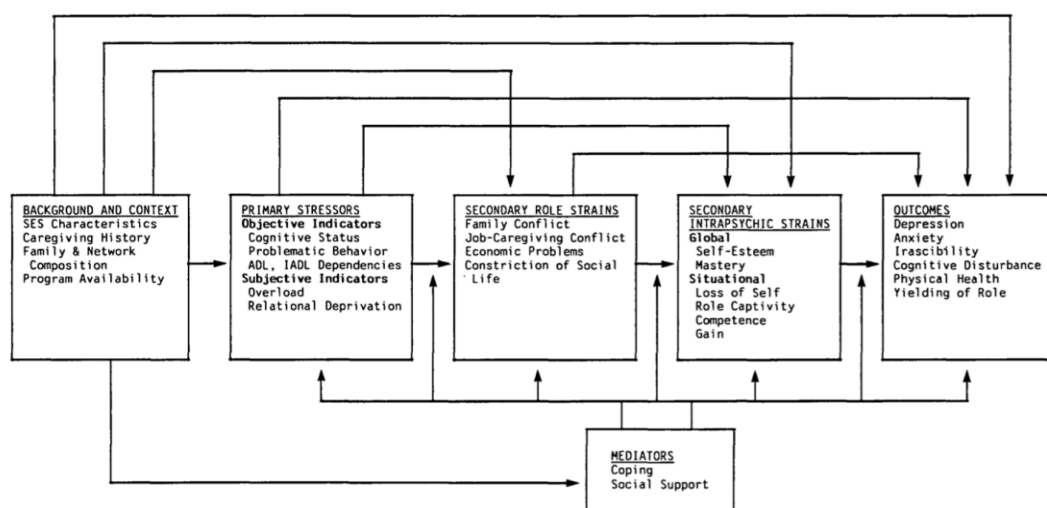

Figure 1. A conceptual model of Alzheimer's caregivers' stress. The stress process is made up of four domains: the background and context of stress; the stressors; the mediators of stress; and the outcomes or manifestations of stress.

2- What are responsibilities of stroke caregivers through the care trajectory?

As recruitment was conducted from varied sites, the researcher interviewed caregivers when they were in different phases of caregiving. Some were in the initial phase of the caregiver role, and some performed the caregiving role until death of the stroke victims. It was deduced that there were a wide range of expectations associated with the caregiver role as elaborated in the theme *Expectations and Responsibilities from Caregivers* that includes sub-themes of *ADLs/IADLs, Home Modification, Care Management, Constant Vigilance, and Impact of Gender Roles on caregiving duties.*

- 3- What is the influence of social support on the perceptions and experiences of informal stroke caregivers?

The theme *Social Support to Stroke Caregiver and Care Recipient* clearly emphasized on how the availability of social support or lack of social support can influence views and experiences of caregivers. For example, it can impact self-care of caregivers. Participants emphasized need for more social support to provide temporary relief from the constant role of caregiving, so they can invest some time on other tasks and self-care. Social support can also shape experiences of caregivers regarding caregiver burden. Participants with strong social support found strength from social support to have a better quality of life, whereas lack of social support was a source of fatigue for other caregivers. It is interesting to note that the availability and duration of social support was found to be subject to change with the passage of time. There was more support offered to caregivers in the primary stage of caregiving which lessened with time.

The role of support groups was identified as vital for participants to seek informational and emotional social support. These support groups were not always led by health experts/topic experts; however, just having an avenue to voice their experiences and being able to find people having relatable experiences was a source of help and motivation for the caregivers in this study.

Implication for Nursing Practice and Nursing Research

This study will aid nurses to prepare caregivers for transition from inpatient to community settings. Nurses can be a source of informational social support for stroke caregivers. This will prepare the caregivers for anticipated changes and challenges on the caregiving continuum. One of the participants suggested that it would be more helpful for him as a caregiver if he was

provided with a list of ten essential instructions that stroke caregivers might want to explore including joining a support group, and other useful tips and suggestions.

This study opens an avenue for more nursing research on stroke caregiving. A longitudinal study can be planned to measure social support available to stroke caregivers at different time points on the caregiving continuum (one-month, six-months, one-year, and five-years). This will assist researchers to measure effect of time on the social support measure. Nurse researchers can prepare the caregiver for the possibility of losing social support over time. Part of the reason that the social support fades over time is that the caregiver is often forced to forfeit some of their prior social activities and relationships due to their caregiving responsibilities, so those relationships are naturally going to weaken and fade when there is no interaction.

From Pearlin's Stress Theory (Pearlin et al., 1990), a correlational study can be planned to find association between social support (mediator construct) and caregiver outcomes, such as depression and anxiety. This will help to assess the strength of the relationship between two identified concepts from the selected theory. Another study to measure association between caregiver burden or stress scores and caregiver outcomes can be planned to assess if these variables are mediated by social support as a moderating concept. In this way, variables from Pearlin Stress Theory (Pearlin et al., 1990) can be tested for the stroke caregiver population.

A phenomenological study would identify experiences of stroke caregivers and social support available to them in times of COVID-19. Another qualitative study could explore viewpoints of how COVID-19 impacted stroke caregiver support groups. These are some examples of possible future research that could stem from this study.

Summary

To summarize, this chapter provided details on interpretation of themes of this study and examined them considering current literature. Later, study limitations were examined.

Moreover, answers to the identified research questions were illustrated. The investigator analyzed the potential implications of this study for nursing practice and stated some examples for future research.

References

- Abeasi, D. (2020). Depression and quality of life among family caregivers of stroke survivors in Ghana: The role of social support. *Archives of Mental Health, 21*(2), 83-89.
https://www.amhonline.org/temp/ArchMentHealth21283-7360453_202644.pdf
- Akosile, C. O., Banjo, T. O., Okoye, E. C., Ibikunle, P. O., & Odole, A. C. (2018). Informal caregiving burden and perceived social support in an acute stroke care facility. *Health and Quality of Life Outcomes, 16*(57), 1-7. <https://doi.org/10.1186/s12955-018-0885-z>
- Albrecht, D., Wollensak, T., Ernst, C., Becker, C., Hautzinger, M., & Pfeiffer, K. (2016). Costs of informal care in a sample of German geriatric stroke survivors. *European Journal of Ageing, 13*, 49-61. <https://link-springer-com.ezproxy.uta.edu/content/pdf/10.1007/s10433-015-0356-x.pdf>
- American Heart Association. (2018). *Projected costs of informal caregiving for cardiovascular disease: 2015 to 2035*. <https://healthmetrics.heart.org/wp-content/uploads/2018/04/Projected-Costs-of-Informal-Caregiving-for-Cardiovascular-Disease.pdf>
- American Heart Association. (2020). *Heart disease and stroke statistics-2020 update: A report from the American heart association*.
<https://www.ahajournals.org/doi/epub/10.1161/CIR.0000000000000757>
- American Psychological Association. (2021). *Manage stress: Strengthen your support network*.
<https://www.apa.org/topics/manage-stress-social-support>

American Stroke Association. (2020). *Being a stroke family caregiver*. https://www.stroke.org/-/media/stroke-files/lets-talk-about-stroke/caregivers/Its-the-stroke-family-caregiver-ucm_474396.pdf?la=en

American Stroke Association. (2021). *About stroke*.
<https://www.stroke.org/en/about-stroke>

American Stroke Association. (2021). *Family caregivers*. <https://www.stroke.org/en/help-and-support/for-family-caregivers>

American Stroke Association. (2021). *Stroke symptoms*. <https://www.stroke.org/en/about-stroke/stroke-symptoms>

Bolden, L., & Wicks, M. N. (2008). The clinical utility of the stress process model in family caregivers of liver transplant candidates, *Progress in Transplantation*, 18(2), 74-79.
Retrieved from <https://www.ncbi.nlm.nih.gov/pubmed/18615971>

Bosma, M. S., Nijboer, T. C., Caljouw, M. A., & Achterberg, W. P. (2020). Impact of visuospatial neglect post-stroke on daily activities, participation and informal caregiver burden: A systemic review. *Annals of Physical and Rehabilitation Medicine*, 63, 344-358.
<https://reader.elsevier.com/reader/sd/pii/S1877065719300727?token=0BE87F2DE69878EC822AAD02D6149630F9BABA28662EFB15FFDF40FA58E270AAAAEF4980BDB119BCFEDCCC5C2484B0B2&originRegion=us-east-1&originCreation=20210731011855>

- Bradshaw, C., Atkinson, S., & Doody, O. (2017). Employing a qualitative descriptive approach in health care research. *Global Qualitative Nursing Research, 4*, 1-8.
<https://journals.sagepub.com/doi/pdf/10.1177/2333393617742282>
- Brinda, E. M., Rajkumar, A. P., Enemark, U., Attermann, J., & Jacob, K. S. (2014). Cost and burden of informal caregiving of dependent older people in a rural Indian community. *BMC Health Services Research, 14*, 207-215.
<https://bmchealthservres.biomedcentral.com/articles/10.1186/1472-6963-14-207>
- Bucki, B., Spitz, E., & Baunmann, M. (2019). Emotional and social repercussions of stroke on patient-family caregiver dyads: Analysis of diverging attitudes and profiles of the differing dyads. *PLoS ONE, 14*(4), 1-15. <https://doi.org/10.1371/journal.pone.0215425>
- Byun, E., Riegel, B., Sommers, M., Tkacs, N., & Evans, L. (2016). Caregiving immediately after stroke: A study of uncertainty in caregivers of older adults. *American Association of Neuroscience Nurses, 48*(6), 343-351. <https://go-gale-com.ezproxy.uta.edu/ps/i.do?p=HRCA&u=txshracd2597&id=GALE%7CA472988217&v=2.1&it=r&sid=summon>
- Camicia, M., Lutz, B. J., Harvath, T., Kim, K. K., Drake, C., & Joseph, J. G. (2019). Development of an instrument to assess stroke caregivers' readiness for the transition home. *Rehabilitation Nursing, 00*(0), 1-12. doi: 10.1097/rnj.0000000000000204
- Camicia, M., Lutz, B., Markoff, N., & Catlin, A. (2019). Determining the needs of family caregiver of stroke patients during inpatient rehabilitation using interview, art, and survey. *Rehabilitation Nursing, 44*(6), 328-337. doi:10.1097/rnj.0000000000000129

Centers for Disease Control and Prevention. (2020). *Stroke signs and symptoms*.

https://www.cdc.gov/stroke/signs_symptoms.htm

Christensen, E. R., Golder, S. L., & Gesell, S. B. (2019). Perceived benefits of peer support groups for stroke survivors and caregivers in rural North Carolina. *North Carolina Medical Journal, 80*(3), 143-148.

<https://www.ncbi.nlm.nih.gov/pmc/articles/PMC6730634/pdf/nihms-1032886.pdf>

Eagly, A. H., Nater, C., Miller, D. I., Kaufmann, M., & Sczesny, S. (2019). Gender stereotypes have changed: A cross-temporal meta-analysis of U.S. public opinion polls from 1946 to 2018. *American Psychological Association, 1-15*.

<https://www.apa.org/pubs/journals/releases/amp-amp0000494.pdf>

Erler, K. S., Sullivan, V., Mckinnon, S., & Inzana, R. (2019). Social support as a predictor of community participation after stroke. *Frontiers in Neurology, 10*, 1-7.

<https://doi.org/10.3389/fneur.2019.01013>

Fadilah, N., Nursalam, K., & Rahariyani, L. D. (2019). Analysis of influencing factors of burden of caregiver among stroke patients at home. *Journal of Public Health in Africa, 10*(1188), 70-73. <https://publichealthinafrica.org/index.php/jphia/article/view/1188/509>

Fadilah, N., & Rahariyani, L. D. (2019). The impact of independent of activity daily living among stroke patients on caregivers burden. *Jurnal Ners, 14*(3), <https://www.e-journal.unair.ac.id/JNERS/article/view/17047>

Family Caregiver Alliance (2020). *Stroke*. <https://www.caregiver.org/stroke>

- Fei, K. W., Hassan, S. T., Sann, L. M., Ismail, S. I., Raman, R., & Ibrahim, F. (2017). Depression, anxiety and quality of life in stroke survivors and their family caregivers: A pilot study using an actor/partner interdependence model. *Electronic Physician, 9*(8), 4924-4933. <http://dx.doi.org/10.19082/4924>
- Han, Y., Liu, Y., Zhang, X., Tam, W., Mao, J., & Lopez, V. (2017). Chinese family caregivers of stroke survivors: Determinants of caregiving burden within the first six months. *Journal of Clinical Nursing, 26*, 4558-4566. <https://onlinelibrary-wiley-com.ezproxy.uta.edu/doi/epdf/10.1111/jocn.13793>
- Hawken, T., Turner-Cobb, J., & Barnett, J. (2018). Coping and adjustment in caregivers: A systematic review. *Health Psychology, 1-10*.
<https://journals.sagepub.com/doi/pdf/10.1177/2055102918810659>
- Hesamzadeh, A., Dalvadi, A., Maddah, S., B., Khoshknab. M. F., Ahmadi, F., & Arfa, N. M. (2017). Family caregivers' experience of activities of daily living handling in older adult with stroke: A qualitative research in the Iranian context. *Scandinavian Journal of Caring Sciences, 31*, 515-526. <https://onlinelibrary-wiley-com.ezproxy.uta.edu/doi/epdf/10.1111/scs.12365>
- Jamshed, S. (2014). Qualitative research method-interviewing and observation. *Journal of Basic and Clinical Pharmacy, 5*(4), 87-88.
<https://www.ncbi.nlm.nih.gov/pmc/articles/PMC4194943/pdf/JBCP-5-87.pdf>
- John Hopkins. (2021). *Being a caregiver*.
<https://www.hopkinsmedicine.org/health/caregiving/being-a-caregiver>

John Hopkins. (2021). *Social Support Systems*.

https://www.hopkinsmedicine.org/about/community_health/johns-hopkins-bayview/services/called_to_care/social_support_systems.html

Johnson, J. L., Adkins, D., & Chauvin, S. (2020). Qualitative research in pharmacy education: A review of the quality indicators of rigor in qualitative research. *American Journal of Pharmaceutical Education*, 84(1), 138-146.

<https://www.ncbi.nlm.nih.gov/pmc/articles/PMC7055404/pdf/ajpe7120.pdf>

Kamalakannan, S., Venkata, M. G., Prost, A., Natarajan, A., Pant, H., Chitalurri, N., Goenka, S., Kuper, H. (2016). Rehabilitation needs of stroke survivors after discharge from hospital in India. *Archives of Physical Medicine and Rehabilitation*, 97, 1526-1532.

<http://dx.doi.org/10.1016/j.apmr.2016.02.008>

Katbamna, S., Manning, L., Mistri, A., Johnson, M., & Robinson, T. (2017). Balancing satisfaction and stress: Carer burden among white and British Asian Indian carers of stroke survivors. *Ethnicity & Health*, 22(4), 425-441.

<https://dx.doi.org/10.1080/13557858.2016.1244740>.

Kaur, P., Kaur, S., Bhalla, A., Katyal, P., Raavi, Kaur, R., Kaur, R., Bhangu, R. K., & Kaur, R. (2018). *Journal of Perioperative & Critical Intensive Care Nursing*, 4(2), 1-4.

<https://www.longdom.org/open-access/strain-among-the-family-caregivers-of-patients-with-stroke-2471-9870-10000144.pdf>

- Kelly, D. E., Lewis, M. A., Southwell, B. G. (2017). Perceived support from a caregiver's social ties predicts subsequent care-recipient health. *Preventive Medicine Reports*, 8, 108-111. <http://dx.doi.org/10.1016/j.pmedr.2017.08.001>
- Khalaila, R., & Cohen, M. (2016). Emotional suppression, caregiving burden, mastery, coping strategies and mental health in spousal caregivers. *Aging & Mental Health*, 20(9), 908-917. <http://dx.doi.org/10.1080/13607863.2015.1055551>
- Kitamura, T., Adachi, Y., & Uemura, T. (2021). Effect of caregiving on employment for senior workers in Japan. *Ageing International*, 46, 142-169. <https://link-springer-com.ezproxy.uta.edu/content/pdf/10.1007/s12126-020-09377-8.pdf>
- Kokorelias, K. M., Lu, F. K., Santos, J. R., Xu, Y., Leung, R., & Cameron, J. (2020). "Caregiving is a full-time job" impacting stroke caregivers' health and well-being: A qualitative meta-synthesis. *Health and Social Care in the Community*, 28, 325-340. <https://onlinelibrary-wiley-com.ezproxy.uta.edu/doi/epdf/10.1111/hsc.12895>
- Korstjens, I., & Moser, A. (2018). Series: Practical guidance to qualitative research. Part 4: Trustworthiness and publishing. *European Journal of General Practice*, 24(1), 120-124. <https://www.tandfonline.com/doi/pdf/10.1080/13814788.2017.1375092>
- Krishnan, S., Pappadis, M. R., Weller, S. C., Fisher, S. R., Hay, C. C., & Reistetter, T. A. (2018). Patient-centered mobility outcome preferences according to individuals with stroke and caregivers: A qualitative analysis. *Disability and Rehabilitation*, 40(12), 1401-1409. <https://doi.org/10.1080/09638288.2017.1297855>

- Lee, B. W. (2015). *The effects of stress and burden on caregivers of individuals with a chronic illness* [Doctoral dissertation, Walden University]. Retrieved from <https://core.ac.uk/download/pdf/147833592.pdf>
- Leung, D. Y., Chan, H. Y., Chiu, P. K., Lo, R. S., & Lee, L. L. (2020). Source of social support and caregiving self-efficacy on caregiver burden and patient's quality of life: A path analysis on patients with palliative care needs and their caregivers. *International Journal of Environmental Research and Public Health*, *17*, 5457-5470. <https://www.ncbi.nlm.nih.gov/pmc/articles/PMC7432213/pdf/ijerph-17-05457.pdf>
- Liu, H. Y., Yang, C. T., Wang, Y. N., Hsu, W. C., Huang, T. H., Lin, Y. E., Liu, Y. C., & Shyu, Y. L. (2017). Balancing competing needs mediates the association of caregiving demand with caregiver role strain and depressive symptoms of dementia caregivers: A cross-sectional study. *Journal of Advanced Nursing*, *73*, 2962-2972. doi:10.1111/jan.13379
- Llanque, S., Savage, L., Rosenburg, N., & Caserta, M. (2016). Concept analysis: Alzheimer's caregiver stress. *Nursing Forum*, *51*(1), 21-31. doi:10.1111/nuf.12090
- Lutz, B. J., Young, M. E., Creasy, K. R., Eisenbrandt, L., & Cook, C. (2017). Improving stroke caregiver readiness for transition from inpatient rehabilitation to home. *The Gerontologist*, *57*(5), 880-889. <https://doi.org/10.1093/geront/gnw135>
- Menon, B., Salini, P., Habeeba, K., Conjeevaram, J., & Munisusmitha, K. (2017). Female caregivers and stroke severity determines caregiver stress in stroke patients. *Annals of Indian Academy of Neurology*, *20*(4), 418-424. doi:10.4103/aian.AIAN_203_17
- Moon, M. (2017). The unprepared caregiver. *The Gerontologist*, *57*(1), 26-31. doi:10.1093/geront/gnw080

- Mulud, Z. A., & McCarthy, G. (2017). Caregiver burden among caregivers of individuals with severe mental illness: Testing the moderation and mediation models of resilience. *Archives of Psychiatric Nursing, 31*, 24-30. doi:10.1016/j.apnu.2016.07.019
- Munhall, P. L. (2012). *Nursing research: A qualitative perspective* (5th ed.). Sudbury, MA: Jones & Bartlett. ISBN: 978-0-7637-8515-4
- National Alliance for Caregiving and American Association for Retired Persons. (2020). *Caregiving in the U.S. 2020 report*. https://www.caregiving.org/wp-content/uploads/2020/06/AARP1316_RPT_CaregivingintheUS_WEB.pdf
- Palinkas, L. A., Horwitz, S. M., Green, C. A., Wisdom, J. P., Duan, N., & Hoagwood, K. (2015). Purposeful sampling for qualitative data collection and analysis in mixed method implementation research. *Administration and Policy in Mental Health, 42*(5), 533-544. <https://www.ncbi.nlm.nih.gov/pmc/articles/PMC4012002/pdf/nihms-538401.pdf>
- Park, M., Sung, M., Kim, S. K., Kim, S., & Lee, D. Y. (2015). Multidimensional determinants of family caregiver burden in Alzheimer's disease. *International Psychogeriatrics, 27*(8), 1355-1364. doi:10.1017/S1041610215000460
- Pearlin, L., Mullan, J., Semple, S., & Skaff, M. (1990). Caregiving and the stress process: An overview of concepts and their measures. *Gerontologist, 30*(5), 538-594. doi:10.1093/geront/30.5.583
- Pearlin, L. I. (2010). The life course and the stress process: some conceptual comparisons. *Journal of Gerontology: Social Sciences, 65B*(2), 207-215. <https://pubmed.ncbi.nlm.nih.gov/20022925/>

- Penning, M. J., & Wu, Z. (2016). Caregiver stress and mental health: Impact of caregiving relationship and gender. *The Gerontologist*, *56*(6), 1102-1113.
<https://academic.oup.com/gerontologist/article/56/6/1102/2952858?login=true>
- Pesantes, M. A., Brandt, L. R., Ipince, A., Miranda, J. J., & Diez-Canseco. (2017). An exploration into caring for a stroke-survivor in Lima, Peru: Emotional impact, stress factors, coping mechanisms and unmet needs of informal caregivers. *eNeurologicalSci*, *6*, 33-50. <http://dx.doi.org/10.1016/j.ensci.2016.11.004>
- Pino-Casado, R. D., Osuna, A. F., Moral-Palomino, P. A., Ruzafa-Martinez, M., & Ramos-Morcillo, A. J. (2018). Social support and subjective burden in caregivers of adults and older adults: A meta-analysis. *PLoS ONE*, *13*(1), e0189874.
<https://journals.plos.org/plosone/article?id=10.1371/journal.pone.0189874>
- Pitthayapong, S., Thiangtam, W., Powwattana, A., Leelacharas, S., & Water, C. M. (2017). A community based program for family caregivers for post stroke survivors in Thailand. *Asian Nursing Research*, *11*, 150-157. <http://dx.doi.org/10.1016/j.anr.2017.05.009>
- Polit, D. F., & Beck, C. T. (2017). *Nursing Research: Generating and Assessing Evidence for Nursing Practice* (11th ed.). Wolters Kluwer.
- Ramazan, S., Loke, A. Y., & Chiang, V. C. (2020). Couples coping in the community after the stroke of a spouse: A scoping review. *Nursing Open*, *7*, 472-482.
<https://onlinelibrary.wiley.com/doi/epdf/10.1002/nop2.413>
- Rodriguez-Perez, M., & Abreu-Sanchez, A., Rojas-Ocana, M. J., & Del-Pino-Casada, R. (2017). Coping strategies and quality of life in caregivers of dependent elderly relatives. *Health*

and *Quality of Life Outcomes*, 15(71), 1-8.

https://www.ncbi.nlm.nih.gov/pmc/articles/PMC5391554/pdf/12955_2017_Article_634.pdf

Sato, A., Fujita, T., & Yamamoto, Y. (2017). Activities of daily living independence level for home discharge in stroke patients based on number of caregivers: An analysis of the Japan rehabilitation database. *Physical Therapy Research*, 20, 23-27.

<https://www.ncbi.nlm.nih.gov/pmc/articles/PMC5743428/pdf/ptr-20-0023.pdf>

Schoenmakers, E. C., Tilburg, T. G., & Fokkema, T. (2015). Problem-focused and emotion-focused coping options and loneliness. *European Journal of Ageing*, 12, 153-161.

https://www.ncbi.nlm.nih.gov/pmc/articles/PMC5549139/pdf/10433_2015_Article_336.pdf

Schwertfeger, J. L., Thuente, L., Hung, P., & Larson, S. L. (2020). Post-discharge interventions to enhance coping skills for survivors of stroke and their caregivers: A scoping review protocol. *JBI Evidence Synthesis*, 18(2), 332-340. doi:10.11124/JPISR-D-18-00024

Sharma, N., Chakrabarti, S., & Grover, S. (2016). Gender differences in caregiving among family- caregivers of people with mental illnesses. *World Journal of Psychiatry*, 6(1), 7-17. <https://www.ncbi.nlm.nih.gov/pmc/articles/PMC4804270/pdf/WJP-6-7.pdf>

Shiba, K., Kondo, N., Kondo, K. (2016). Informal and formal social support and caregiver burden: The ages caregiver survey. *Journal of Epidemiology*, 26(12), 622-628.

<https://www.ncbi.nlm.nih.gov/pmc/articles/PMC5121430/pdf/je-26-622.pdf>

- Skolarus, L. E., Freedman, V. A., Feng, C., Wing, J. J., & Burke, J. F. (2016). Care received by elderly US stroke survivors may be underestimated. *Stroke*, *47*(8), 2090-2095.
doi:10.1161/STROKEAHA.116.012704
- Sutter-Leve, R., Passint, E., Ness, D., & Rindflesch, A. (2021). The caregiver experience after stroke in a COVID-19 environment: A qualitative study in inpatient rehabilitation. *Journal of Neurologic Physical Therapy*, *45*, 14-20.
<https://www.ncbi.nlm.nih.gov/pmc/articles/PMC7737698/pdf/jnpt-45-14.pdf>
- Swinkels, J., Tilburg, T. V., Verbakel, E., & Groenou, M. B. (2019). Explaining the gender gap in the caregiving burden of partner caregivers. *The Journals of Gerontology*, *74*(2), 309-317.
<https://academic.oup.com/psychsocgerontology/article/74/2/309/3097902?login=true>
- Tosun, Z. K., & Temel, M. (2017). Burden of caregiving for stroke patients and the role of social support among family members: An assessment through home visits. *International Journal of Caring Science*, *10*(3), 1696-1704. <https://web-b-eb-sco-host-com.ezproxy.uta.edu/ehost/pdfviewer/pdfviewer?vid=1&sid=19a05125-ccae-4dd7-95a8-b1c8132581f4%40sessionmgr103>
- Uccheddu, D., Gauthier, A. H., Steverink, N., Emery, T. (2019). The pains and reliefs of the transitions into and out of spousal caregiving. A cross-national comparison of the health consequences of caregiving by gender. *Social Science & Medicine*, *112517*, 1-9.
<https://reader.elsevier.com/reader/sd/pii/S0277953619305118?token=F841D13879EB6035006D760C5DE183EE8E3B249E3877E4434330A457C7E34BFCF5C55D9C9C7FE7FBEO6DCD254F05EF97&originRegion=us-east-1&originCreation=20210730212040>

University of California, San Francisco. (2014). *In memoriam: Leonard I. Pearlin, PhD.*

<https://psychiatry.ucsf.edu/news/memorial-leonard-i-perlin-phd>

University of Pennsylvania. (n.d.). *Social Support*. <https://www.med.upenn.edu/hbhe4/part3-ch9-key-constructs-social-support.shtml>

Wang, L. J., Zhong, W. X., Ji, X. D., & Chen, J. (2016). Depression, caregiver burden and social support among caregivers of retinoblastoma patients in China. *International Journal of Nursing Practice*, 22, 478-485. <https://onlinelibrary-wiley-com.ezproxy.uta.edu/doi/epdf/10.1111/ijn.12458>

Woodford, J., Farrand, P., Watkins, E. R., Llewellyn, D. J. (2018). "I don't believe in leading a life of my own, I lead his life: A qualitative investigation of difficulties experienced by informal caregivers of stroke survivors experiencing depressive and anxious symptoms. *Clinical Gerontologist*, 41(4), 293-307.

<https://content.ebscohost.com/ContentServer.asp?T=P&P=AN&K=129510580&S=R&D=ccm&EbscoContent=dGJyMNHr7ESep7U4yNfsOLCmsEmep7ZSrqa4TLeWxWXS&ContentCustomer=dGJyMPGuslGvqrdKuePfgeyx44Dt6fIA>

Wu, X., Liang, Y., Zheng, B., Wang, H., Ning, M., Zheng, H., & Shi, B. (2020). Care stress in caregivers of disabled stroke patients: A cross-sectional survey. *Annals of Palliative Medicine*, 9(4), 2211-2220. <http://dx.doi.org/10.21037/apm-20-1369>

Xiong C., Biscardi, M., Astell, A., Nalder E., Cameron, J. I., Mihailidis, A., & Colantonio, A. (2020). Sex and gender differences in caregiving burden experienced by family

- caregivers of persons with dementia: A systemic review. *PLoS ONE*, *15*(4), 1-22.
<https://doi.org/10.1371/journal.pone.0231848>
- Yang, Z., Tian, Y., Fan, Y., Liu, L., Luo, Y., Zhou, L., & Yu, H. (2019). The mediating roles of caregiver social support and self-efficacy on caregiver burden in Parkinson's disease. *Journal of Affective Disorders*, *256*, 302-308. <https://doi.org/10.1016/j.jad.2019.05.064>
- Ye, F. (2016). Experiences of stress and coping over time by caregivers of stroke survivors: A mixed-methods approach [doctoral dissertation, The University of Texas Health Science Center at Houston].
https://digitalcommons.library.tmc.edu/cgi/viewcontent.cgi?article=1020&context=uthson_etd
- Yu, Y., Zhou, W., Liu, Z. W., Hu, M., Tan, Z. H., Xia, S. Y. (2019). Gender differences in caregiving among a schizophrenia population. *Psychology Research and Behavior Management*, *12*, 7-13. <https://www.ncbi.nlm.nih.gov/pmc/articles/PMC6304241/pdf/prbm-12-007.pdf>
- Zawawi, N. S., Aziz, N. A., Fisher, R., Ahmad, K., & Walker, M. F. (2020). The unmet needs of stroke survivors and stroke caregivers: A systemic narrative review. *Journal of Stroke and Cerebrovascular Diseases*, *29*(8), 1-14.
<https://doi.org/10.1016/j.jstrokecerebrovasdis.2020.104875>
- Zhong, Y., Wang, J., & Nicholas, S. (2020). Social support and depressive symptoms among family caregivers of older people with disabilities in four provinces of urban China: the

mediating role of caregiver burden. *BMC Geriatrics*, 20(3), 1-10.

<https://bmcgeriatr.biomedcentral.com/articles/10.1186/s12877-019-1403-9>

Zur, H. B. (2017). *Emotion-focused coping*. *Encyclopedia of personality and individual differences*. https://link.springer.com/referenceworkentry/10.1007%2F978-3-319-28099-8_512-1

Appendix A

Script for Recruitment or Invitation Script

Hello everyone,

My name is Zara Sajwani. I am Ph.D. Nursing student at the University of Texas at Arlington. In my research project, I am studying experiences of informal stroke caregivers. This research will help us understand how caregivers cope with stress and use their social support.

If you are caring for/have cared for stroke victim, you can participate in this study. All you need to do is answer the questions I will ask you in an interview. After you have participated, a gift card will be mailed to you.

If you are interested in participating please share your name and phone number with me, and I will contact you individually.

(Interested subjects' name and phone number will be obtained to establish contact. Name and phone number will not be used as data. This information is only obtained to approach them for further data collection proceedings).

Appendix B
Flyer

**Attention Family and Friends
of Stroke Victims!!!**

You are invited to participate in a research
study on Caregiving of Stroke Victims.

**YOUR PARTICIPATION IS
VALUED!!!**

**YOU WILL BE COMPENSATED
FOR THE TIME YOU SPEND IN
THIS INTERVIEW**

This research is the dissertation project of a PhD Nursing
student. Dr. Kathryn Daniel from the University of Texas
Arlington is serving as Dissertation Chair

If you would be willing to participate in an
interview with the investigator, please call Zara
Sajwani at 469-664-8342 or email
zara.sajwani@mavs.uta.edu

Appendix C

Screening Script

Hello,

My name is Zara Sajwani. I am a doctoral student in nursing at the University of Texas at Arlington (UTA). My dissertation chair is Dr. Kathryn Daniel from UTA. As my school dissertation, I am focusing on informal stroke caregiving. Informal caregiving means voluntary and free care and support provided to patients by their friends, relatives, etc. Caring for a stroke victim can be difficult for informal caregivers. Therefore, the role of social support from other family members and friends available to the stroke caregivers is very important. I am interviewing informal stroke caregivers to define the impact of social support they get from their friends and family when caring for a stroke victim. This study will help us understand the challenges you are facing, ways you are coping, and the support you are receiving from your social network in fulfilling your role as a stroke caregiver. Results from this study can add to the available knowledge on stroke caregiving. Future measures and facilities can be planned to help the stroke caregiver population.

If you volunteer to participate, we will decide a time to conduct your interview at the end of this call. You can stop participating in the study at any time. The time you will have will be utilized to seek answers for some demographic questions which will take about five minutes and the interview is expected to last from 30 to 90 mins. To thank you for your time, a gift card of \$10 will be provided to you after the interview.

All measures will be taken to guard your identity. If this research is shared for professional and scholarly reasons or if this research is published, your private information will be removed to maintain confidentiality.

Are you interested to be part of this research?

Eligibility criteria questions

If you have any questions about this study, please feel free to reach out to Zara Sajwani at 469-664-8342 or zara.sajwani@mavs.uta.edu OR Dr. Kathryn Daniel at 817-272-7344 or kdaniel@uta.edu

Appendix D

Script for Verbal Consent

Greetings,

This is Zara Sajwani. I am a PhD nursing student at the University of Texas at Arlington. As part of my school doctoral dissertation, I am conducting a study to explore how social support influences the experiences of informal stroke caregivers. It is significant to understand the support of your friends and family members available to you while you care/cared for stroke victim. This study can be helpful to support interventions to meet the needs of informal caregivers.

It is voluntary to participate in this research. If you agree to participate, few demographic questions will be asked, and an interview will be conducted for 30 mins to 90 mins on phone with you. You can stop participating in the study at any time without any impact of the care/services you may be receiving. If any question makes you feel uncomfortable, you can skip that question without any hesitation. As token of gratitude to participate in this study, you will be given a \$10 gift card after the interview.

Audio recording of the data collection will be done. Only research team can approach data. The recording will be deleted after transcribing the data. If this study is shared with others for academic, scholarly, and professional purposes and if it is published, all personal identifiers are erased. All efforts will be made to protect your privacy.

There may not be material benefit to you by participating in this study. Also, there is no anticipated harm to you by participating in this study other than what you would typically encounter in your routine.

If you have any questions, please share now.

For any concerns or questions, kindly contact me at 469-664-8342 or email at zara.sajwani@mavs.uta.edu. Or contact Dr. Kathryn Daniel at 817-272-7344 or kdaniel@uta.edu

Please do not hesitate to reach out to regulatory services at 817-272-3723 or regulatoryservices@uta.edu for any inquiries related to your rights or concerns related to this study.

If you agree to voluntarily participate in this study, we can begin the interview.

Refer Appendix E
Data Collection Tools
Demographic Tool

Caregiver's:

Sex

Age

Ethnicity

Marital status

Relation to stroke victim

Time elapsed since stroke

Education level: less than college/ college graduate/skills training/ undergraduate/professional degree or graduate level or above.

Number of people living in the household:

Living with care recipient: Yes/No

Working? Y/N

What services are patients with stroke currently receiving or received? Hired help/outpatient/home health/ day neuro/ others (please specify)

Interview Guide

- 1- In your perception, how bad was the stroke of your loved one?
 - Affected cognition (ability to think)?
 - Affected mobility (ability to move)?
 - Affected communication?
 - Patient unable to perform roles and responsibilities
- 2- Please share your experiences on how has stroke of your loved one affected your life.

Probes:

 - Roles and responsibilities
 - Routine before stroke and after stroke
 - Would the person you care for (recipient of care; stroke survivor) agree with your answers or disagree?
 - Is that a big source of stress if the stroke survivor is very demanding and does not realize the impact on you.
- 3- When you are in stress, how do you cope?

Probes:

 - Television, friends, religion, problem solving, professional help, exercise, relax, meditation, etc.
 - Any other way use for coping?
 - How has this way of coping helped you?
- 4- Please share your experiences on how are you coping with the change in your roles and responsibilities caused by stroke of your loved one?
- 5- What is your support system at home to help you cope with caregiving responsibilities?

Probes:

 - Support from another family caregiver

- How has that helped you?
- 6- What is the role of your family and friends in helping you with managing care of your loved one with stroke?
- Probes:
- ADLs, IADLs, care coordination
 - Other responsibilities: babysitting, manage work hours
- 7- If you are busy or not around, how do you manage the care of your loved one?
- 8- Please share your recent experience when your family/friends made you feel loved and valued?
- Probes:
- Looked after your needs
 - Made you feel valued on your special day
 - Spoke with you if you needed them any time of the day
 - Helped you without incentive
 - Checked on you to ensure your wellbeing
 - Offered help and support
 - Helped you on an eventful day
- 9- What is the role of your social network in solving your issues?
- Probes:
- Process of problem solving
 - Who helped? How helped? How it made you feel?
 - Do you feel welcomed/ comfortable to seek their support?
 - Example
 - Suggestions/ Ventilation/Relief/ Analysis of issue/Solve problem for you
 - Your understanding level with your support system (family/friends)
- 10- What is your recent experience of having an interaction or spending good time with your family/friend(s)?
- Probes:
- Who approached first or initiated the interaction?
 - Reason of interaction? Topic of discussion?
 - How it made you feel?
 - Why do you look forward to such interactions?
 - How frequently do you have such interactions?
 - What prevents you from it? (privacy, time limitation, etc.)
- 11- Anything you wish was better related to your social support?
- 12- Any additional comments and experiences would you like to share?

Refer Appendix G
UTA IRB Approval Letter



UNIVERSITY OF
TEXAS
 ARLINGTON

OFFICE OF RESEARCH ADMINISTRATION
 REGULATORY SERVICES

6/10/2021

IRB Approval of Minimal Risk (MR) Protocol

PI: Zara Sajwani

Faculty Advisor: Kathryn Daniel

Department: Nursing - Graduate

IRB Protocol #: [REDACTED]

Study Title: *Perceptions and Experiences of Informal Caregivers Related to the Role of Social Support while Caring for Stroke Victims*

Effective Approval: 6/10/2021

The IRB has approved the above referenced submission in accordance with applicable regulations and/or UTA's IRB Standard Operating Procedures.

Principal Investigator and Faculty Advisor Responsibilities

All personnel conducting human subject research must comply with UTA's IRB Standard Operating Procedures and RA-PO4, Statement of Principles and Policies Regarding Human Subjects in Research. Important items for PIs and Faculty Advisors are as follows:

- ****Notify Regulatory Services of proposed, new, or changing funding source****
- Fulfill research oversight responsibilities, IV.F and IV.G.
- Obtain approval prior to initiating changes in research or personnel, IX.B.
- Report Serious Adverse Events (SAEs) and Unanticipated Problems (UPs), IX.C.
- Fulfill Continuing Review requirements, if applicable, IX.A.
- Protect human subject data (XV.) and maintain records (XXI.C.).
- Maintain HSP (3 years), GCP (3 years), and RCR (4 years) training as applicable.

REGULATORY SERVICES

The University of Texas at Arlington, Center for Innovation
 202 E. Border Street, Suite 300, Arlington, Texas 76010, Box #19188
 (Phone) 817-272-3723 (Email) regulatoryservices@uta.edu (Web) www.uta.edu/rs