

EXPERIMENTAL STUDY OF DYNAMIC COOLING OF RACKS
USING FLOW CONTROL DEVICES

By

AKASH FNU

Presented to the Faculty of the Graduate School of
The University of Texas at Arlington in Partial Fulfillment
of the Requirements
for the Degree of

MASTER OF SCIENCE IN AEROSPACE ENGINEERING

THE UNIVERSITY OF TEXAS AT ARLINGTON

MAY 2020

ACKNOWLEDGEMENTS

Firstly, I would like to express my gratitude to my advisor Dr. Dereje Agonafer, for his constant support throughout the journey of my thesis. I would like to thank him for his patience and encouragement. I wish to thank Dr. Agonafer for allowing me to use his lab for experimental and research work and letting me use the necessary equipment to aid my research. In addition, I would also like to thank Dr. Agonafer for personally guiding me through all this.

Secondly, I would like to convey my gratitude towards Dr. Amaya and Dr. Haji-Sheikh for agreeing to be in my defense committee panel. I would like to thank Mr. Pardeep Shahi, Mr. Satyam Saini and Mr. Pratik Bansode for the guidance throughout the course of my thesis with thermal and mechanical aspects. I am thankful to Mr. Amirreza Niazmand for helping me with the experimental setup at various stages. I am also grateful for the help and support from various students in Dr. Agonafer's lab. I would also like to thank Mr. Winfrey Rex for help and support in 3D printing of the required components of the experimental setup. I am grateful to Mr. Kermit Beird for providing valuable advice regarding various mechanical aspects of the setup and for helping me build various components. I would like to thank the staff at the department of Mechanical and Aerospace Engineering at University of Texas at Arlington for the help through various steps through my Thesis. I am grateful to Dr. Kamesh Subbarao for being a valuable graduate advisor and for guiding me through all the process. I would like to convey my special thanks to all my colleagues for their help throughout my Thesis.

Finally, I would like to convey my sincere gratitude to my parents Mr. Niranjan Belle and Mrs. Jayashree Rao and my sister Madhura Belle who supported me and guided me throughout my life and made me the man I am today. I would also like to show my appreciation towards all my friends who have helped me with different aspects while I was away from home.

June 05, 2020

ABSTRACT

DYNAMIC COOLING OF RACKS USING FLOW CONTROL DEVICES AND ITS EXPERIMENTAL VALIDATION

Akash FNU, M.S.

The University of Texas at Arlington, 2020

Supervising Professor: Dr. Dereje Agonafer

A data center is a cluster of multiple servers that a company uses to store and process large amounts of data. Due to never-ending demands, the processor densities are increasing every day. A higher processor density would result in the servers heating up more than it would normally creating a need for an efficient cooling system. On an average a water-cooled system would consume up to 40% of the total power required by a data center. Studies are being conducted on improving the overall efficiency of the system by either improving the thermal properties of the system or by improving the pumping efficiency. This study explores a way of improving the efficiency by saving pumping power. Practically looking at the situation, not every server is going to be used at all times. The loads would vary depending on the process where one would need the computing power of the whole rack in which case the system would need to be cooled equally but a different process would only engage 2 servers out of the available ones in the rack. In this scenario these two racks would consume more power in turn dissipating more heat compared to the others. This gives us room to vary the flow rate and introduce dynamic cooling to save pumping power.

This study concentrates on a control strategy using a flow control device that is used to vary the flow rate individually on different levels based on the temperature of the coolant. The variation of flow rates is directly going to be related to the savings in pumping power. Variations in temperature, pressure and flow

rate is observed at different intervals and the setup is built with these parameters in focus. Two strategies are developed to observe the effect of dynamic cooling, pressure based and temperature based. The results of this experiment will prove the efficiency of dynamic cooling.

TABLE OF CONTENTS

ACKNOWLEDGEMENTS.....	ii
ABSTRACT	iii
LIST OF FIGURES.....	vi
Chapter 1: INTRODUCTION.....	1
Chapter 2: LITERATURE REVIEW	5
2.1 FCD TESTING	5
2.2 CFD ANALYSIS.....	6
Chapter 3: DYNAMIC LIQUID COOLING	8
3.1 FLOW CONTROL DEVICE	8
Chapter 4: EXPERIMENTAL SETUP	11
4.1 PRESSURE-BASED CONTROL STRATEGY	11
4.2 TEMPERATURE-BASED CONTROL STRATEGY	12
Chapter 5: COMPONENTS.....	13
5.1 CERAMIC HEATERS.....	14
5.2 PRESSURE TRANSDUCERS	15
5.3 THERMOCOUPLES	16
5.4 FLOW RATE SENSORS.....	18
5.5 PUMP	19
5.6 DATA ACQUISITION UNIT	19
Chapter 6: LabVIEW INTEGRATION	21
6.1 SENSOR INTEGRATION	21
6.2 ARDUINO INTEGRATION	23
Chapter 7: RESULTS	27
Chapter 8: CONCLUSION.....	28
REFERENCES.....	29
BIOGRAPHICAL INFORMATION.....	31

LIST OF FIGURES

FIGURE 1 HIGH DENSITY FACEBOOK DATA CENTER	3
FIGURE 2 HYSTERESIS CURVE	6
FIGURE 3 SIMULATION RESULTS.....	7
FIGURE 4 SIMULATION SETUP	7
FIGURE 5 POWER SAVING RESULTS.....	7
FIGURE 6 FLOW CONTROL DEVICE	9
FIGURE 7 FCD BEHAVIOR	10
FIGURE 8 EXPERIMENTAL SETUP SCHEMATIC	11
FIGURE 9 SERVER REPLICATION SCHEMATIC.....	14
FIGURE 10 CERAMIC HEATER WIRING SCHEMATIC	15
FIGURE 11 HEATER CLUSTER	15
FIGURE 12 PRESSURE TRANSDUCER.....	15
FIGURE 13 PRESSURE SENSOR WIRING SCHEMATIC	16
FIGURE 14 K-TYPE THERMOCOUPLE.....	16
FIGURE 15 T-TYPE THERMOCOUPLE.....	17
FIGURE 16 THERMOCOUPLE WIRING SCHEMATIC	17
FIGURE 17 OMEGA FLOW SENSOR	18
FIGURE 18 FLOW SENSOR WIRING SCHEMATIC	18
FIGURE 19 PUMP	19
FIGURE 20 INBUILT PWM PORT.....	19
FIGURE 21 SENSOR DATA COLLECTION CODE	22
FIGURE 22 SENSOR DATA COLLECTION FRONT PANEL.....	23
FIGURE 23 PUMP PWM INTEGRATION CODE.....	24
FIGURE 24 ARDUINO FOR HEATERS.....	24

FIGURE 25 SWITCH TO CONTROL HEATER.....	24
FIGURE 26 HEATER PWM CODE.....	25
FIGURE 27 HEATER DUTY CYCLE VARIATION PANEL.....	26
FIGURE 28 EXPERIMENTAL RESULTS	27

Chapter 1: INTRODUCTION

The Internet is evolving at a pace that in a few years everything will need digitization and storing information on a local medium will be so obsolete and unwanted that the need for data centers will rise at a critical rate. When this happens, the amount of power consumed by such large-scale data centers will leave a mark on a global scale. To help combat this problem, dynamic cooling provides a long-term solution.

Typically, an enterprise-class data center consists of more than 100,000 servers with a facility size of more than 5000 sq.ft. and can consume a total power anywhere between 1-500 MW [1]. On a national basis, data centers account for about 2% of the total electricity consumption across the United States [2,3]. Out of this percentage, the cooling energy consumption costs to accounts for 30-50% of the total IT power consumed in a typical data center [4]. Most data centers are traditionally air-cooled which has its own disadvantages like low heat carrying capacity, adding to energy consumption because of the chillers and compressors, hot spot formation, issues associated with aisle containment, etc. Liquid cooling addresses these critical issues related to traditional air cooling of servers due to its ability to absorb higher thermal masses and lower coolant transport energy requirements. These cooling methods use water in dielectric form or other commercially used dielectric refrigerants as a cooling medium running through cold plates or rear door heat exchangers and demonstrate the benefits of data center liquid cooling strategy [5, 6]. Water can improve cooling efficiency and yield further cost savings using higher inlet fluid temperatures and utilizing waste heat for relevant applications within the facility [7]. Copper cold plates have been long used as a method of cooling to high powered devices in a similar way as the Thermal Conduction Module (TCM) [8]. Further, moving the cooling source closer to the heat-generating component helps to reduce the hot spots within the data center white space, thereby, improving the cooling effectiveness. ASHRAE TC 9.9 [9] provides ample data to design guidelines, codes, and standards for implementing water-cooled data centers and mission-critical environments. Since the use of liquid cooling at the server and rack level is being adopted widely for High-Performance Computing applications, the committee has introduced liquid cooling classes as well with varying coolant temperature

ranges. These temperature ranges of the facility supply-side water are defined based on the type of infrastructure cooling design that is to be used [10].

The irregularity in the power consumption of servers gives us a window to implement dynamic cooling. The cooling needs of servers in racks will vary according to the processing load applied on them. A data center will have hundreds of racks and thousands of servers. A minor improvement in cooling efficiency of a single rack will have a significant impact on the overall power consumption of the data center. There are multiple cooling techniques that can be implemented like Air Cooling, Liquid Cooling and Immersion Cooling. Air Cooling is where a fan forces air through the servers or fins attached to the server that help in bringing the junction temperature to an optimum value. Immersion Cooling is where a dielectric fluid is used to immerse the servers inducing direct contact to ensure even and maximum dissipation of heat. Liquid Cooling is where a coolant is forced through a cold plate which is in contact with the server creating an indirect form of heat dissipation. This experimental study focuses on dynamic liquid cooling. Since the processor densities are increasing to meet the needs, the heat flux increases in these servers which are built to have improved computational capabilities. Air cooling no longer can efficiently dissipate the heat produced by these servers. Immersion cooling while being highly effective, it always runs the risk of electrical short circuit in case the fluid is not properly de-ionized.



Figure 1 High Density Facebook Data Center

Liquid Cooling can be quite effective provided that the pumping power is regulated dynamically. Since the fluid needs to be pumped into the cooling loop of the racks, this alone needs a significant amount of power. Liquid cooling systems are responsible for drawing close to 40% of the total power consumed by a data center. This would be the current scenario. This number can be reduced to a great extent if dynamic cooling can be implemented in data centers.

There are a few challenges that are faced when it comes to dynamic cooling. The first is determining the flow rate of the coolant that is needed in different servers. The second would be how to vary the flow rate according to the need of each server. The third would be varying the flow rate to maintain an optimum junction temperature. Fourth would be maintaining the optimum pressure drop across the rack at all times.

The first issue of detecting the server needs are met using a Flow Control Device (FCD). The FCD would block a certain amount of flow creating a pressure drop. A higher pressure drop would indicate that the flow rate is higher than what is needed by the server. The second issue can also be tackled partly

using the FCD as it blocks incoming flow causing it to slow down up to an extent. The flow rate can be varied completely through the pump. In order to determine the optimum flow rate, the pressure drop across the FCD can be monitored and maintained as the temperature varies. Maintaining an optimum pressure drop across the entire rack can be done by PWM Control of the Pump using LabVIEW.

All the above-mentioned issues were faced and resolved while the experiment was being setup. The study aims at optimizing the process of dynamic cooling through the variation of different parameters. Additionally, the experimental setup will act as a basis for future experiments on Flow Control Devices and Dynamic Cooling.

Chapter 2: LITERATURE REVIEW

Previously, simulations were run on 6Sigma ET on a four-server rack with a damper resembling a Flow Control Device. A CFD analysis on the control strategy of this concept was conducted. There were two different control strategies involved. The first one was pressure based where the pressure drop across a rack was observed and maintained at an optimum value in order to achieve dynamic liquid cooling. The second one was based on temperature where the server cold plate outlet temperature is observed and the flow rate is varied according to it through PWM control of the pump. Here the inlet temperature is constant, but according to the varying outlet temperature the flow rate of the server can be varied making the cooling loop more efficient.

2.1 FCD TESTING

In order to determine the functionality and behavior of the Flow Control Device, tests had to be conducted to get a better understanding of how the FCD should function when parameters are varied. A Flow Control Device's basic function is to obstruct oncoming flow causing a change in flow rate across the FCD. The change in flow rate results in change in pressure as well. Once the FCD was designed, it was experimentally tested and a hysteresis curve was developed for the same. Additionally, a grid sensitivity analysis was conducted to study the response of the FCD. The data obtained from these experiments conducted on the FCD was integrated into the damper that would later be used in the CFD analysis of the control strategies on 6Sigma ET.

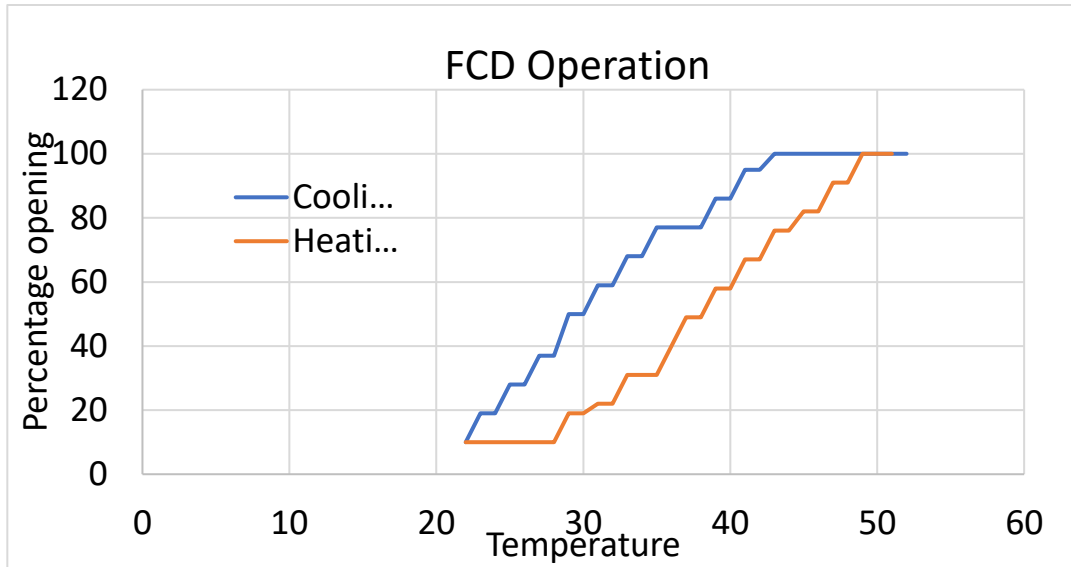

Figure 2 Hysteresis Curve

The graph above is the hysteresis curve obtained by the experimental testing [21]. These values were determined to be the most ideal response that an FCD could give for this particular setup. All of the factors were checked and determined after thorough testing. From the graph, we determine that the experimental setup will need a temperature range between 20°C – 50°C as that is where the maximum variation in the FCD occurs.

2.2 CFD ANALYSIS

Computational Analyses were conducted to determine the effectiveness of dynamic cooling using Flow Control Devices. Based on the experimental results that were obtained from testing the FCD, a damper was used in the simulations to emulate the FCD functions. The simulation was conducted on a four-server setup using 6Sigma ET. The setup contained pressure sensors, temperature sensors and flow sensors similar to the experimental setup that was designed. The cold plates used in the simulations were also taken from CoolIT which is the company that manufactured the cold plates for the experiment. The pipes were made just using an inbuilt function. Additionally, to control the damper, MATLAB was integrated into 6Sigma ET. The four-server setup was similar on each rack and it also included a PWM controllable pump. This setup was designed in a way that parameters could be monitored at points of interest.

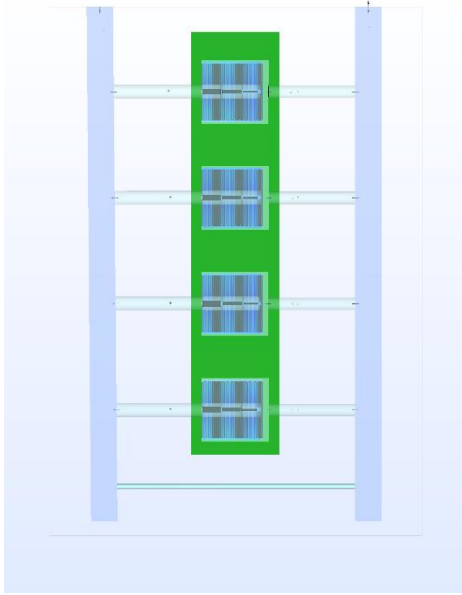

Figure 4 Simulation Setup

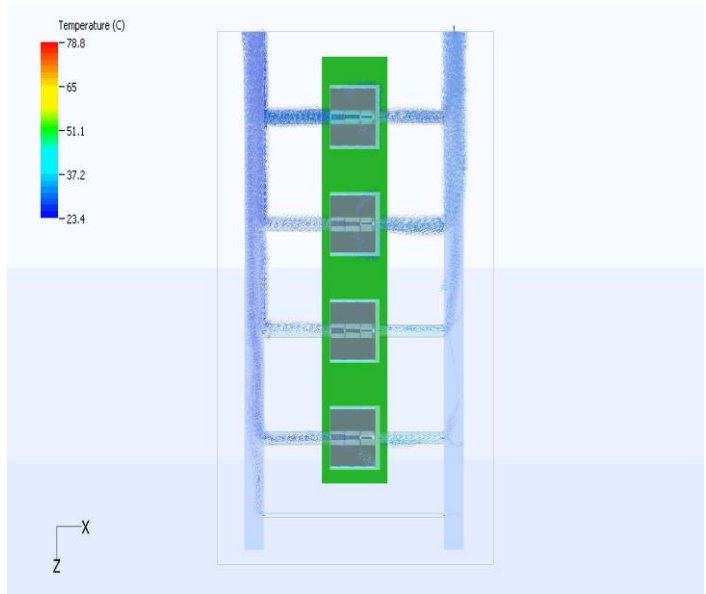

Figure 3 Simulation Results

ASHRAE water standard envelope W2 was used for this study [22]. To observe and compare the results, the Power Usage Effectiveness (PUE) metric was used. After running multiple iterations of the simulations with varying heat flux and pumping power, it was observed that effectively, 64% of pumping power could be saved if dynamic cooling and FCDs were used.

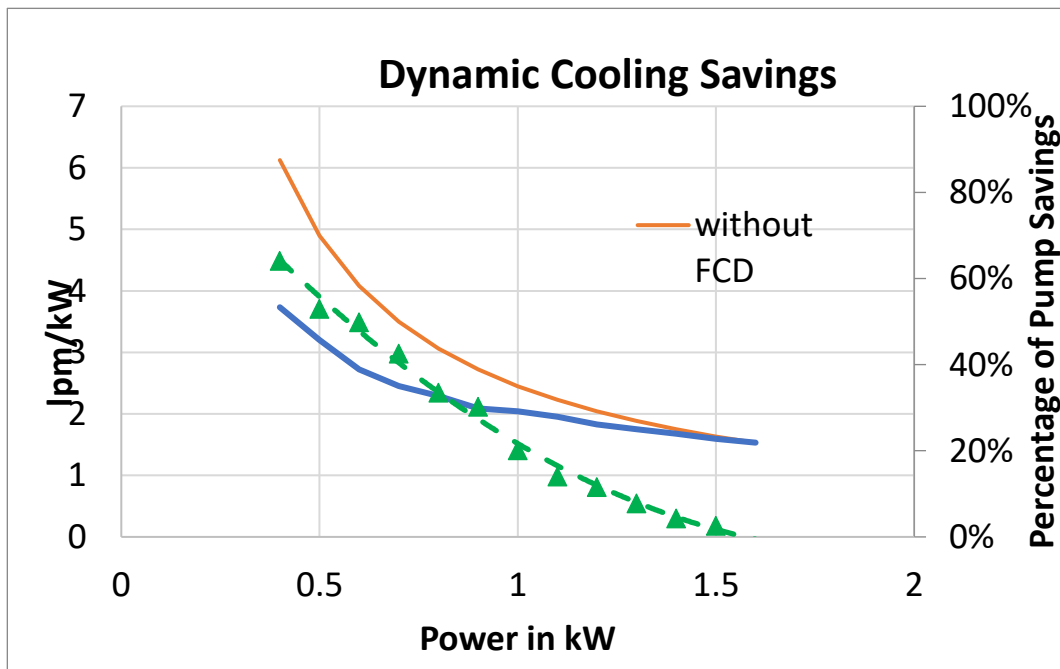

Figure 5 Power Saving Results

Chapter 3: DYNAMIC LIQUID COOLING

Liquid Cooling is when a coolant is passed through a device such as a Cold plate or a Vapor Chamber in order to extract heat from the source at a controlled rate. The setup would generally include a reservoir, a pump and a loop to feed the coolant onto different servers in the racks of a data center. Today, close to 40% of the total power used by a data center is used by the cooling systems. In situations where a couple of racks are idling out of redundancy and a couple are operating at a 100%, the cooling needs of these racks are going to be vastly different, making the current cooling trends highly inefficient. With dynamic cooling we can regulate the flow rate on a server level which can be correlated to pumping power savings.

The concept of dynamic cooling needs an efficient strategy in order to reap maximum benefits. In our study, we have pressure-based control strategy and temperature-based control strategy. This strategy will be discussed in detail in the next chapter. In order to execute dynamic cooling, the Flow Control Device would play a major role in determining the volumetric flow rate of the coolant. In the experimental setup that was built and the setup used in the simulation, the Flow Control Device was placed at the outlet of each server.

3.1 FLOW CONTROL DEVICE

The main function of a Flow Control Device, as the title suggests, is to regulate the flow rate. In this study, it is used to vary the flow rate of the coolant based on its temperature [21]. As mentioned in the literature review, the FCD was designed keeping the ASRAE envelope for direct liquid cooling. The FCD is functional between the temperatures of 20°C and 50°C. The design and development of the FCD was done after rigorous testing and the final product was manufactured after determining its highest efficiency in this envelope.

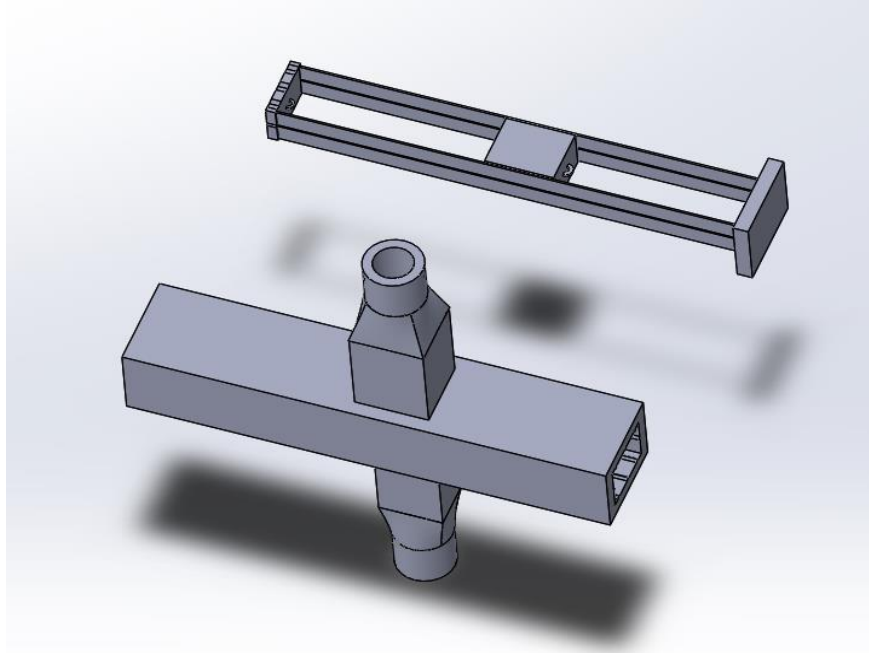

Figure 6 Flow Control Device

The design of the FCD was experimentally tested with different stiffness of springs and different lengths of springs. The image shows a functional Flow Control Device that was used in the experimental setup. The inlet is on the right and the outlet is on the left. The inlet was designed to be slightly larger than the outlet for two reasons, the first one was to be able to distinguish between the inlet and the outlet and the second is due to the positioning of the block as seen in the figure. The central block is attached to springs on either side. On the left is a Stainless-Steel spring with a constant spring stiffness and on the right, we have a Nitinol spring. Nitinol is a smart material comprising of Nickel and Titanium in almost equal parts. The Nitinol spring is temperature activated. So, as the temperature of the spring increases, the stiffness of the spring tends to increase and as a result ends up contracting causing the block to move away from the inlet creating a wider opening with lesser resistance to the flow. The inlet and outlet are shaped circular towards the outside while they smoothly transition to a square at the central chamber. The entire assembly is 3D printed according to the design specifications that is needed. After the springs are attached to the central block and the housing, the Flow Control Device is assembled and sealed off using a water-resistant adhesive to avoid all leakages. The central regulating block should be visible from the outlet and the inlet with a small gap. This indicates that the FCD is in its initial position. Since the central block is not visible once the FCD is fixed with the loop, it is important to make sure that the central

block is in its initial position. Periodically, it is necessary to remove the FCD and check if springs and the blocks are intact as maintenance.

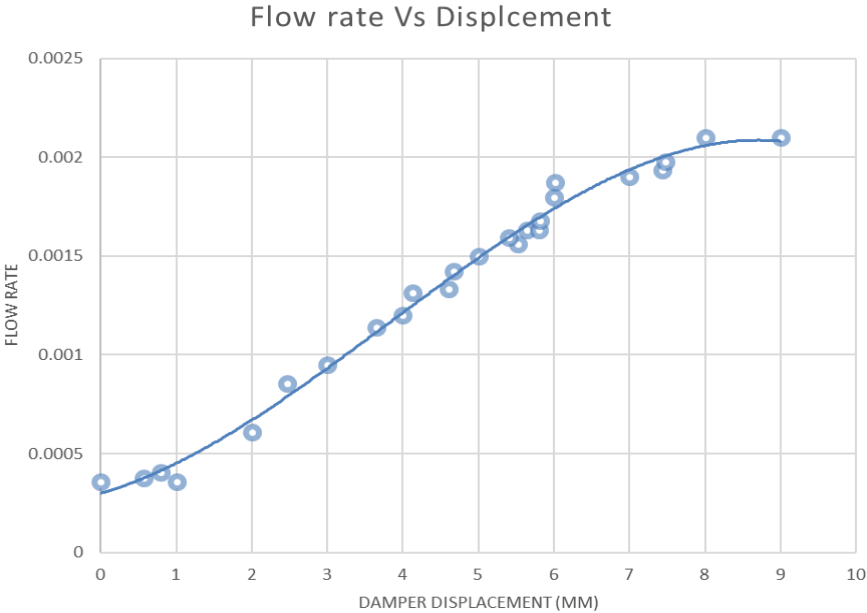

Figure 7 FCD Behavior

As the coolant loop starts running, the coolant temperature inside the flow control device will vary the Nitinol spring stiffness and accordingly regulate the flow passing through the device. The overall movement was designed as needed for cooling according to the regulations placed by ASHRAE W2 envelope.

Chapter 4: EXPERIMENTAL SETUP

The experimental setup used in this study was modeled after the setup that was used in the CFD analysis on 6Sigma. When observed closely, it can be seen that the setup is exactly the same and includes all the sensors as well. The experimental setup was built keeping control strategies in mind. Pressure Sensors and Thermocouples were used specifically in order to test pressure-based and temperature-based control strategies. The Flow Sensors would give us instantaneous flow rate readings on a server level. The pump used in the experiment is capable of PWM control which was necessary while executing particular strategies. To mimic the heat flux of servers, ceramic heaters were used. All of the sensors are integrated into LabVIEW to display all the output generated. These sensors were made sure to be the most ideal model in terms of cost, reliability and quality for this experiment. For the coolant, a solution of 20% Ethylene-Glycol is used since the mixture is non-corrosive. For the main coolant loop, pipes with internal diameter of 0.5" is used. The pipes that run on a server level have an internal diameter of 3/8". To ensure there are no leakages, clamps are used to seal off the section between the pipes and the sensors. Additionally, a by-pass loop with a flow control valve is placed at the top of the setup in case there is high back pressure or there are air gaps in the server pipes.

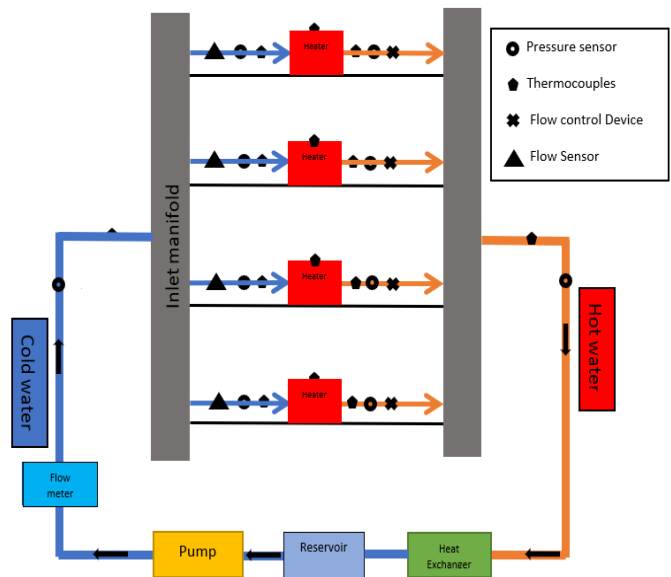

Figure 8 Experimental Setup Schematic

4.1 PRESSURE-BASED CONTROL STRATEGY

This strategy is based on the pressure drop across the system. Using two pressure sensors, the pressure at the inlet and outlet manifolds are measured and the difference can be calculated to find the pressure drop. Additionally, pressure sensors are placed across the cold plates to calculate the pressure

drop across them. Suppose the coolant is running in the rack at a temperature of 25°C, and at this temperature, the pressure drop across the system is P_1 . As the temperature of the water increases, the central block will move and accordingly the flow rate will vary causing a change in the pressure drop which results to P_2 . This change in pressure drop can be studied and accordingly PWM signals can be sent to the pump which would vary the flow rate in the servers in such a way that the overall pressure drop reverts to P_1 . An increase in the pressure drop is an indication that the server is receiving more coolant than it actually needs and hence the FCD is blocking majority of the oncoming flow. A decrease in the pressure drop would mean that the coolant is not being obstructed by the FCD due to the temperature of the coolant increasing from 25°C. These changes can be monitored and accordingly signals can be sent to the pump power source to change the power input. The whole process can be automated if a code is written on a system-design platform like LabVIEW.

4.2 TEMPERATURE-BASED CONTROL STRATEGY

As opposed to controlling the pump in pressure-based control strategy, in temperature-based control strategy we let the FCD vary the flow rate of individual servers. Due to the temperature-dependent nature of the Nitinol spring inside the FCD, the outlet temperature of the server cold plate can move the block to either increase or decrease the flow rate. Even though the power input to the pump would be constant from the power source, the FCD would reduce the flow rate dynamically and due to that the amount of current drawn by the pump should reduce causing significant pumping power savings. In this scenario, the inlet temperature would be maintained constant at an ideal value which can be obtained based on the computational power of individual racks. The difference in heat flux of the servers would determine the inlet temperatures of coolant in an entire rack. The maximum heat flux would determine how much a server would heat up the coolant inside the cold plate, and if an ideal inlet coolant temperature is not chosen for the loop, the FCD might fail to function. This value can be calculated by running simulations of a rack on 6Sigma ET.

Chapter 5: COMPONENTS

Since multiple parameters need to be observed and monitored, sensors had to be strategically placed around the setup. The components were placed in such a manner that it would be ideal while practicing either the pressure-based control strategy or the temperature-based control strategy. The components used in this experiment were bought keeping its future objectives in mind. Multiple experiments can be run using the same setup with very minor changes according to what the experiment might need. The components are not fixed into position permanently at any place with that in mind.

The challenge on having multiple sensors lie in the wiring schematics. Each component is going to have multiple wires and each sensor will have a different wiring schematic. The heaters needed switches to control the power input and these switches could only be controlled using an Arduino which calls for more wires. Having a sensible way to arrange them and color code them would go a long way in identifying and organizing the experimental setup. The table below shows the color code that was followed in this experimental setup.

Color of the Wire	Corresponding Output
Red	Live Supply Current
Black	Grounding/ Earthing
White	Pressure Sensor
Green	Flow Sensor
Blue	PWM from Arduino
Silver	Thermocouple

The subsections in this chapter is to describe the specification, function, and wiring schematic of the various sensors and equipment that were used to build the setup. Every sensor is wired in such a way that their output is seen on LabVIEW, making it easier if the system needs to be automated. The data can be read in real-time and used to achieve control over the cooling loop.

5.1 CERAMIC HEATERS

Ceramic Heaters are basically resistive heating elements that are used to imitate the heat flux given out by servers. The amount of heat flux can be dynamically be varied using PWM control through an Arduino. Copper blocks are fixed on top of these ceramic heaters using high conductivity thermal adhesive for two reasons, first being their poor heat transfer abilities and the second reason is to have an opening to insert a thermocouple. If the ceramic heater were in direct contact with the cold plate without the help of thermal grease, the heater would not stay in one place and using thermal adhesive would create a permanent bond making it difficult to replace either the heater or the cold plate in case either of them malfunction. Also, the dynamic nature of copper will prove to be ideal when instantaneous temperatures need to be noted and observed. To have an idea of the temperatures, a T-Type Thermocouple is placed inside the copper block. This gave an idea as to how different power settings effected the temperature of the ceramic heater. The resistance of every ceramic heater is constant at 10Ω.

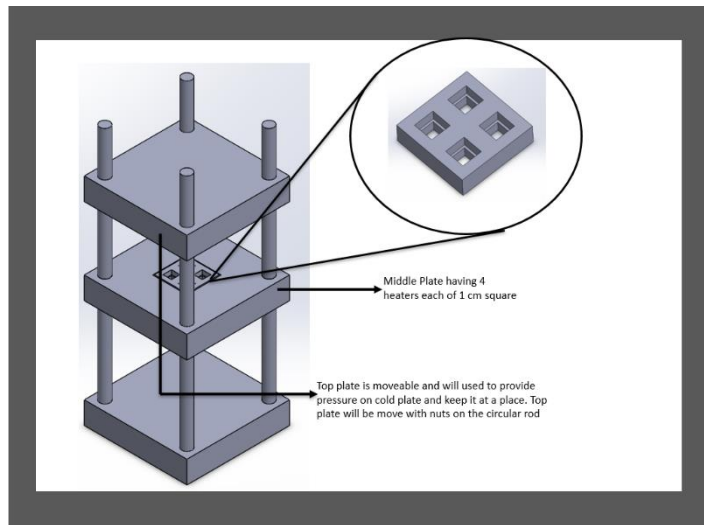

Figure 9 Server Replication Schematic

Varying the supply power to the heaters is a tedious and risky thing to do, switches are used. A separate power source is used specifically for the heaters. The input supply voltage is set to a certain

amount and initially the current drawn should be zero. When the PWM signals are sent to the switch, according to the supply voltage, a calculated amount of current will be drawn by the ceramic heaters causing an increase in temperature. A PWM control program is designed specifically for the heaters.

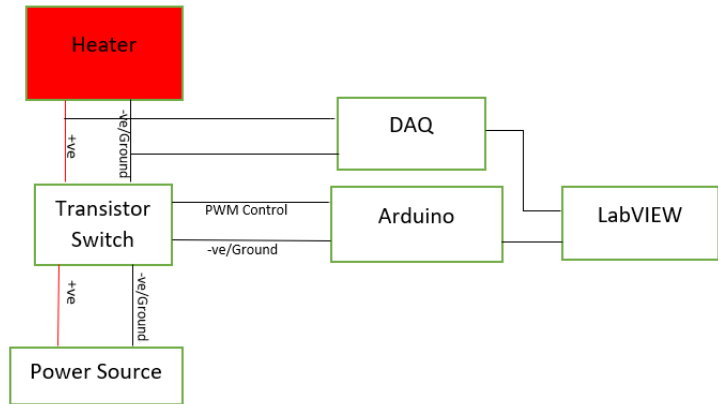

Figure 10 Ceramic Heater Wiring Schematic

Supplying a high amount of power to one heater may be potentially hazardous and it might cause the heater to short out. To imitate a server, four of these ceramic heaters are clubbed together in a pattern shown below. Each of the heaters can be controlled separately in order to create hotspots. The experiment will show how effective the strategies are in eliminating these hotspots. A total of 16 ceramic heaters were used in this 4-server setup.

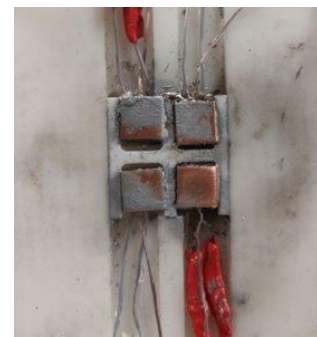

Figure 11 Heater Cluster

5.2 PRESSURE TRANSDUCERS

Honeywell PX2 series heavy duty pressure transducers are used to measure pressure across the setup. These transducers use piezoresistive technology which senses minute changes in pressure and gives accurate readings. It is important to get instantaneous changes as the strategies that are tested majorly depend on the pressure readings. There are pressure sensors placed on either side of the cold plate to find out how much it effected the flow rate. Pressure sensors are placed at the inlet and the outlet of the entire setup to monitor the pressure drop. This pressure drop is the factor that would decide the PWM setting of the pump in the pressure-based control strategy.



Figure 12 Pressure Transducer

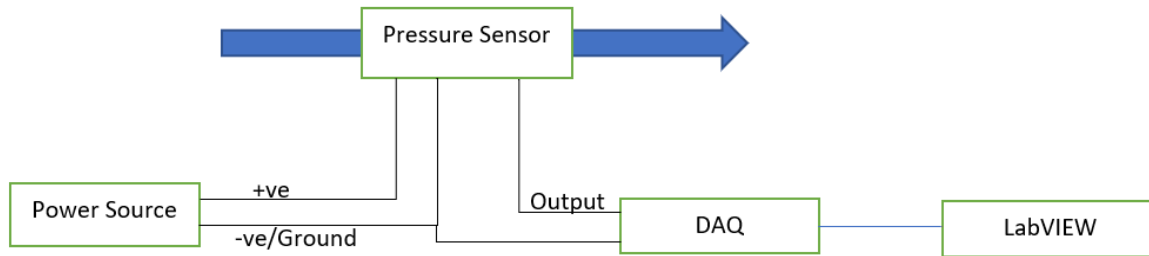

Figure 13 Pressure Sensor Wiring Schematic

The pressure sensor has three wires of supply current, ground and the output. The output signal is in DC Voltage. This output can be converted to pressure readings in any of the preferred units. The scale for converting the output is provided in the data sheet online. The pressure sensors operate at a supply voltage of 5V. A separate power source was used to deliver the required supply voltage to these sensors.

5.3 THERMOCOUPLES

Thermocouples are used to measure temperatures across various points of the setup. Primarily, heater temperatures and coolant temperatures are measured using these thermocouples. Two different types of thermocouples are used in the system.

The first one is a K-Type Thermocouple which is capable of measuring a lower range of temperatures and hence were used to measure the coolant temperature across servers and the entire loop. The K-Type Thermocouple at the outlet is placed near the FCD to observe the outlet temperature. This can help us determine what percentage of the FCD is open from the hysteresis obtained previously. Additionally, it is



Figure 14 K-Type Thermocouple

used to make sure that the inlet temperatures are constant and is maintained at the required temperature.

The second one is a T-Type Thermocouple which can measure relatively higher temperatures. These thermocouples can be obtained in various sizes and since the hole in the copper block is relatively small, T-Type Thermocouples are an ideal choice to measure their temperatures. T-Type Thermocouples are just two wires made of copper and nickel spot welded at the end which needs to measure the temperature. The hole on the copper block was made after considering the dimensions of the T-Type Thermocouples.



Figure 15 T-Type Thermocouple

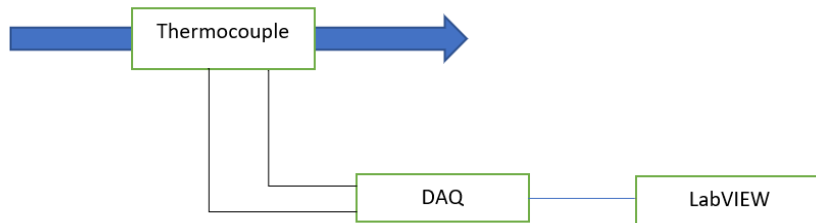

Figure 16 Thermocouple Wiring Schematic

Both types of thermocouples can be wired straight to the Data Acquisition Unit where the type of thermocouple can be mentioned and the reading of temperatures can be obtained without too much hassle. A code was written on LabVIEW to measure and record these temperature readings at any desired interval.

5.4 FLOW RATE SENSORS

Omega flow sensors are used in this experimental setup to measure flow rates at the inlet of each servers. These sensors have a miniature turbine on the inside which rotates when coolant flows through it. The rotation of the turbine generates an output in terms of frequency which can then be scaled using the data sheet graph to find out what the exact flow rate of the coolant is instantaneously. The minimum flow rate that the sensor can measure is 0.1 LPM which gives a good enough margin for the experiments that will be conducted using this setup. If there are any contaminants in the coolant, there is a possibility of the contaminant causing hindrance in the turbine blades causing the flow sensor to give inaccurate readings. Occasionally cleaning the sensor out is recommended to avoid this problem.



Figure 17 Omega Flow Sensor

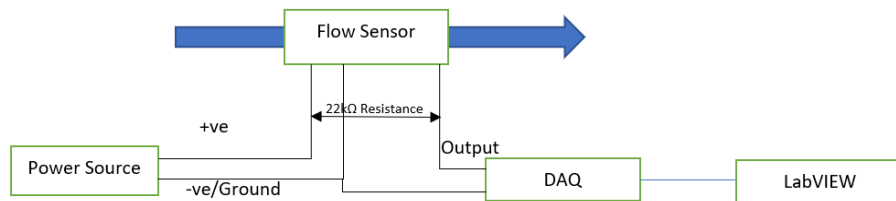

Figure 18 Flow Sensor Wiring Schematic

The flow sensor has 3 wires similar to the pressure sensor. It has a supply wire, ground and output. The output here is in hertz which can then be scaled as mentioned above. The wiring schematic included a resistance across the output and live wire to scale the output down according to the data sheet provided by the manufacturer.

5.5 PUMP

An EK-XTOP Revo D5 PWM Pump is used to pump the coolant into the rack in the experimental setup. The pump has an operating voltage range of 8-24V of DC Current. The pump is attached at the bottom of the loop just before the coolant is supposed to enter the servers. An additional filter was attached before the coolant enters the pump to reduce the number of contaminants. The maximum flow rate observed with the pump was about 1.2 LPM. Due to the pump being attached at the bottom, the distribution of coolant in the servers becomes quite uneven.



Figure 19 Pump

The pump plays a major role in the experiment as this component is one of the primary ways to vary the flow rate. Due to this reason, a separate power supply was used. A separate power supply provided a way to vary the input current given to the pump. Another way to achieve this is through PWM control which is inbuilt in this variant of the pump. A snippet of code was written on LabVIEW to control the pump output. During PWM control, the power source is set at a constant voltage with room for current to be varied. It is recommended to set the voltage to a higher value as current can be finely varied using PWM. In order to avoid any interference, a separate Arduino was assigned specifically to the pump.



Figure 20 Inbuilt PWM Port

5.6 DATA ACQUISITION UNIT

A major component which is responsible for assembling all the data that the sensors have to offer. The Data Acquisition Unit (DAQ) can receive signals from the sensors sequentially and process them.

The DAQ has its own application which is capable of processing all this data and displaying it in one window. Despite that, LabVIEW is preferred due to the ability to automate the system.

The DAQ used for this experiment is Agilent 34970A Data Logger with ports to insert 3 multiplexers. Agilent 34901A 20-Channel Armature Multiplexers are preferred. A total of 40 channels were used across 3 multiplexers to obtain different kinds of sensor data. Four of them were used to log Flow Rates, ten to log Pressure Readings, ten more to log K-Type Thermocouple Coolant Temperatures, and sixteen to log T-Type Thermocouple Heater Temperatures across four servers. The DAQ is connected to desktop using a USB although there are provisions to connect the DAQ using a couple of other methods. LabVIEW works in sync with the DAQ to obtain and process all the output signals from the DAQ.

Chapter 6: LabVIEW INTEGRATION

For all the sensors to be working in conjunction with each other, a mediating software was necessary. LabVIEW is a system-design platform which is used to grab all the sensor data and display all the values in one window. The code is designed to take readings at specified intervals and display them on the front panel. At the end of the experiment, when the program is terminated, a prompt appears in order to save the files as comma separated values (CSV). The program was designed in a way that data from different types of sensors are stored in different files rather than the same.

Two different programs were written individually for PWM Control and to collect and store sensor data. The main intention behind writing two separate programs was to avoid confusion between two functions and to remove the dependency between PWM and Sensors. In the initial testing phase, if the correct Arduino port number wasn't entered, the program would fail to execute and crash creating a need to restart the program. Once the final setup is complete, the two programs can be integrated into one and can be used without any hindrance.

6.1 SENSOR INTEGRATION

Since the data is not directly being collected by the computer, LabVIEW would not be able to process it directly. A separate set of drivers need to be installed in order to be able to communicate with the DAQ. These drivers are available to download for free online. Once these drivers are installed, a set of DAQ related functions will appear which can be used to process data. There are separate blocks for Voltage, Frequency and Temperatures which need to be initialized and set up in order for them to function in congruence.

The screen snip below shows the back end of the code that was designed. From left to right, we go through initialization, obtaining sensor data, scaling the output, saving the file and to resetting the whole program. The first step is the initialization of the DAQ which essentially sends a signal to the DAQ to start processing all the input sent by the LabVIEW program. The second step is the actual program that is responsible for controlling the DAQ. Each module senses different types of output from the DAQ. The

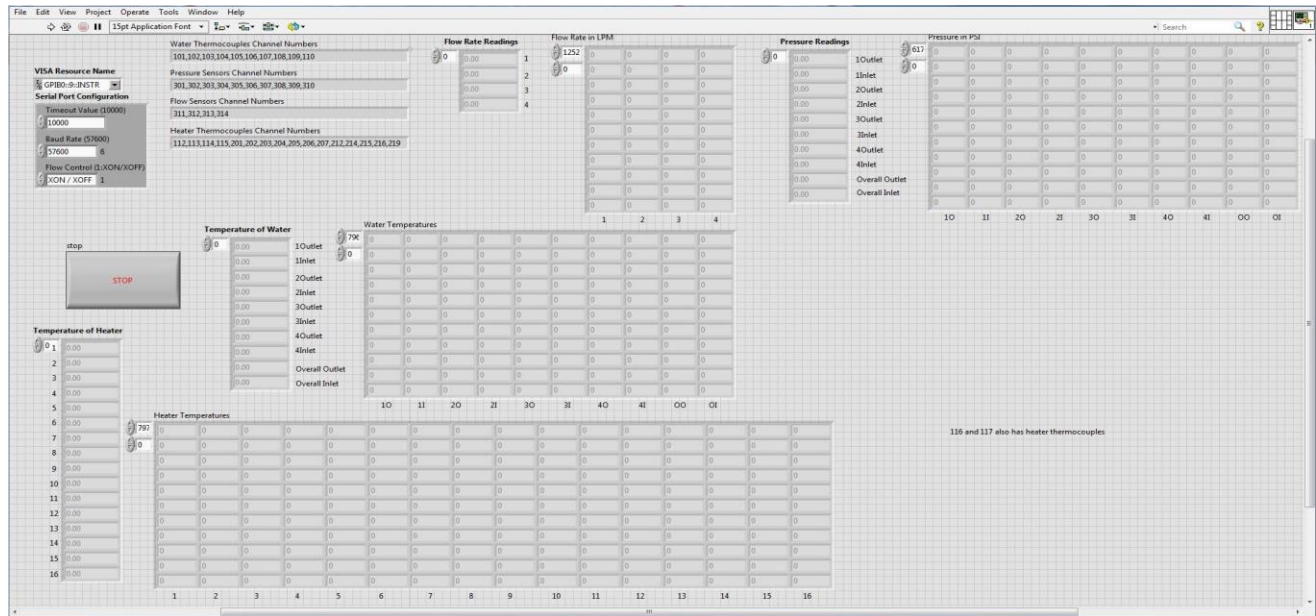

Figure 22 Sensor Data Collection Front Panel

The image shown here is the front panel where all the readings are displayed. On the top right is the indicator to select the USB port where the DAQ is connected. This resets every time LabVIEW is closed. Right beside this is the section that displays the channel number on the DAQ where the output from different kinds of sensors are wired. In order to change these numbers, the back end of the program will have to be accessed. The arrays everywhere display the sensor data. In this section, the portion on the left that is vertically placed displays the most recent value and the array on the right can be accessed if any of the past data needs to be accessed. In the top-middle portion, the flow sensor data is displayed, to its right Pressure Readings are shown from the pressure sensors, in the middle coolant temperature readings are displayed, and at the bottom heater thermocouple temperatures are shown. The stop button seen on the image terminates the while loop activating the prompt to save all the data.

6.2 ARDUINO INTEGRATION

Previously, a separate application was required in order to communicate with an Arduino. LabVIEW released a new driver called LINX that enables Arduino programming using LabVIEW. The LINX driver is available to download from the Arduino website and once this is installed, programs can be uploaded to the Arduino using LabVIEW.

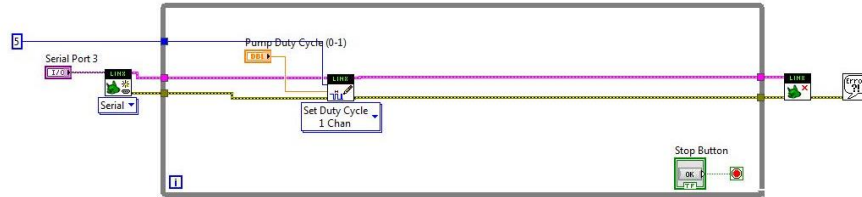

Figure 23 Pump PWM Integration Code

In the experimental setup, two main components need to be controlled using PWM, the heaters and the pump. A combined program was written in order to achieve this. The image below shows the actual code of the program. On installing the LINX driver, we get access to a library of all Arduino related operations. The program here is relatively more simplistic when compared to reading sensor data directly. A block

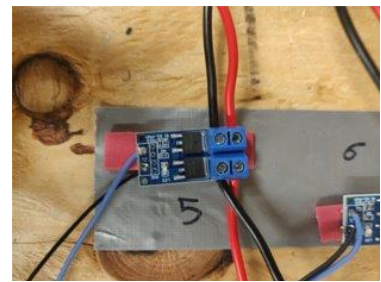

Figure 25 Switch to Control Heater

called Set Duty Cycle for N Channels is used. This block is capable of varying the PWM output channels in an Arduino on entering the channel numbers and the desired duty cycle. The duty cycle essentially signifies the percentage of maximum current that should be allowed to pass through. The PWM ports of the Arduino are connected to switches of the heater which regulate the flow of current. The duty cycle can be varied between zero and one. This allows for fine control of the power supplied to the heaters.

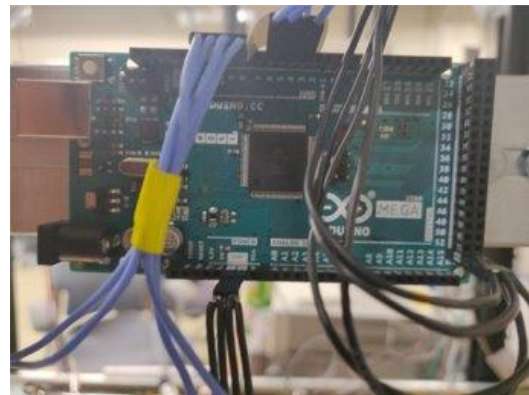

Figure 24 Arduino for Heaters

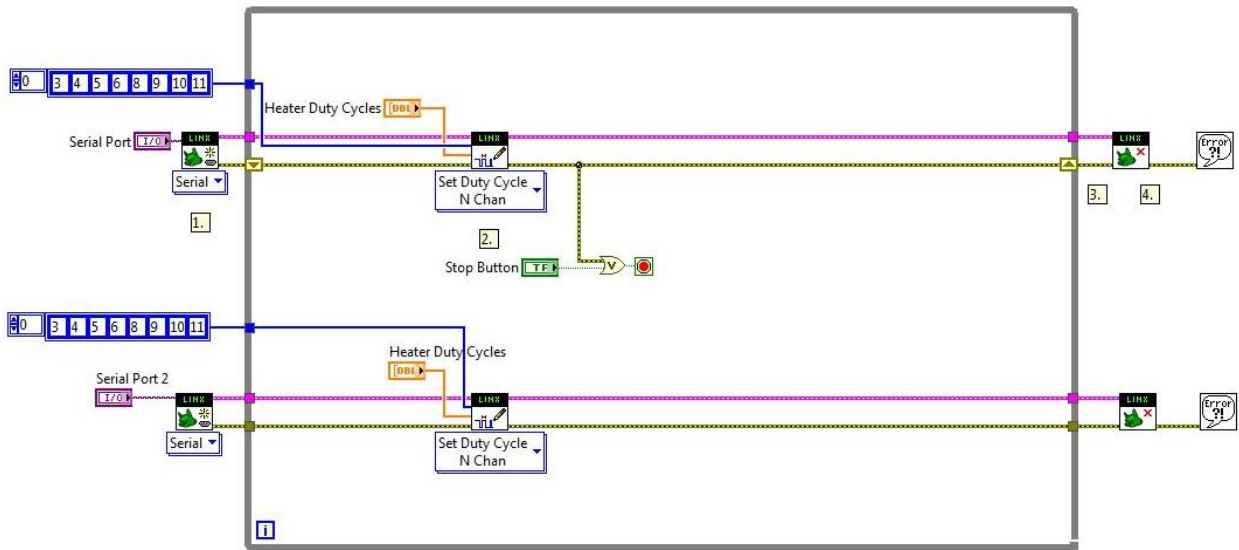

Figure 26 Heater PWM Code

Each of the heater will take up one PWM port of an Arduino and since there are 16 heaters, 16 PWM ports are needed. Two types of microcontrollers are used to build this setup, Arduino Mega 2560 and Arduino Uno. Since an Arduino Mega 2560 has only 12 PWM ports, two of these microcontrollers were used to control the heater switches alone. The Pump also needed PWM controller and hence an Arduino Uno was used to achieve this. The COM ports need to be selected for individual Arduinos every time LabVIEW is opened. The PWM ports have been preset in the program but can be changed if necessary.

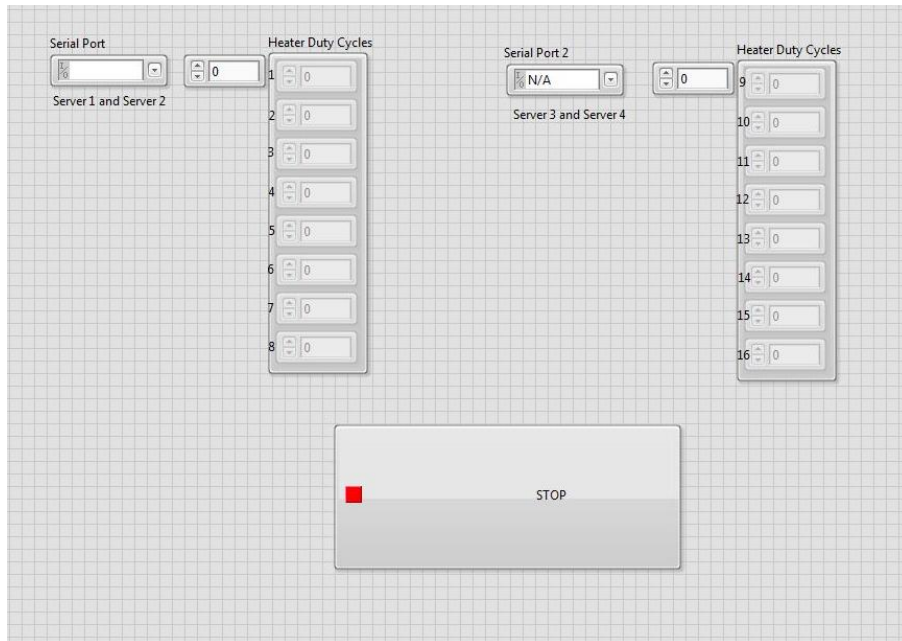

Figure 27 Heater Duty Cycle Variation Panel

The image over here shows the front panel of the program where the duty cycle can be changed once the program is up and running. Changing the duty cycle will vary the output of the PWM port and accordingly trigger the switch corresponding to the port changing the power supplied. The only difference here between the heater and the pump is that the pump has an inbuilt switch.

Chapter 7: RESULTS

A couple of experiments were conducted to test the functionality of the Flow Control Device and its effect on dynamic cooling. The pump input power was kept at a constant voltage of 12V and had variable current for the Arduino to control. During this experimental run, the flow rate was observed while the temperature of the coolant was varied between 10°C and 50°C using the heat exchanger.

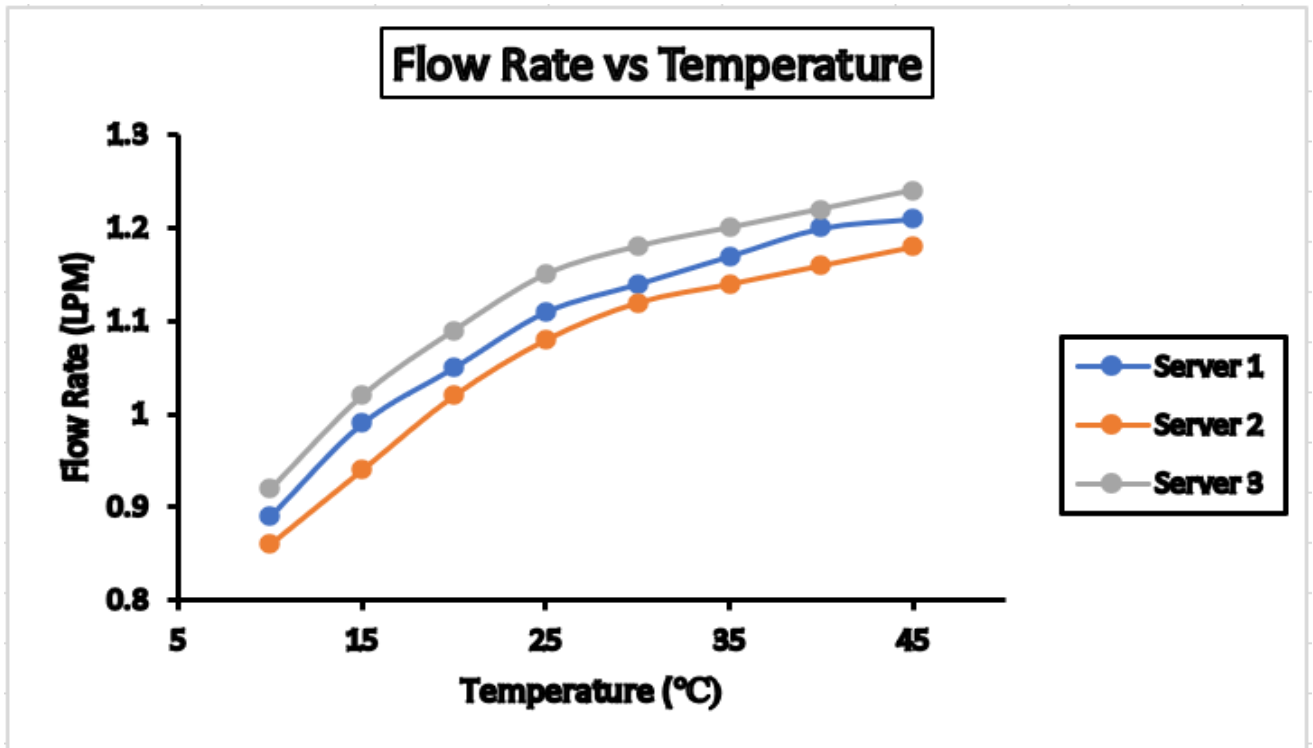

Figure 28 Experimental Results

The graph shows the variation of flow rate with temperature. From the results, it is observed that the flow rate varies between 0.86 to 1.15. This is around 37% variation of flow rate due to the FCD responding to the increase in temperature and allowing more flow to pass through the FCD. This proves that the concept of dynamic cooling can be applied to racks with a functional FCD is placed.

Chapter 8: CONCLUSION

With the experimental runs conducted using this setup, the efficiency in terms of pumping power savings using dynamic cooling is evident. The variation of flow rate with temperature shows that the pump can be placed at a lower supply power using PWM control and then when the temperature of a server outlet increases, the duty cycle of the pump PWM port can be changed to make sure that the outlet temperature reverts to the original value. This would be the approach towards temperature-based control strategy. Similarly, for pressure-based control strategy, the change in the overall pressure drop can be taken as a parameter to control the duty cycle of the pump and maintain an equilibrium in the rack. This experimental setup is equipped with sensors that is commonly used in many experiments. This was done so that the setup can serve as a base for future experiments. The issue of contamination related failures limit cost effective air-cooling techniques to be successfully implemented for data centers looking to lower their PUE. While it's true that air cooling will continue to dominate the data center cooling industry, especially for enterprise storage systems, and latest phase change and direct immersion cooling techniques are also being used for cooling high performance clusters, indirect liquid cooling presents the simplest and the best option for cooling high heat fluxes without significant changes to existing data center infrastructure [11-20].

This setup can be used in characterization of various cold plates as it is easy to replace the cold plates that are currently attached in the rack. It can be used to study the response delay time of Flow Control Devices where the time lag is studied to see the effectiveness of the FCD. Experiments can be run solely on a temperature dependent strategy without a Flow Control Device. Electronically controlled FCDs are being developed that can follow the same testing procedure using this experimental setup. Overall, with the experiments that were run in the current study, significant variation in flow rates gives an insight on how the pump can be controlled using PWM to save pumping power. Just through temperature variations, the FCD was able to bring 37% of variation in flow rate. Further testing will be needed to improve the efficiency of dynamic cooling using Flow Control Devices.

REFERENCES

- [1] Fernandes, J. E. (2015). Minimizing Power Consumption At Module, Server And Rack-levels Within A Data Center Through Design And Energy-efficient Operation Of Dynamic Cooling Solutions.
- [2] J. E. Fernandes, M. Sahini, D. Agonafer, V. Mulay, J. Na, P. McGinn, M. Soares and C. Turner, "Evaluating Liquid Cooling at the Rack: Comparing Distributed and Centralized Pumping," in *International Microelectronics Assembly and Packaging Society (IMAPS Thermal)*, Los Gatos, 2014.
- [3] H. Coles and S. Greenberg, "Direct Liquid cooling for electronic equipment," Earnest Orlando Lawrence Berkely National Laboratory, 2014.
- [4] C. Jennings, "Data Center Energy Consumption," 29 Dec 2015. [Online]. Available: <http://www.hainc.com/blog/entry/data-center-energy-consumption/>.
- [5] A. Almoli, A. Thompson, N. Kapur, 1. Summers, H. Thompson, and G. Hannah, "Computational Fluid Dynamic Investigation of Liquid Cooling in DataCenters, " *Applied Energy*, vol. 89, pp. 150-155, 2012.
- [6] M. 1. Ellsworth Jr. and M. K. Iyengar, "Energy Efficiency Analyses and Comparison of Air- and Water-Cooled High-Performance Servers, " in *ASME InterPACK Conference*, San Francisco, CA, 2009.
- [7] S. Zimmermann, I. Meijer, M. K. Tiwari, S. Parades and B. Michel, "Aquasar: A Hot Water-Cooled Data Center with Direct Energy Reuse, " *Energy*, vol. 43, pp. 237- 245, 2012.
- [8] R. C. Chu, U. P. Hwang, and R. E. Simons, "Conduction Cooling for an LSI Package: A One-Dimensional Approach, " *IBM Journal of Research and Development*, vol. 26, no. 1, pp. 45-54, 1982.
- [9] ASHRAE TC 9.9, "2011 Thermal Guidelines for Liquid Cooled Data Processing Environments, " ASHRAE, Atlanta, GA, 2011.
- [10] Sahini, Manasa. "Experimental and Computational Study of Multi-level Cooling Systems at Elevated Coolant Temperatures in Data Centers." PhD diss., 2017.
- [11] Jimil M. Shah, Chinmay Bhatt, Pranavi Rachamreddy, Ravya Dandamudi, Satyam Saini, Dereje Agonafer, 2019, Computational Form Factor Study of a 3rd Generation Open Compute Server for Single-Phase Immersion Cooling, ASME Conference Paper No. IPACK2019-6602
- [12] Dhruvkumar Gandhi, Uschas Chowdhury, Tushar Chauhan, Pratik Bansode, Satyam Saini, Jimil M. Shah and Dereje Agonafer, 2019, Computational analysis for thermal optimization of server for single phase immersion cooling, ASME Conference Paper No. IPACK2019-6587

- [13] Pravin A Shinde, Pratik V Bansode, Satyam Saini, Rajesh Kasukurthy, Tushar Chauhan, Jimil M Shah and Dereje Agonafer, 2019, Experimental analysis for optimization of thermal performance of a server in single phase immersion cooling, ASME Conference Paper No. IPACK2019-6590
- [14] Jimil M. Shah, Roshan Anand, Satyam Saini, Rawhan Cyriac, Dereje Agonafer, Prabjit Singh, Mike Kaler, 2019, Development of A Technique to Measure Deliquescent Relative Humidity of Particulate Contaminants and Determination of the Operating Relative Humidity of a Data Center, ASME Conference Paper No. IPACK2019-6601
- [15]Gautham Thirunavakkarasu, Satyam Saini, Jimil Shah, Dereje Agonafer,2018, Airflow pattern and path flow simulation of airborne particulate contaminants in a high-density Data Center utilizing Airside Economization, ASME Conference Paper No. IPACK2018-8436
- [16] Kumar, A., Shahi, P., & Saha, S. K. Experimental Study of Latent Heat Thermal Energy Storage System for Medium Temperature Solar Applications.
- [17] Saini, Satyam. Airflow Path and Flow Pattern Analysis of Sub-Micron Particulate Contaminants in a Data Center with Hot Aisle Containment System Utilizing Direct Air Cooling. Diss. 2018.
- [18] Dehkordi, B. G., Fallah, S., & Niazmand, A. (2014). Investigation of harmonic instability of laminar fluid flow past 2D rectangular cross sections with 0.5–4 aspect ratios. Proceedings of the Institution of Mechanical Engineers, Part C: Journal of Mechanical Engineering Science, 228(5), 828–839. <https://doi.org/10.1177/0954406213491906>
- [19] Shahi, Pardeep, 2016, "Experimental Analysis of PCM based Thermal Storage System for Solar Power Plant," M.S. thesis, Indian Institute of Technology- Mumbai.
- [20] Pardeep Shahi, Sartha Agarwal, Satyam Saini, Pratik Bansode, Amireza Niazmand, Dereje Agonafer, 2020, "CFD Analysis on Liquid Cooled Cold Plate Using Copper Nanoparticles", ASME Conference Paper No. IPACK2020-2592
- [21] R. Kasukurthy, P. S. Challa, R. R. Palanikumar, B. R. Manimaran and D. Agonafer, "Flow Analysis and Linearization of Rectangular Butterfly Valve Flow Control Device for Liquid Cooling," 2018 17th IEEE Intersociety Conference on Thermal and Thermomechanical Phenomena in Electronic Systems (ITherm), San Diego, CA, 2018, pp. 683-687, doi: 10.1109/ITHERM.2018.8419503.
- [22] M. K. Patterson, "Liquid cooling Guidelines," 14 November 2011. [Online]. Available: <http://delivery.acm.org/10.1145/2160000>.

BIOGRAPHICAL INFORMATION

Akash FNU was born in Dombivili, Maharashtra, India and was brought up in Manipal, Karnataka. He did all his schooling in Manipal until he obtained his Undergraduate degree in Aeronautical Engineering in May 2017. He moved to the United States in August 2018 to attend school for Master's of Science degree in Aerospace Engineering at the University of Texas at Arlington. He started working in Dr. Agonafer's research group in August 2019 and his thesis focused on Dynamic Cooling of Racks using Flow Control Devices.