

THE STUDY OF THE EFFECT OF SMART METER
RF TRANSMISSIONS ON GROUND FAULT
CIRCUIT INTERRUPTERS

by

SIMON DONAHUE

Presented to the Faculty of the Graduate School of
The University of Texas at Arlington in Partial Fulfillment
of the Requirements
for the Degree of

MASTER OF SCIENCE IN ELECTRICAL ENGINEERING

THE UNIVERSITY OF TEXAS AT ARLINGTON

DECEMBER 2014

Copyright © by Simon Donahue 2014

All Rights Reserved



Acknowledgements

I would like to thank Dr. Wetz for not only recruiting me, but for being understanding when deciding whether to stay in school or move on to the real world, as well as being patient with me (most of the time), and being a great teacher. I'd like to thank Dr. Wei-Jen Lee and Dr. Gregory Turner for their time and support as members of my committee. I'd like to express sincere thanks to CoServ for their financial support of this effort. I'd also like to thank all my colleagues, particularly Clint, Isaac and Matt, for convincing me to stay and finishing what I had started. And of course, I'd like to thank my family for supporting me on my somewhat unplanned journey through school, believing in me unconditionally, and giving me way more help than I deserve.

September 29, 2014

Abstract

THE STUDY OF THE EFFECT OF SMART METER
RF TRANSMISSIONS ON GROUND FAULT
CIRCUIT INTERRUPTERS

Simon Donahue, M.S.

The University of Texas at Arlington, 2014

Supervising Professor: David Alan Wetz Jr.

Research and development is currently being performed to transform the United States' utility electric grid into a 'Smart Grid' [1,2] with the purpose of more efficiently distributing power, giving more control over the grid itself, and creating the potential savings for consumers. Smart Meters are among the first intelligent metering devices used within the 'Smart Grid' concept, allowing consumers to effectively track their power usage within their home. They have thus far been deployed in thousands of commercial and residential electrical installations around the US [3,4]. While the wide scale deployment of these devices has initially proven very successful, there is still much that is unknown about how they will impact the long-term operation of a large utility grid or the electrical devices sourced by them [5]. One such device, whose operation appears to be impacted by the Smart Meter, under specific conditions, is a ground fault circuit interrupter (GFCI). It has been reported that the RF transmissions from Smart Meters can induce false tripping events on GFCI outlets installed on temporary construction poles. In an effort to understand why this may happen, a research study, which is presented here, has been performed to understand the correlation between RF transmissions and GFCI tripping events on construction poles.

Table of Contents

Acknowledgements	iii
Abstract	iv
List of Illustrations	vii
List of Tables	xi
Chapter 1 Introduction.....	1
1.1 The Problem and the History.....	1
1.1.1 Introduction and The Problem	1
1.1.2 Brief History of GFCIs	4
Chapter 2 Background	7
2.1 Basic GFCI Operation	7
2.1.1 Normal Operation	7
2.1.2 Test Button State and Example.....	8
2.1.4 Ground Neutral Fault Occurrence	10
2.2 Basic Smart Meter Operation	13
2.3 Possible Causes of Tripping.....	15
2.4 Previous Work	17
Chapter 3 Experimental Design and Procedure	21
3.1 Experiments.....	21
3.1.1 Transmission Field Mapping	21
3.1.2 Differential Transformer Measurements with Load (Distance Testing).....	24
3.1.3 Operation using Circuit Isolation	27
3.1.4 Differential Transformer Measurements without Load	28
Chapter 4 Experimental Results	30

4.1 Distance Testing Results (with Load)	30
4.2 Results – Non-UPS Experiments	35
4.3 Results – UPS Experiments	38
Chapter 5 Additional Testing and Notes	41
5.1 Brass vs. Copper	41
5.2 Antenna Testing.....	42
Chapter 6 Conclusion.....	45
6.1 Proposed Solution	45
6.2 Discussion	48
6.3 Future Work.....	55
9.3 Conclusion	56
References.....	59
Biographical Information	62

List of Illustrations

Figure 1-1 Laboratory setup representing a construction pole with GFCI electrical panel and vertically adjustable Smart Meter inside an anechoic chamber. 2

Figure 1-3 Effects of different amounts of current as a result of electrical shock on the human body. UL 943 lies between the perception level, in which a human can feel the electric shock, and the let-go threshold, which is right before muscles will “freeze” during electrocution not allowing a person to let go of whatever they’re gripping. 5

Figure 1-4 Number of deaths per year in the United States compared with the number of GFCI’s installed in homes. 6

Figure 2-1 Basic GFCI operation with no fault current detected and equal current flowing through the forward path, into the connected load, and then back through the return path. Since the same current is flowing in and out of the transformer there are no trips occurring. The black line is the “hot” (forward), and the white is the “neutral” (return). 8

Figure 2-2 Test button operation of a GFCI unit. In this scenario, the test button of a GFCI has been pressed. This introduces a “test resistor” to the circuit between the hot and neutral lines. Since the current is no longer equally flowing in and out of the transformer, the transformer will send an input to the sense electronics which will then disconnect the hot line. 9

Figure 2-3 A scenario in which a GFCI has experienced a tripping event. A foreign load has been introduced between the hot line and earth ground. Instead of current flowing through the neutral line return path, the current now flows to ground. When this occurs, the amount of current flowing in and out of the transformer is not equal, causing it to send an input to the sense electronics, which then disconnect the load. 10

Figure 2-4 A scenario in which a GFCI has experienced a tripping event. A foreign load has been introduced between the hot line and earth ground. Instead of current flowing

through the neutral line return path, the current now flows to ground. When this occurs, the amount of current flowing in and out of the transformer is not equal, causing it to send an input to the sense electronics, which then disconnect the load. 13

Figure 2-5 A Landis+Gyr FOCUS AXR-SD 120V Smart Meter, used in all tests throughout this study. 15

Figure 3-1 Angles marked on the Smart Meter for reference as to where measurements were taken in relation to position on the rotary table. 22

Figure 3-2 B-field measured axially for varying distances between 0 and 90 degrees. ... 23

Figure 3-3 E-field measured axially for varying distances between 0 and 90 degrees. ... 23

Figure 3-4 B-field measured axially in terms of dBm for varying distances between 0 and 90 degrees. This representation more clearly depicts the field's "hotspot" being emitted by the Smart Meter at roughly the 45-degree mark. 25

Figure 3-5 Experimental setup consisting of a 120V Smart Meter, B-field and E-field probes, UPS, two spectrum analyzers, and GFCI outlet box. 27

Figure 4-1 Tripping event measured across the differential transformer. Top: B-field measured from RF transmissions of the Smart Meter, Bottom: differential transformer voltage measured across the same time span as the RF transmissions. Each color of the RF transmissions corresponds with the differential voltage waveform colors. 36

Figure 4-2 Tripping event of ground-neutral transformer. Top: b-field created from RF transmissions of Smart Meter, Bottom: ground-neutral transformer voltage during the same time span as the RF transmissions. Each color of the RF transmissions corresponds with the ground-neutral voltage waveforms of the same color. 37

Figure 4-3 Tripping event of differential transformer while GFCI is powered from UPS. Top: B-field created from RF transmissions of Smart Meter, Bottom: differential transformer voltage during the same time span as the RF transmissions. Each color of

the RF transmissions corresponds with the differential voltage waveforms of the same color..... 39

Figure 4-4 Tripping event of ground-neutral transformer while GFCI is powered from UPS. Top: B-field created from RF transmissions of Smart Meter, Bottom: ground-neutral transformer voltage during the same time span as the RF transmissions. Each color of the RF transmissions corresponds with the ground-neutral voltage waveforms of the same color..... 40

Figure 5-1 A GFCI with copper tape wrapped around the hot and neutral brass conductors. This successfully prevented any tripping from occurring. 42

Figure 5-2 A screen capture from a video recording of evidence of GFCI tripping due to RF interference of a Smart Meter. Here, it can be seen that the wires being used to power the GFCI off of the Smart Meter are put in a circular fashion. It was found that this increased tripping events, and is possibly acting as an antenna..... 43

Figure 6-1 Ferrite beads placed on the hot, neutral, and earth ground lines of two brands of GFCIs. Note, the two ferrites on the hot line, though this proved to be unnecessary. The far right device is a regular outlet and not a GFCI..... 46

Figure 6-2 Ferrite applied from within the Smart Meter, one on the red and white wires, and one on the blue and green wires. These locations were provided by the contracting company and were claimed to be preventing any tripping from occurring. 47

Figure 6-3 Voltage measurements of the differential transformer of a modified GFCI while ferrite beads are applied to its hot, neutral, and earth ground wires, and during RF transmission of the Smart Meter. It's clear that there is much less noise than during the distance testing with the modified GFCI previously (Figures 4-1 through 4-4). The extra spike is an anomaly that couldn't be identified (a new light bulb was used as the other one burnt out), but didn't hinder any performance of the load..... 49

Figure 6-4 The construction stand used for testing the Smart Meter and GFCIs. Note that the fronts of the metal compartments are missing, but during tests were placed back on in attempt to replicate as closely as possible the scenario found on construction sites. 54

Figure 6-5 An example of how power phase, and thus current phase, of inductive loads can trick GFCIs into seeing a differential of current moving through them and causing trips. This could be a potential cause of trips for construction sites if they use certain power tools. 56

List of Tables

Table 4-1 The approximate transmitting peak, normal operating peak, and the differential between the two when comparing GFCI differential transformer measurements at different distances. 35

Table 6-1 Ferrite bead testing in multiple arrangements. Each test was repeated three times and the time before a trip occurred was recorded..... 47

Chapter 1

Introduction

1.1 The Problem and the History

1.1.1 Introduction and The Problem

Recently, electrical contractors in North Texas have experienced repeated and uncontrollable ground fault circuit interrupter (GFCI) tripping events, without the presence of any water or known leakage current. These events are believed to be the result of interference induced in the GFCI from the Smart Meter's RF transmissions. These were observed to occur when the GFCI is located in close proximity, within 0.5 m typically, to the Smart Meter. Controlled investigations in the laboratory have shown that the tripping events are repeatable and it has been found that the RF transmissions from the Smart Meter's wireless radio are likely the cause of the unexpected GFCI tripping events. The tripping is caused through the coupling of the roughly 900 – 930 MHz transmissions into the sense electronics within the GFCI. The coupling is comprised of both conductive and radiated components, though it is unclear which is more dominant. This paper will describe the investigative process that has been performed to understand how the interference is induced and how it can be simply remedied.

A GFCI is a "residual-current device" that is capable of disconnecting the grid from applied loads when it detects a 5 to 6 mA current imbalance in the forward and return paths of the circuit to which it is connected [6]. These rules are set by Underwriters Laboratories, a safety consulting company, in their UL943 documentation for safety requirements regarding GFCI receptacles. [7] UL943 stipulates that the load must be disconnected must within 6 ms, solved via Equation 1:

$$T = \frac{20^{1.43}}{i} \quad (1)$$

where i is expressed in terms of milliamperes and T is expressed in terms of seconds. In this case, if i were to be 6 mA then T would be 5.59, which is just under 6 ms. This is the rule for all Class A GFCIs where fault current must be between 6 mA and 264 mA. For reference, a Class B amplifier's range is between 20 mA and 1056 mA.

These devices have been widely implemented in residential and commercial buildings for decades. Typically, GFCIs are required in any electrical installation where water may interfere with electronics, such as kitchens and bathrooms. One such installation includes the construction poles, which are exposed to the elements, used by workers while constructing a building on site, like the one shown in Figure 1.

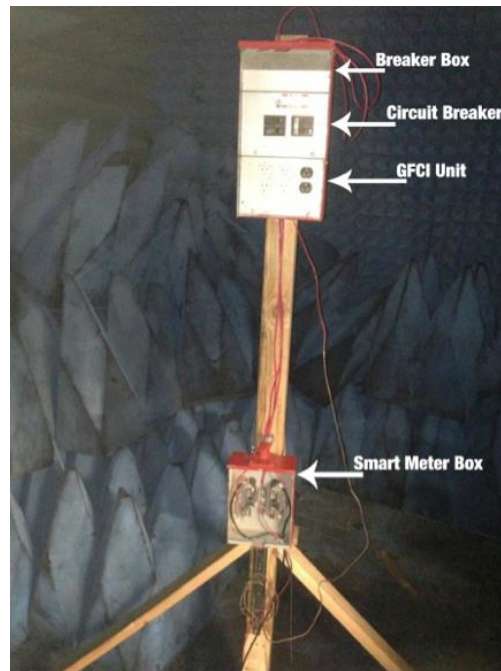

Figure 1-1 Laboratory setup representing a construction pole with GFCI electrical panel and vertically adjustable Smart Meter inside an anechoic chamber.

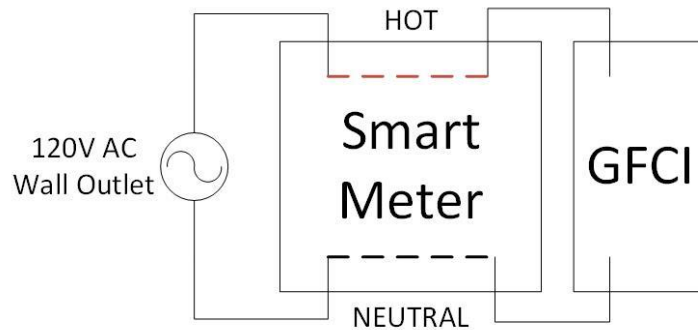

Figure 1-2 A simplified schematic of the test stand setup found in Figure 1-1. This depicts the operational scenario of a Smart Meter being powered from a 120V AC wall outlet, and then a GFCI being powered off of the hot and neutral AC bus of the Smart Meter's compartment box. Earth ground is not depicted here, but there is an earth ground bus within the Smart Meter box.

Smart Meters use wireless radio frequencies (RF) to transmit data back to the main data collection HUB of its respective electricity provider, and interact with other Smart Meters through a mesh network. This causes Smart Meters to send and receive transmissions hundreds, sometimes thousands of times per day. Through evidence observed both within the laboratory and at many construction sites, these transmissions have been found to interfere with GFCI outlets, producing uncontrollable problems for those using the two devices in close proximity to one another. Research and studies have been previously performed investigating similar interactions, however no conclusive results have been reported [8,9,10]. It should be noted that there have been no reported causes of this interference in homes where the Smart Meters are located a considerable distance away from the GFCI outlets. Instead, the main concern has come from installations on construction poles, such as the one in Figure 1, where the proximity between the meter and the GFCI is close, typically within 0.5 meters.

There are three likely sources of interference between the GFCI and the Smart Meter. First, the differential transformers found inside of GFCI devices have a voltage induced upon them through coupling of the RF transmission signals. Second, the RF signal is being unevenly induced on to the hot or neutral line. Thirdly, the RF signal is being induced through the power line shared by the Smart Meter and conductively radiated into the GFCI's electronic sense board. Any of these three scenarios could cause the GFCI to detect a faulty leakage current and trip. The goal of this research is to establish the reason for the faulty trips and to find a cheap and easily implementable solution to mitigating them.

1.1.2 Brief History of GFCIs

In 1955, a man named Henri Rubin developed a device that could prevent those who worked in South African mine from dying of ventricular fibrillation, or in other words death from electrocution. Initially, Rubin's fault detector had a sensitivity of 250 mA, something rather high when it comes to attempting to prevent someone from dying (for reference, a chart demonstrating the effects of electrical shock on humans can be found in Figure 1-2). This device was known as a "second-harmonic magnetic amplifier core-balancer", or magamp for short. Within a year, Rubin had improved his invention tremendously, creating a prototype rated at 220V and 60A with an adjustable sensitivity between 12.5 mA and 17.5 mA. He then filed for a patent in both South Africa and Australia. Although these magamps were used for safety within the South African mines, there were also mining towns that suffered from the same problems. After an accidental electrocution of a woman in the mining town of Stilfontein, magamps began to be installed in houses for safety purposes.

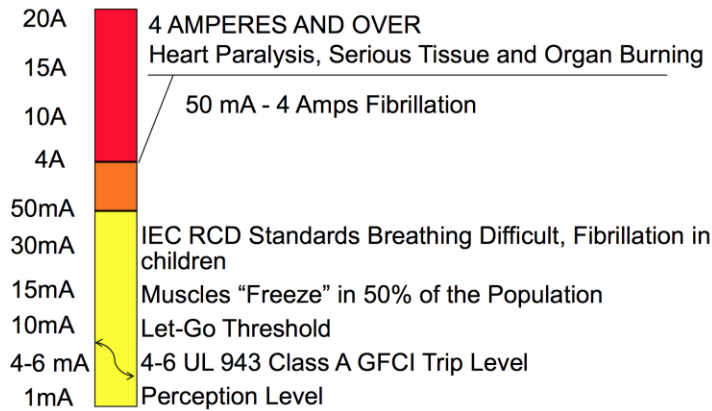

Figure 1-2 Effects of different amounts of current as a result of electrical shock on the human body. UL 943 lies between the perception level, in which a human can feel the electric shock, and the let-go threshold, which is right before muscles will “freeze” during electrocution not allowing a person to let go of whatever they’re gripping.

In 1961, a man named Charles F. Dalzeil developed a transistor version of the magamp. This is when the name Ground Fault Circuit Interrupter – or GFCI for short – was coined. Since then the device has improved over time with more regulations being applied, such as requirements for them to be installed in houses in any place where a water source is available. Deaths per year in electrocution began to decline as GFCI’s use became more widespread. The graphic in Figure 1-3 represents the number of deaths per year by electrocution compared to the number of GFCIs installed in households. Number of deaths began to be recorded in 1976 with roughly 650 deaths per year with just around 2 million GFCIs installed. By the year 2000, deaths per year were down to roughly 180.

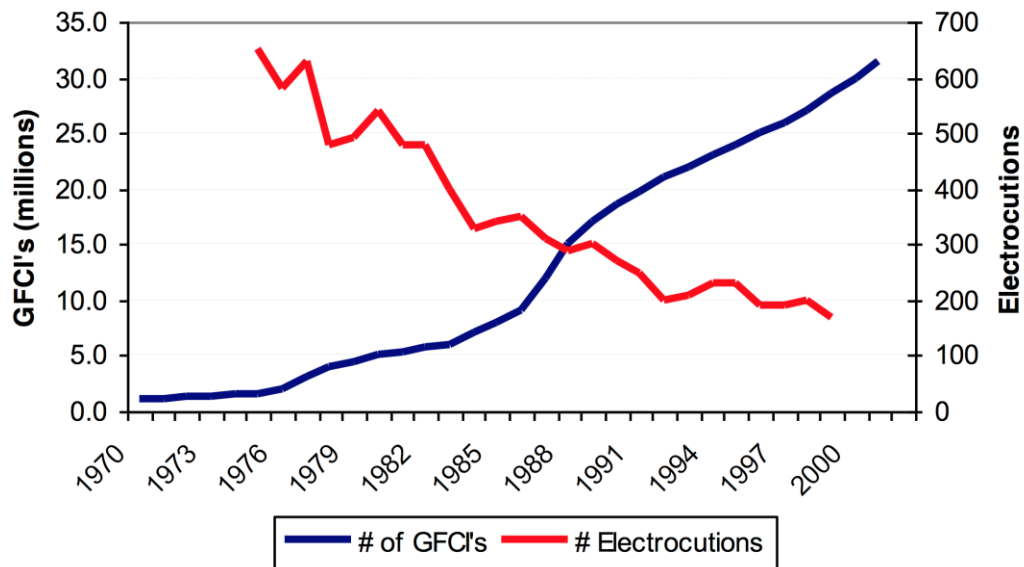

Figure 1-3 Number of deaths per year in the United States compared with the number of GFCI's installed in homes.

Chapter 2

Background

2.1 Basic GFCI Operation

To better understand the problem at hand, the basic operation of a ground fault circuit interrupter (GFCI) device will be outlined in this section. There are four different states that a GFCI may be in, including: normal operation, the test state in which a fault is produced on demand to test the device's integrity, ground fault operation in which a fault is detected between hot and neutral lines, and ground-neutral fault state when a fault is detected between neutral and earth ground.

2.1.1 Normal Operation

When a GFCI device is operating normally, there is no "fault" present in the system. This means that the same amount of current flowing through the transformer on the hot line to the load is also flowing back on the neutral line. In other words, the circuit is being completed with no foreign loads, or "faults", appearing and causing a tripping event. As can be seen in Figure 2-1, it states that equal current is flowing in and out of the transformer, and thus the "trip coil" remains deenergized. The trip coil is simply a solenoid controlled by an integrated circuit that receives an input from the transformer. When the signal is received from the transformer, the electronics will apply some current to the solenoid, disconnecting the forward path to the load and inhibiting any power flowing.

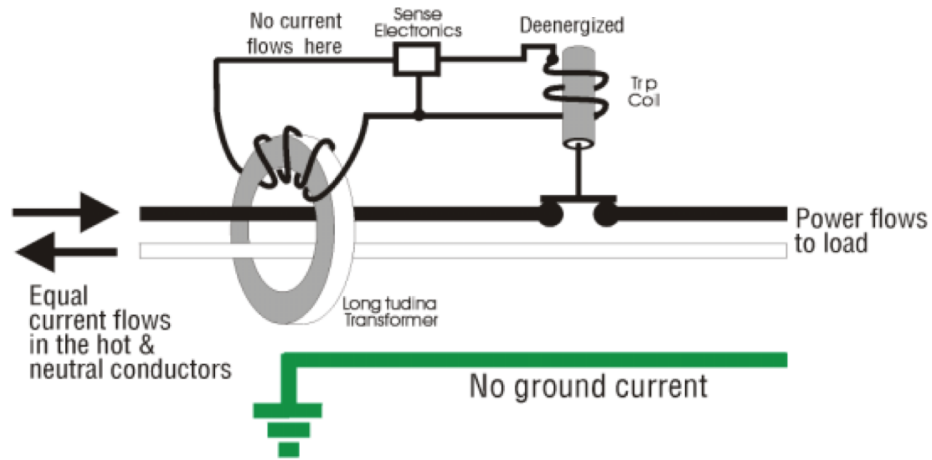

Figure 2-1 Basic GFCI operation with no fault current detected and equal current flowing through the forward path, into the connected load, and then back through the return path.

Since the same current is flowing in and out of the transformer there are no trips occurring. The black line is the “hot” (forward), and the white is the “neutral” (return).

2.1.2 Test Button State and Example

Each GFCI has a built in test button. The test button is something required by UL923 in order to allow for consumers to test their own devices for proper functionality. When the test button is pushed, a “ground fault” occurs and the GFCI disconnects any connected loads. The test button creates this fault by creating a connection and effectively applying a resistor between the hot and neutral lines. Because this connection is done before the transformer is introduced on the forward path (hot line) and before reaching the transformer on the return path (neutral line), a change in current is sensed. In short, a resistor affects the amount of current, the GFCI senses a current leak and the device trips. This scenario can be seen in Figure 2-2 for reference.

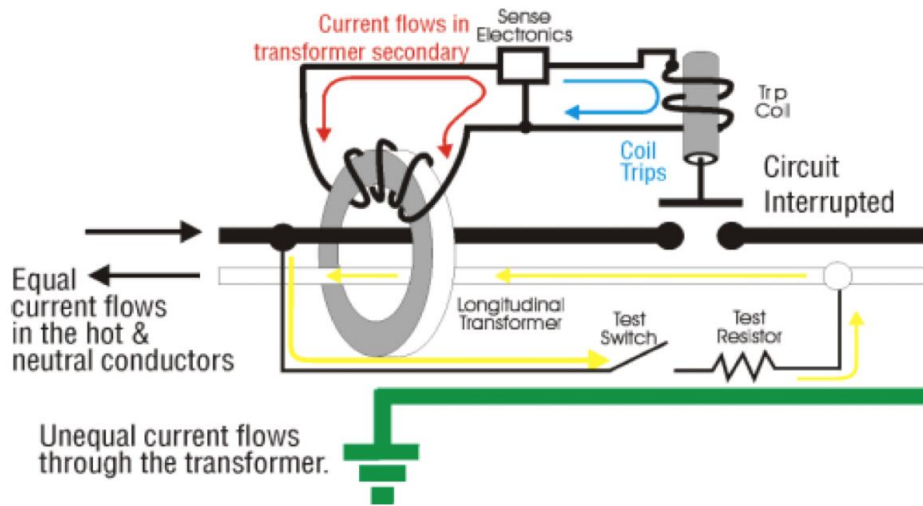

Figure 2-2 Test button operation of a GFCI unit. In this scenario, the test button of a GFCI has been pressed. This introduces a “test resistor” to the circuit between the hot and neutral lines. Since the current is no longer equally flowing in and out of the transformer, the transformer will send an input to the sense electronics which will then disconnect the hot line.

2.1.3 Ground Fault Occurrence

Assuming a GFCI is operating correctly, it is capable of producing a “ground fault”, as discussed in the previous section. This will occur when a foreign load is introduced to the circuit, connected between the hot line and the earth ground. When this event takes place, some amount of current will flow through the foreign load rather than back through the neutral line. Since there is a difference between the current flowing on both lines through the transformer, the sense electronics will receive an input and activate the trip coil. The coil will disconnect the hot line from the foreign load in attempt to prevent any damage from occurring. There are a few specifications required by UL943 (which will be discussed later) regarding the tripping requirements and trip time for a

Class A GFCI. Many other specifications are required, but these are generally the ones that someone might be concerned with as it could be the difference in saving a life from electrocution. As mentioned earlier, according to UL943 a Class A GFCI is required to trip when a 6 mA fault occurs and it must produce this trip event within 6 ms. A ground fault scenario can be found depicted in Figure 2-3, in which a person has connected themselves between the hot line and earth ground, creating a foreign load and misaligning the current flowing through the GFCI.

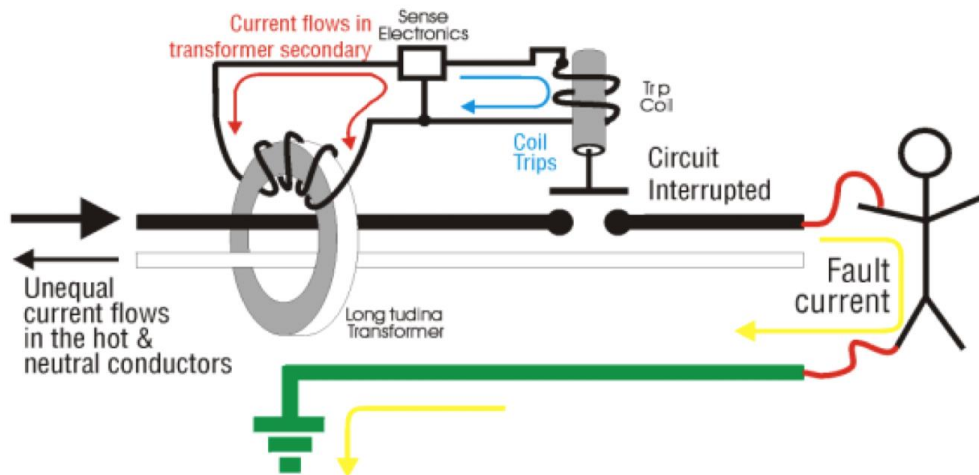

Figure 2-3 A scenario in which a GFCI has experienced a tripping event. A foreign load has been introduced between the hot line and earth ground. Instead of current flowing through the neutral line return path, the current now flows to ground. When this occurs, the amount of current flowing in and out of the transformer is not equal, causing it to send an input to the sense electronics, which then disconnect the load.

2.1.4 Ground Neutral Fault Occurrence

A ground-neutral fault is a special case in which a fault occurs between the neutral line and earth ground. There are two differential transformers found in GFCIs: a

hot-neutral transformer and a ground-neutral transformer. In the previous figures depicting different operational scenarios there is a hot-neutral transformer, which is the one that most people are familiar with. However, what happens if a person accidentally connects themselves between the neutral and earth ground? At first glance, it seems like the same scenario would occur as in Figure 2-3. If a person has attached themselves between neutral and earth ground, then the amount of current flowing in and out of the transformer should be different and trip. This is true, but the sensitivity of the transformer may not be high enough to actually activate the trip coil and disconnect the load. Due to this being potentially dangerous, a separate, more sensitive coil is used to detect this even. This coil still contains both the hot and neutral lines, has a more sensitive winding configuration, and is connected to another input of the sense electronics. Note that in the figures above the neutral coil is not depicted, so for reference this scenario can be seen in Figure 2-4.

Since a ground-neutral fault is based on a slightly more complex situation, an example will now be given. This example can be followed by looking at Figure 2-4. Say a load is connected to the GFCI unit as normal, but on the neutral side of the load there is a fault going to ground. Then, say a person connects themselves between the hot side of the load and earth ground. This is the exactly same thing as a regular ground fault, meaning when a 6 mA differential is detected the GFCI should trip. When this happens, current will go through the person and back through the fault and on to the return path. Current traveling back down the return path now is different than the forward path, but since there is also a fault between neutral and earth ground the 6 mA will change to a lower current due to a higher impedance load being introduced into the system. This will cause the GFCI to not trip since the 6 mA threshold isn't reached, but electrocution is still

occurring. To remedy this problem another transformer is deployed with a different sensitivity in order to disconnect the load when this occurs.

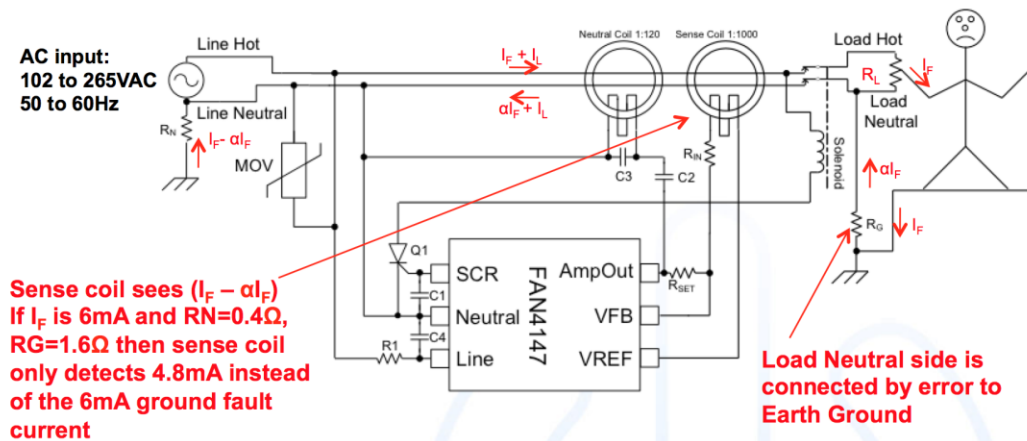

Figure 2-4 A scenario in which a GFCI has experienced a tripping event. A foreign load has been introduced between the hot line and earth ground. Instead of current flowing through the neutral line return path, the current now flows to ground. When this occurs, the amount of current flowing in and out of the transformer is not equal, causing it to send an input to the sense electronics, which then disconnect the load.

2.2 Basic Smart Meter Operation

Smart meter's operate on a very basic principal, though many of the finer details remain unknown. What is known, however, is that a Smart Meter network is much more complicated than most believe. Generally, there are "nodes" found in neighborhoods, or in a relatively large area where Smart Meters are deployed. These nodes are what actually communicate with power and utility companies regarding a home's power usage. Typically, only one transceiver is found in Smart Meters, but recently with the "internet of things" craze happening, two transceivers are sometimes seen. In the case of the Smart Meter used for this research, two transceivers are found. First, a proprietary 902-928 MHz RF transceiver is used as the primary means of transmission when it comes to communicating between the power company and the household. Smart meter's create what is called a "mesh network". If a certain Smart Meter is not able to locate the nearest

node it will transmit its data to the closest Smart Meter. The ability of devices to be able to communicate with each other directly, rather than through a central node, is what makes the “mesh”. From here, the next Smart Meter will either be able to reach the closest node, or simply pass it along to the next Smart Meter. This process repeats until the node is in range and the information reaches its destination. While this is a solution to having long distance communication between power companies and homes, this also means that Smart Meters can potentially transmit hundreds, if not thousands, time per day. [13]

Secondly, a 2.4 GHz ZigBee transceiver is also present, but is by default not active. The ZigBee’s purpose is to connect to other devices in households in order to gather information about how much power is being used individually. By doing this, consumers can use an app or website to check on which devices consume the most power in their house in attempt to help them save money.



Figure 2-5 A Landis+Gyr FOCUS AXR-SD 120V Smart Meter, used in all tests throughout this study.

2.3 Possible Causes of Tripping

As mentioned earlier, there were thought to be three possible sources of interference between the GFCIs and the Smart Meter. The initial thought was that the differential transformers used for the sense coil and the ground-neutral coil may have some voltage induced on them through radiative coupling of the RF transmissions of the Smart Meter. In other words, the electromagnetic field produced by the RF signals was affecting the device in such a way that either the sense electronics or the solenoid itself was being affected enough to cause a tripping event. At the same time, since an RF signal produces an electromagnetic field, the magnetic field portion could also be affecting the transformer. A differential transformer will create its own magnetic field when current is applied to them as described by Ampere's Law:

$$B = \mu nI \quad (2)$$

in which μ is the magnetic permeability of the medium, n is the number of turns per unit length in the solenoid, and I is the conduction current which together result in B - the magnetic field. In this equation, the permeability and number of turns are always constant, so if the magnetic field is being manipulated then the current must be increasing. By changing the magnetic field within the transformer, it can affect the circuit in the same way as a normal current imbalance would. Also, this same concept can be applied to the armature solenoid which physically disconnects the load from the GFCI receptacle, as can be seen in Figure 2-5.

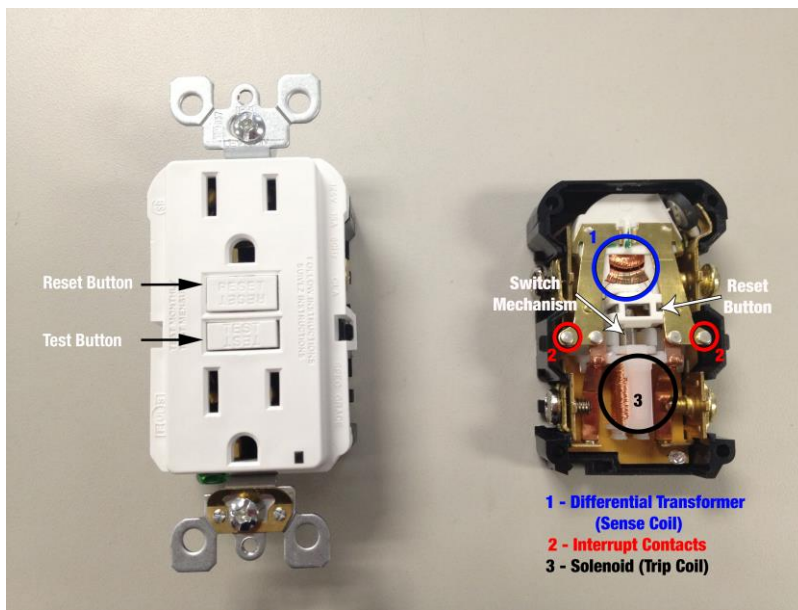

Figure 2-6 The basic internal components of a GFCI unit. The Switch Mechanism armature can be seen protruding itself from the solenoid, the Interrupt Contacts are the actual contacts that are physically disconnect in the event of a trip, and the differential transformers including the sense coil and the ground-neutral coil.

Secondly, a possible cause could be that the Smart Meter's RF signal is being induced into the power line shared by the Smart Meter and GFCI, and then conductively coupled into the GFCI's electronic sense board. This could potentially cause an uneven current to pass through the differential transformers, causing a trip event. Conductive coupling could also somehow find its way into the differential transformers or solenoid, which then trips the device.

2.4 Previous Work

While no real tests have been previously performed investigating the interaction of Smart Meters and GFCIs, some research has been done investigating the RF transmissions of Smart Meters. [14,15] In 1976, just one year after the United States began to require them in bathrooms of homes [10], Construction Engineering Research Laboratory in published research investigating the many different ways of tripping a GFCI device. Among those studied were radio frequency interference (RFI) and ultra-high frequency (UHF) microwave interference. However, being 30 years ago this information is outdated and recent GFCI designs have built in protection against most RF interference.

While the Smart Meter and GFCI device interaction is not well understood, there is a similar problem that is still common in homes today. In this case, the culprit is when a GFCI is paired with a hot tub. An adjustable-speed drive (ASD) is a device used in hot tubs or spas which varies the speed of the pump machinery used. In the study "Compatibility Between GFCI Breakers and Household Adjustable Speed Drives" by Kimball *et al.* the frequency response of a GFCI is compared to that of an ASD commonly found in hot tubs. [17] This device is classified by the FCC to be a class B digital device, meaning it's for use in a residential environment, and is an unintentional radiator. Within the ASD is a two-stage EMI filter, which can be seen in Figure 2-6. It was mentioned that

“The radiated emissions of a class B unintentional radiator are restricted for the frequency range of 30 MHz to 960 MHz, and beyond, where the EMI filter in question has little impact.” [17] It was also noted that the conducted emissions are restricted to 150 kHz to 30 MHz While a solution to the higher frequency signals tripping GFCIs was not found by Kimball, it does further suggest that a problem exists between the two. This paper, along with common electronics knowledge, suggests that a filter would be a good solution to prevent any interference between the Smart Meter’s RF transmissions and the GFCI tripping, but would not be practical enough for this particular application.

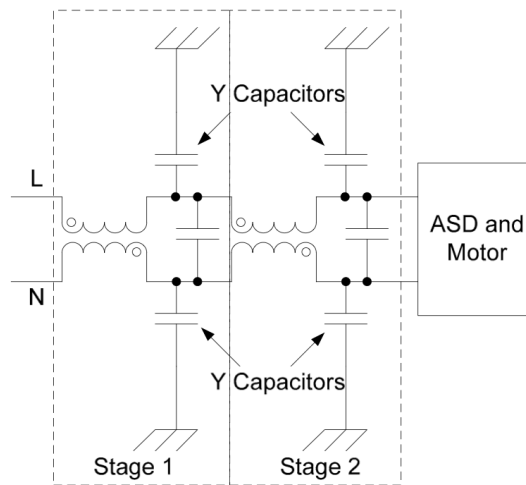

Figure 2-7 The two-stage filter found on adjustable speed drives used in hot tubs for mechanical regulation of their pumps. This is what is typically found within ASDs to prevent GFCI devices from tripping at the frequencies they generate.

One of the initial thoughts on potential causes of tripping was that the Smart Meter’s RF transmissions were interfering with the GFCI electronics radiatively. Combined with information provided by the construction sites that some workers would flip the GFCI receptacles upside-down hinted that there could be a “hot spot” in the

electromagnetic field that was strong enough to cause more frequent tripping. If orientating the GFCI in a different way would sometimes relieve it of tripping, then conductive coupling seemed less likely. Due to this thought, some research into previously done studies on the fields created by Smart Meter RF transmissions was done. Most of the studies found were from health fanatics claiming that RF transmissions are hurting them and giving them headaches, but there were two that stood out. First, a thesis which did electric field measurements at different distances from the Smart Meter in attempt to characterize the emissions. This study pretty much described exactly what anyone could infer: the closer you are to the Smart Meter the stronger the field becomes, as can be seen in Figure 2-8.

The second study gave a much more in-depth look into the matter. The Electric Power Research Institute (EPRI) investigated a report done by the Sage Associates, a healthcare consulting company. [14,15] Sage Associates claimed that Smart Meter's RF transmissions could potentially harm residents, comparing them with tables of FCC violations regarding wireless transmissions and the health hazards associated with them. Skeptical, EPRI did their own study and found conflicting information, effectively debunking the claim that Smart Meter's RF fields are dangerous to one's health. While this paper isn't concerned with health risks, EPRI mapped the three-dimensional field created by transmissions.

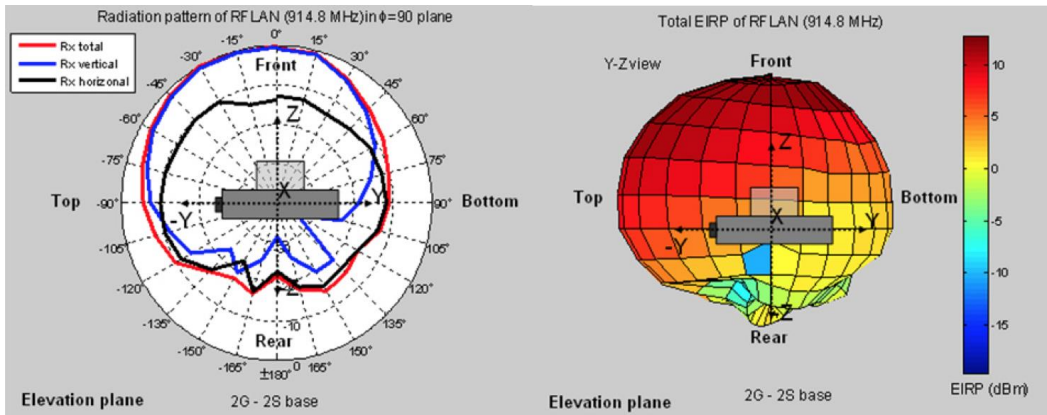

Figure 2-8 Three-dimensional field of Smart Meter RF transmissions created by EPRI.

Note that between the 45° and 0° mark the field is higher intensity in both horizontal and vertical directions when facing the Smart Meter.

This gave some insight supporting the suspicion that there could be a “hot spot” in the emission pattern. EPRI’s three-dimensional map can be seen in Figure 2-8 and a slight protrusion of the field is noted around the negative 45-degree mark.

Chapter 3

Experimental Design and Procedure

3.1 Experiments

3.1.1 Transmission Field Mapping

In order to better quantify the electromagnetic field strength of the Smart Meter's RF transmissions, the electric and magnetic fields generated by the Smart Meter were mapped as a function of distance and angular position around the meter. The angle reference used is shown in Figure 3-1. The Smart Meter was positioned on a rotating platform and both the electric and magnetic fields were measured as a function of angle and distance away from the meter using field probes made by Beehive Electronics [18]. The output of each probe was measured using its own dedicated Agilent ESA 4403B 3GHz spectrum analyzer. First, measurements were made with the center of the Smart Meter located 4.9 cm away from the center of the GFCI unit. The experiments were performed within an RF shielded room in order to eliminate any outside interference.

Angles in 45-degree intervals were marked on to the rotary table, along with a reference point for the Smart Meter to be placed upon. For reference, the angle placement in relation to the Smart Meter can be found in Figure 3-1 above. If the Smart Meter were a circle on an x and y-axis, then the reference point would be the 0-degree mark on the right hand x-axis. This allowed for the Smart Meter to be rotated and measurements to be taken at the various angles reliably and repeatedly. Both spectrum analyzers utilized a GPIB to USB connection, allowing them to interface with a National Instruments LabVIEW measurement program.



Figure 3-1 Angles marked on the Smart Meter for reference as to where measurements were taken in relation to position on the rotary table.

A custom LabVIEW Visual Instrument (VI) was created for data capture across the 900 to 930MHz spectrum. The field's strengths were recorded for two minutes at each 1.25 cm distance interval. During that time, the program captures data upon a trigger of -40 dBm. This is due to the minimum RF transmission power from the maximum distance tested being, on average, -40 dBm. It is worth noting that the Smart Meter's RF emission strength varies as it tries to connect with a communication HUB, which is not located within communications length of the meter. This caused variation in the measurements over the two-minute period. The highest intensity pulse recorded over the two-minute test period was used in the mapping of the magnetic field (B) and electric field (E) from 0 to 90 degrees relative to the reference point. Those plots are shown in Figures 3 and 4 respectively. Note that these measurements are subject to the time in which they were taken and may vary, though multiple readings were taken to minimize potential error. It can be seen in both figures that there is a 'hot spot' observed around the 45-

degree angle of the Smart Meter. The intensity of the field remains relatively constant up until 4.7 cm, at which point it changes by roughly 10 dBm. It may trip more often when subject to the “hot spot” of the fields. A map of the B-field can be found in Figure 3-2 and the E-field in Figure 3-3. The results show that the orientation of the Smart Meter with respect to the GFCI may impact the coupling of RF into the GFCI's electronics. It may suggest that orientation of the meter on the construction stand could prevent any tripping from occurring.

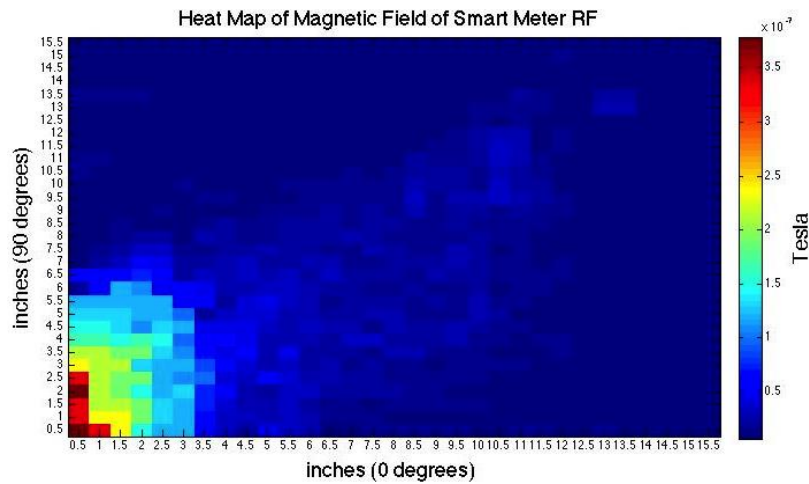

Figure 3-2 B-field measured axially for varying distances between 0 and 90 degrees.

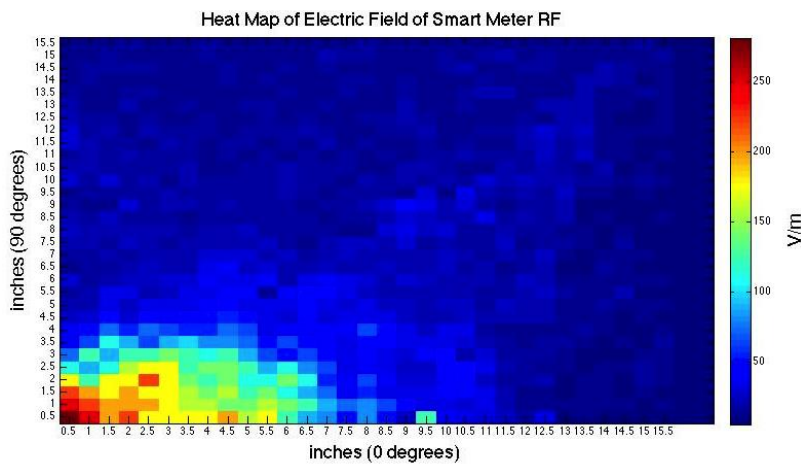

Figure 3-3 E-field measured axially for varying distances between 0 and 90 degrees.

It is important to note that the magnitude of both B-field and E-field shown in the graphs were derived from the data sheet of the Beehive probes. The pure data measured by the spectrum analyzer was in Decibel-milliwatts (dBm), which was then converted to Tesla (T, Equation 3) and Volts per meter (V/m, Equation 4). For reference, the graph of the field created by using the dBm data is much more vibrant and is much more clear as to where the hotspot is located compared to the other two plots. This can be found in Figure 3-4. Unfortunately, the dBm plot for the E-field is not available. The two equations for conversion are the following [18]:

$$B - \text{field Probe: } P_{out} = X + 20 \log_{10} B + 20 \log_{10} F \quad (3)$$

$$E - \text{field Probe: } P_{out} = -113.2 + 20 \log_{10} E + \log_{10} F \quad (4)$$

A loop probe is used for the B-field, and the stud probe for the E-field. In this case, the P_{out} term is in dBm, F is the frequency of the received signal, and the terms being solved for are B and E - the B-field in terms of Tesla and E-field in terms of Volts per meter. In the loop probe equation, the X term (in this case is 65.2) is decided by which size loop is being used. For this study, the medium sized loop was used due to the frequency of the signal being between close to 1 GHz, and thus according to the data sheet was the best fit.

3.1.2 Differential Transformer Measurements with Load (Distance Testing)

Initially, testing for tripping was done by applying a load to a modified GFCI in which sense wire leads were soldered on to the differential transformer. Since a transformer detects a change in current, there must also be a change in voltage. The thought was that perhaps there could be a voltage threshold identified when measuring trips. However, a load had to be applied because otherwise measuring the differential transformer with the oscilloscope would immediately trip the device.

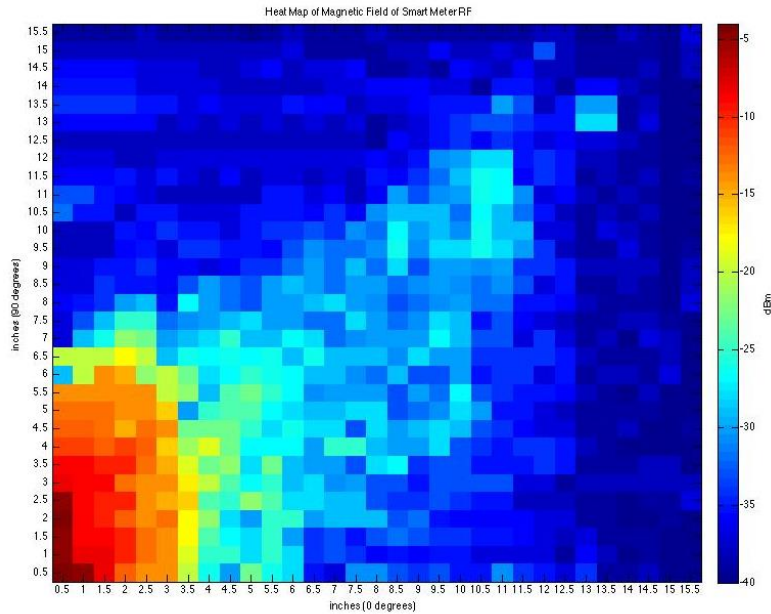

Figure 3-4 B-field measured axially in terms of dBm for varying distances between 0 and 90 degrees. This representation more clearly depicts the field’s “hotspot” being emitted by the Smart Meter at roughly the 45-degree mark.

The experimental setup for this test can be found in Figure 3-5, which depicts both a modified and unmodified GFCI of the same model. The modified GFCI has leads soldered on the terminals of both the neutral and sense coils (both differential transformers), and there is a B-field probe placed directly beside the location of said transformers, between both GFCIs. In this case, Measurements were done off of the sense transformer, which detects faults between hot and neutral.

With this setup, it was thought that perhaps if the Smart Meter was moved far enough away from the GFCIs that the tripping would stop. If tripping did stop all together, then the interference would have to be radiative.

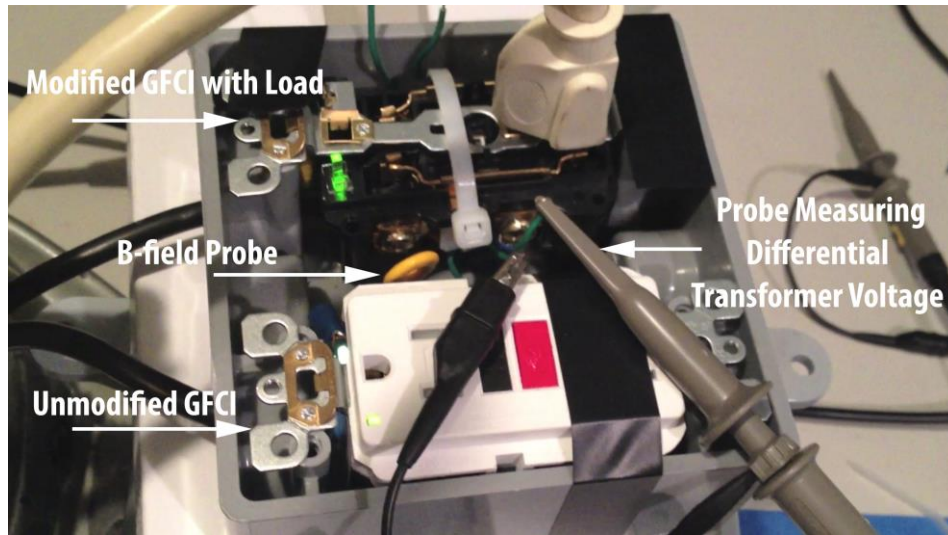

Figure 3-5 Experimental setup with both modified and unmodified control GFCI. The load is plugged into the modified GFCI in order to measure the differential transformer voltage without tripping, and a B-field probe is placed directly next to the transformer located in each device.

Since the placement of the GFCI in relation to the Smart Meter when installed on the construction stand is roughly 0.3 meters from center to center, this was the initial distance they were tested at. A strip of tape was stuck to the table and marked with measurements for reference, as can be seen in Figure 3-1. From here, increments of one inch were made starting at 12 inches and ending at 15 inches. The peaks of the voltage waveforms from the differential transformer were taken at both normal operation and during transmission of the Smart Meter, but only if a trip occurred. This ensured that if there is a relation between the RF transmissions and the transformer, then it would appear in the measurement data.

3.1.3 Operation using Circuit Isolation

One hypothesis to explain the unexpected tripping events is that the shared power line conducts the RF signal from the meter into the GFCI electronics. In order to test the validity of this hypothesis, the two circuits must be electrically isolated as much as possible while still leaving them in normal operating modes. In the laboratory, two similar GFCIs, made by different manufacturers, and a single 120 VAC Smart Meter were each powered using a separate AC power source.

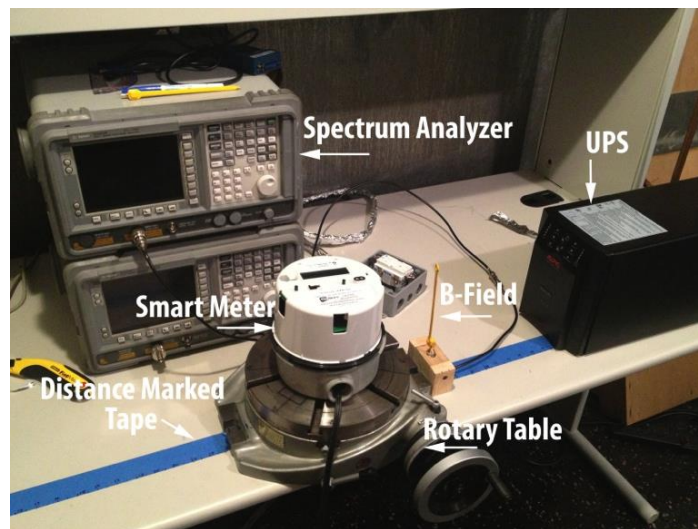

Figure 3-5 Experimental setup consisting of a 120V Smart Meter, B-field and E-field probes, UPS, two spectrum analyzers, and GFCI outlet box.

Since the outlets within a room are typically on the same circuit, plugging each in to a wall outlet would not sufficiently isolate the two devices. Instead, an APC Smart-UPS SUA 1500 uninterruptable power supply (UPS), unplugged from the wall, was used to power the two different brands of GFCIs while the Smart Meter was plugged in to a normal wall outlet. This experimental setup is the same as that shown in Figure 3-5 above. During the experiments, the GFCIs, regardless of brand or model, still tripped repeatedly despite not being on the same circuit as the Smart Meter. This eliminated the

theory that the only source of RF interference is from that directly induced on the power line connecting the Smart Meter and the GFCI. Instead, this suggests that RF is either directly coupled into the GFCI outlet, or the power line leading up to the GFCI acts as an antenna that picks up the RF and conducts it into the GFCI.

3.1.4 Differential Transformer Measurements without Load

Once there was evidence of the RF being wirelessly induced into the GFCI, a second test was setup in order to more accurately simulate the orientation of the GFCI outlet in relation to the Smart Meter. Since the distance between the two centers of the devices on the test stand was measured to be 31.75 cm, this was the distance used to separate them. Additionally, measurements of the voltage across the differential transformer were made. This was accomplished by simply soldering leads on to the designated terminals of the GFCI's PCB. Utilizing the mapping of the electric and magnetic fields shown earlier, the GFCI was positioned such that it was oriented at a 45-degree angle, exposing it to the 'hot spot'.

The wires were soldered to the test points of the differential current transformer and ground to neutral sense coil on the GFCI's printed circuit board (PCB). Initially, it was found that if differential voltage probes were connected to both the differential current sense coil and the ground to neutral sense coil, the GFCIs would immediately trip once connected to the oscilloscope and they could not be maintained in a non-tripped state. In normal operation, a trip event cuts power to the uneven load, removing the condition on the coil, which induced the trip event to begin with. This type of normal operation is illustrated in Figure 2-1. In the laboratory experiments, the trip event is not induced by actual imbalance in the load and therefore the condition, which causes the trip, continues even after the internal solenoid has been activated. Instead the solenoid is repeatedly activated causing a steady current flow through it, which melts the solenoid within

seconds since it is not designed for continuous current flow. In order to solve this problem, an isolation transformer was used to power the oscilloscope and to isolate its power from earth ground. This effectively “floats” the oscilloscope, but allows measurements to be taken from the GFCI without any ground bouncing occurring.

Chapter 4

Experimental Results

4.1 Distance Testing Results (with Load)

It had been hypothesized that one possible solution that would be easy to implement on construction sites would be to simply move the Smart Meter farther away from the GFCI outlet box on the construction pole. Since the distance between the GFCI unit and Smart Meter on a construction pole is roughly 31.75 cm (12.5 inches), the starting point for this test is 30.48 cm (12 inches).

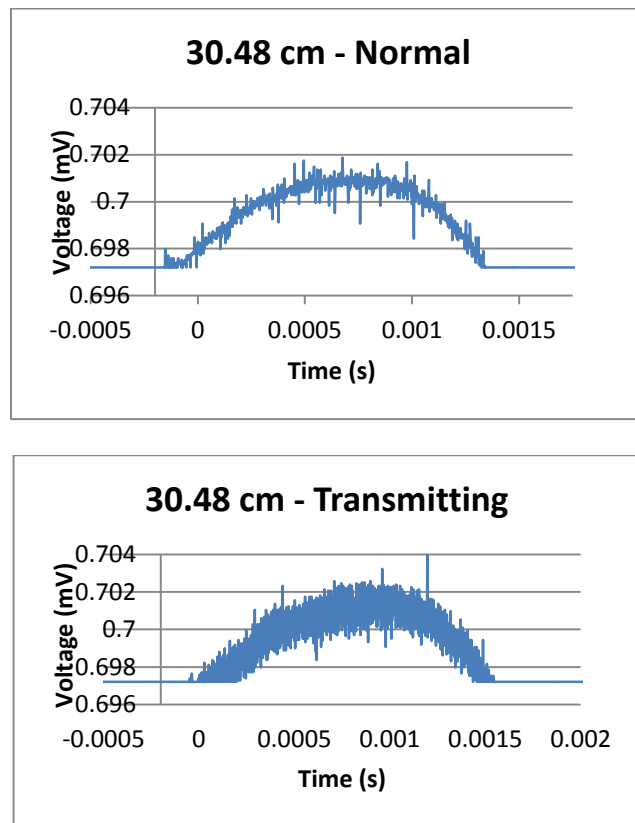

Figure 4-1 These are the peaks of the load being applied (100W light bulb) to the modified GFCI at 30.48 cm (12 inches) during regular operation and during a trip while the Smart Meter was transmitting.

From here, testing was done in intervals of 2.54 cm, or 1 inch. A 100W light bulb was used as a load in these tests, allowing for a comparison of the waveform both during normal operation and during an RF transmission from the Smart Meter. In Figure 4-1, it can be seen that a large amount of interference is induced on the coil and measured during a trip at the same time as a Smart Meter RF transmission occurs. The peak of the waveform during transmission is approximately 0.702 V (though there is a moment when 0.704 V is recorded) and the peak during normal operation is approximately 0.701 V. This resulted in an approximate 0.0013 V differential.

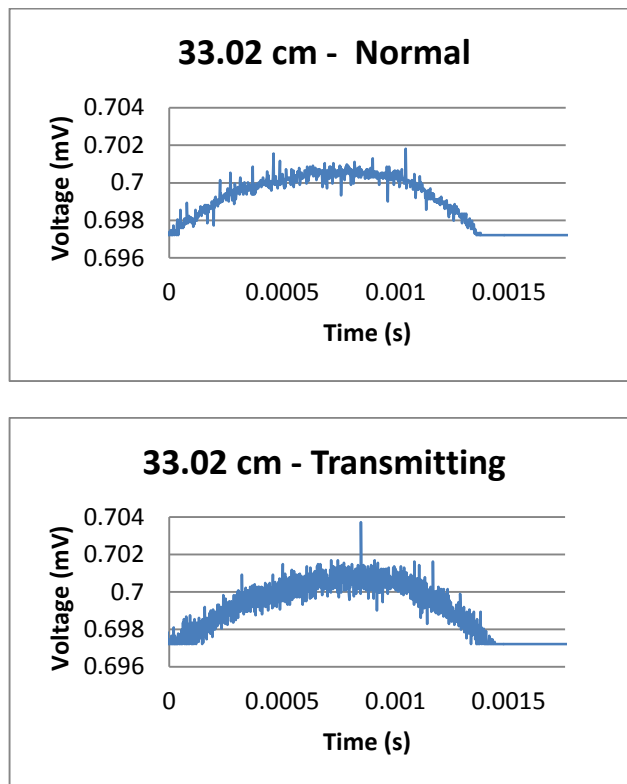

Figure 4-2 These are the peaks of the load being applied (100W light bulb) to the modified GFCI at 33.02 cm (13 inches) during regular operation and during a trip while the Smart Meter was transmitting.

Next, the GFCI receptacle was moved one inch further away with respect to the center of the meter as a whole. The hope was that the interference would lessen as the distance increases. For the 33.02 cm interval, the approximate transmission peak is 0.7015 V and the approximate peak during normal operation is 0.7008 V, resulting in a differential of 0.0007 V. While this is less, there is still substantial interference, and the differential is likely within the error of the measurement. Results for this test can be found in Figure 4-2.

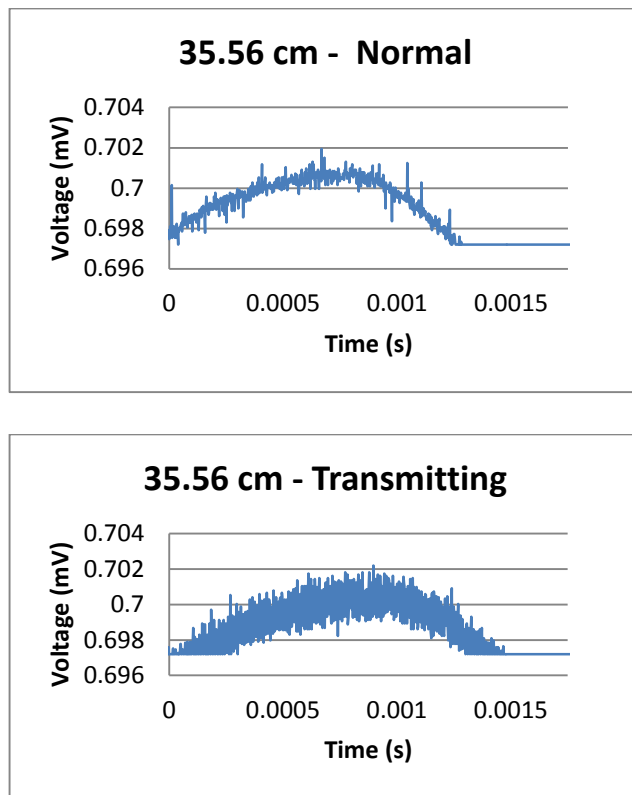

Figure 4-3 Peaks of the waveform of the load being applied (100W light bulb) to the modified GFCI at 35.56 cm (14 inches) during regular operation and during a trip while the Smart Meter was transmitting.

Measurements at 35.56 cm, as seen in Figure 4-3, are roughly the same as those seen at 33.02 cm. The transmitting peak of the signal is at 0.7016 V and the normal operating peak is at 0.7009 V, with the differential again being 0.00704 V. As mentioned above, the wavelength of the wave at roughly 900 MHz likely has a much lower amplitude at this point when using the Smart Meter as a reference for the start of the wave.

Distance testing at 38.1 cm resulted in an approximate transmitting peak of 0.7017 V, an approximate normal operating peak of 0.7011 V, and a differential of 0.00064 V. Compared to the other tests, this was slightly lower than the previous two tests and more than half the differential of the initial 30.48 cm test. Results can be seen in Figure 4-4 below. A summary table containing the approximate transmitting and normal operating peaks of each distance, as well as the differential, can be found in Table 1.

Once regular distance testing was finished, the Smart Meter was then installed using an adjustable sliding rail system on the construction pole. Using this method, the meter was adjustable vertically along the pole with some degree of ease and control. The Smart Meter was adjusted to the maximum allowable distance (roughly 1 meter) from the GFCI. This was done with the idea that if the GFCI would trip when the Smart Meter was at the maximum distance of the rail system then it wasn't worth testing for a distance threshold since it wasn't able to be moved any further.

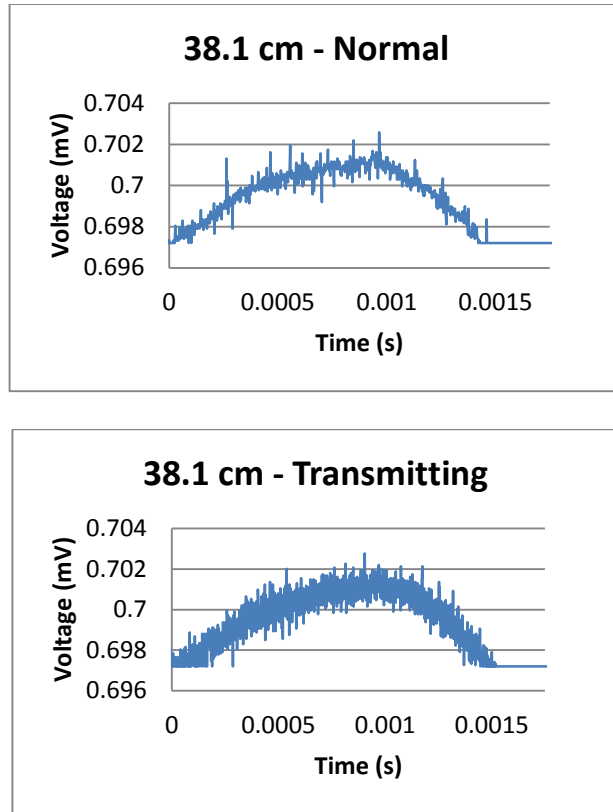

Figure 4-4 These are the peaks of the load being applied (100W light bulb) to the modified GFCI at 38.10 cm (15 inches) during regular operation and during a trip while the Smart Meter was transmitting.

Once the system was powered on, the GFCI tripped within 30 seconds. Because of this occurrence, it was concluded that the maximum allowable distance between the two devices is not enough to fully prevent tripping events ruling out movement of the meter farther away as a possible solution. Although possibly moving the Smart Meter far enough away that the wavelength of the RF transmissions might not interfere with the GFCIs, this was too trivial to provide as a solution. Also, keep in mind that the power of each transmission is never the same. When the device is left off for a long period of time and then turned on again, the first few minutes of transmissions attempting to connect to

a nearby network are much stronger than the periodic pings thereafter. In order to be as consistent as possible, the device was turned off for thirty minutes in between each subsequent test, but since data was only measured during trips (and trips didn't always occur right away), different transmissions during the trips inevitably had different signal strength.

Table 4-1 The approximate transmitting peak, normal operating peak, and the differential between the two when comparing GFCI differential transformer measurements at different distances.

~Centimeters (cm)	Approx. Transmit Peak (V)	Approx. Normal Peak (V)	Difference (V)
30.48	0.702584	0.70124	0.001344
33.02	0.701496	0.700792	0.000704
35.56	0.701624	0.70092	0.000704
38.10	0.701752	0.701112	0.00064

4.2 Results – Non-UPS Experiments

Waveforms measured across the differential transformer, when the GFCI was connected directly to the Smart Meter, are shown in Figure 4-1, and the waveforms measured across the ground-neutral transformer can be seen in Figure 4-2. In each plot, the pink waveform notates the “baseline” measurement taken while no RF interference was present and the GFCI devices were operating normally. This clearly shows the difference in voltage on both differential transformers at the same time an RF transmission occurs.

The green, blue and red waveforms show tripping events from three different experiments, each corresponding with their respective color on both plots. Figure 4-1 is a particularly good example of the RF interfering with the differential transformer voltage. When the RF transmission occurs at the 0 seconds point of the x-axis, a spike in voltage

is recorded, and at that same moment the GFCI tripped. This is definitive evidence of RF transmissions affecting GFCIs. The same occurrence happens with the ground-neutral transformer in Figure 4-2.

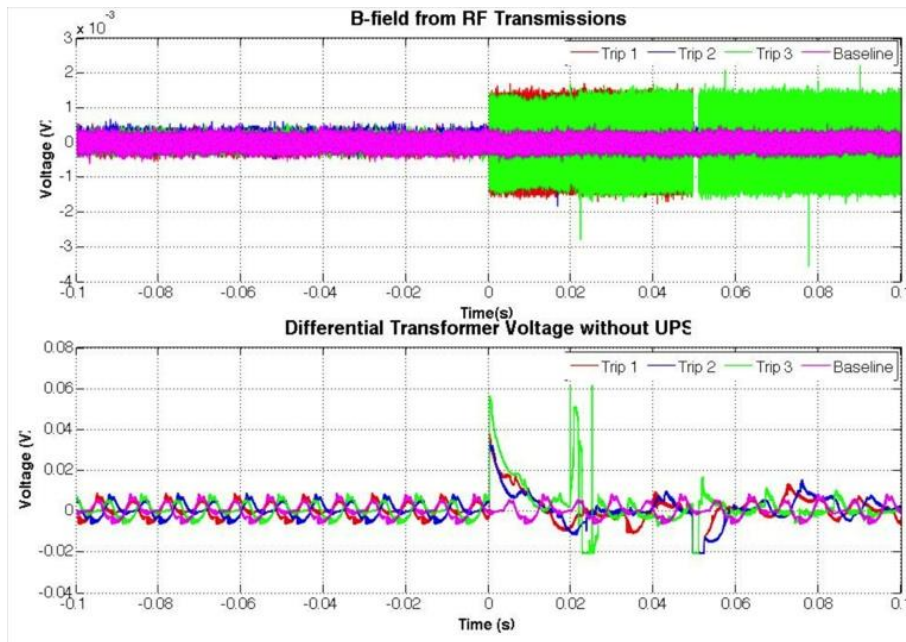

Figure 4-1 Tripping event measured across the differential transformer. Top: B-field measured from RF transmissions of the Smart Meter, Bottom: differential transformer voltage measured across the same time span as the RF transmissions. Each color of the RF transmissions corresponds with the differential voltage waveform colors.

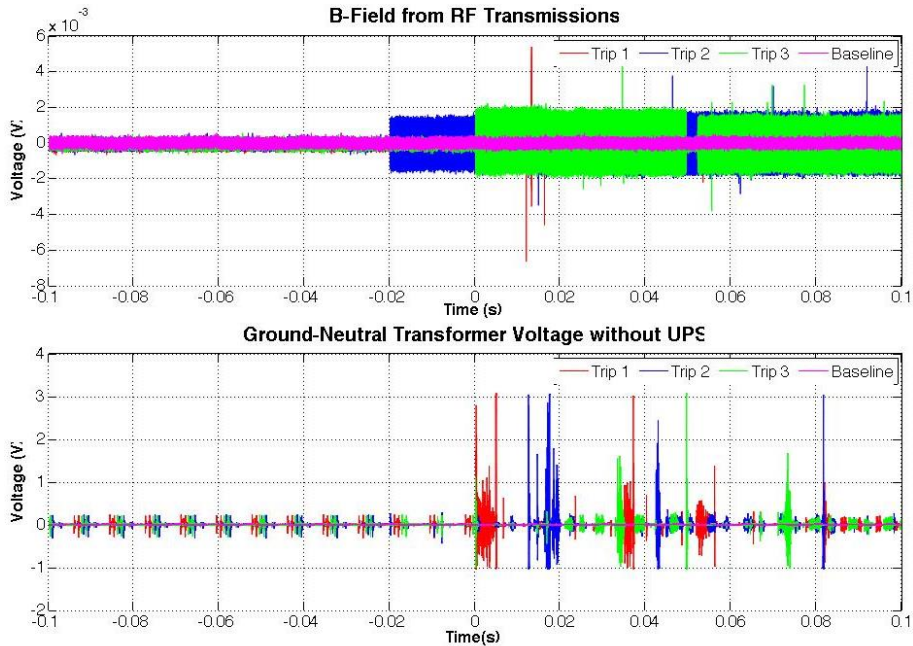

Figure 4-2 Tripping event of ground-neutral transformer. Top: b-field created from RF transmissions of Smart Meter, Bottom: ground-neutral transformer voltage during the same time span as the RF transmissions. Each color of the RF transmissions corresponds with the ground-neutral voltage waveforms of the same color.

The maximum voltage recorded on the differential transformer is around 60 mV, while voltages as high as 3 V were recorded across the ground-neutral coil. These higher voltages are due to the winding ratio on each transformer being different, 100:1 for the differential transformer and 1000:1 for the ground-neutral transformer. It can be seen that perturbations measured across the ground-neutral coil's voltage are much more frequent due to the higher turns ratio and therefore sensitivity. Even slight changes in the RF transmissions are picked up much more frequently in the form of voltage spikes on the coil. Each spike of voltage on the transformer is due to another RF transmission happening, but since they are overlaid for comparison they aren't completely visible.

4.3 Results – UPS Experiments

The previous experiments clearly show that RF transmissions affect GFCI devices due to their influence on the transformers, dictating whether a tripping event should occur or not. However, it does not dictate whether or not this interference is conductive, radiative, or both. By utilizing a UPS, the GFCI can be isolated from the Smart Meter on a completely separate power supply. If no trip occurs, it can be concluded that any interference must not be purely conductive. Note that this does not mean that there is no conductive interference through the Smart Meter's PCB. This test is used to confirm whether or not at least a portion of the interference is radiative as opposed to purely conductive. There may very well be multiple sources of interference affecting the GFCIs and causing tripping events.

Again, each of these tests had three tripping events recorded and a baseline to show the difference in voltage during RF transmissions of the Smart Meter. The differential transformer and ground-neutral transformer were both tested independently of each other. The waveforms measured across the differential transformer can be found in Figure 4-3, and those measured across the ground-neutral transformer can be seen in Figure 4-4. As seen in these figures, tripping events occurred similar to those seen earlier.

One interesting note is the rapid occurrence of transmissions occurring when the voltages were measured across the ground-neutral coil. During that test, they were occurring so rapidly and since the scope was manually triggered during measurement of the ground-neutral coil, many spikes are observed before the trigger event occurs.

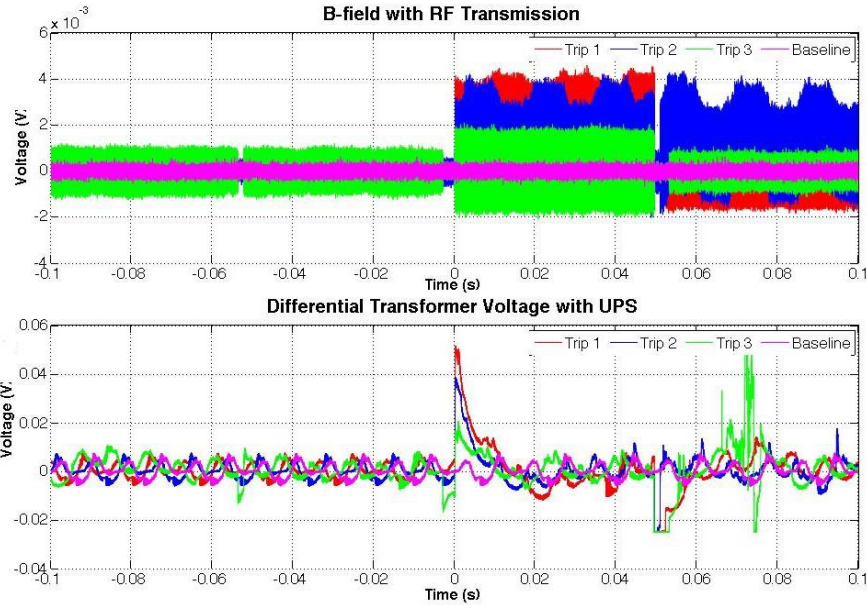

Figure 4-3 Tripping event of differential transformer while GFCI is powered from UPS.

Top: B-field created from RF transmissions of Smart Meter, Bottom: differential transformer voltage during the same time span as the RF transmissions. Each color of the RF transmissions corresponds with the differential voltage waveforms of the same color.

Despite the large number of transients recorded, the GFCI only tripped after the trigger event occurred. Since both the Smart Meter and the GFCI device were powered off of separate electrical circuits and tripping events were still recorded, these tests confirmed that there is radiative interference from the RF transmissions. Again, this does not mean it is the sole culprit and the only source of interference, only that it is a significant factor regarding GFCIs tripping in this particular setup with Smart Meters. The radiative coupling may be getting coupled directly into the GFCI's PCB/sense coils and/or it could be getting coupled into the power lines feeding the GFCI

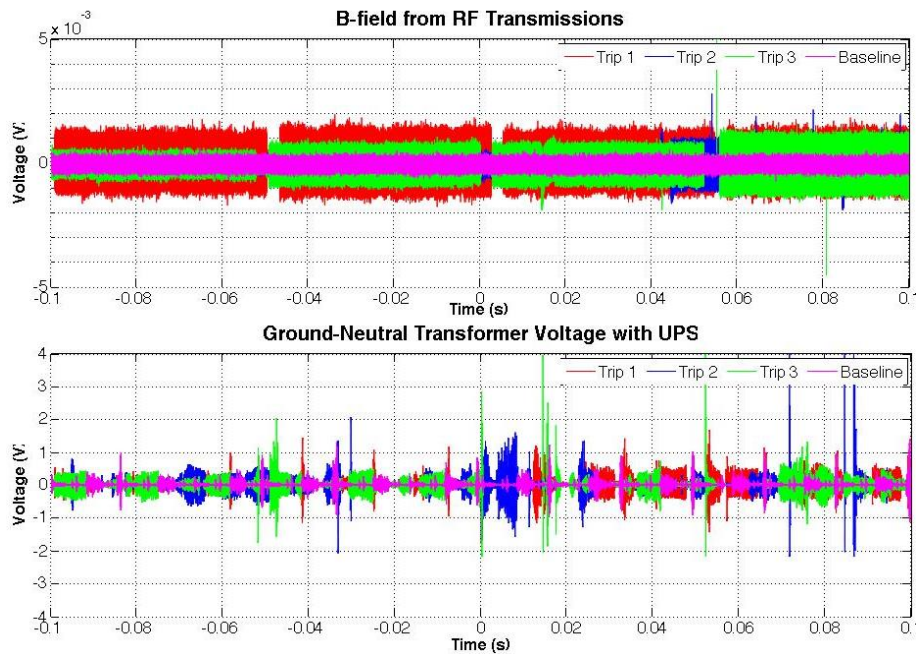

Figure 4-4 Tripping event of ground-neutral transformer while GFCI is powered from UPS. Top: B-field created from RF transmissions of Smart Meter, Bottom: ground-neutral transformer voltage during the same time span as the RF transmissions. Each color of the RF transmissions corresponds with the ground-neutral voltage waveforms of the same color.

Chapter 5

Additional Testing and Notes

During all of the research and experiments conducted, there were a few points of interest noted, as well as some minimal testing done. These are discussed below.

5.1 Brass vs. Copper

In one manufacturer's GFCI, the neutral conductor found inside was made of copper rather than the typical brass. The hot conductor was still made of brass, but this particular model with the copper neutral conductor never tripped. Only one of these types of devices was ever found in stores and after calling that particular GFCI's company they informed us that it was an older model and no longer available. With this in mind, a GFCI that used all brass conductors was taken apart and the conductors were covered with copper tape. This can be seen in Figure 5-1. By doing this, all tripping effectively stopped, suggesting that GFCIs with copper conductors may be a potential solution. The only hypothesis explaining why this would matter is that the difference in the skin depth between copper and brass within the frequency range of interest impacts the coupling of the RF into the device. Skin depth is a measure of how closely current may flow at the surface of a conductor. Copper's skin depth at 1GHz is 2.07 μm , and Brass is 4.21 μm , though based on the purity of these materials these numbers are subject to change. [19] At higher frequencies, this depth becomes much smaller and thus can act as an antenna. In fact, this is why some antennas are tubes rather than solid metal since they can pick up the signal just as well, but with less materials used allowing for cheaper and lighter products. Since the skin depth of copper is about half that of brass, so this could potentially be the difference between tripping and not tripping. However, it's not clear whether or not the conductors were acting as an antenna, or if the skin effect difference was simply acting as a filter. More research needs to be done before this claim can be

made, of course, but it was decided that this wasn't worth looking in to since no additional GFCIs with copper conductors could be located.

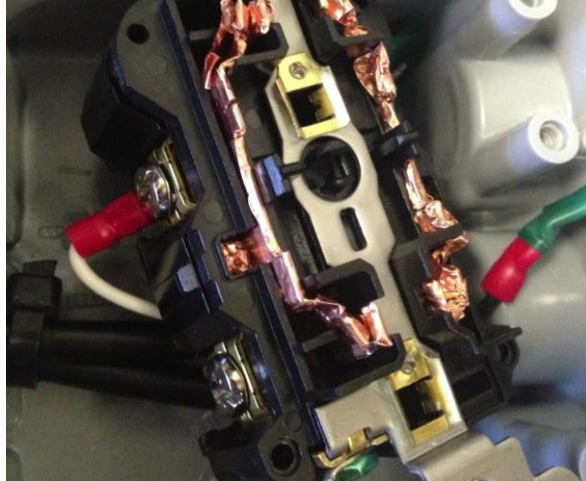

Figure 5-1 A GFCI with copper tape wrapped around the hot and neutral brass conductors. This successfully prevented any tripping from occurring.

5.2 Antenna Testing

It was noticed that when the power line being shared between the Smart Meter and the GFCI was moved during testing that this would sometime induce tripping. Literally moving the wire a few inches would immediately cause tripping to occur. After some testing, it was found that placing the wire in a looped fashion that it would begin to trip more often than before. At this time it was known that interference being experienced by the GFCI was a combination of both radiative and conductive types, but the possibility that the shared power line acted as an antenna had yet to be considered. It was assumed that the components affected by radiative interference must be the ones affected by magnetic fields (such as the differential transformers and the solenoid found in the GFCIs).

In this test, aluminum foil was used to completely cover the Smart Meter in order to mitigate the majority of RF signals emanating from the case. The GFCI was powered as normal, off of the Smart Meter. Then, the B-field probe was hooked up to the spectrum analyzer in order to measure the intensity of the frequencies transmitted by the Smart Meter. Once this was done, the probe was used to take a sample reading of the signal outside of the aluminum foil in order to ensure that the signal was being relatively suppressed, about half the intensity as normal. After this was concluded, the probe was then placed directly on the power line being shared between the GFCI outlet box and the Smart Meter. The intensity of the signal was significantly higher than previous signal recorded outside, roughly 10-20 dBm.



Figure 5-2 A screen capture from a video recording of evidence of GFCI tripping due to RF interference of a Smart Meter. Here, it can be seen that the wires being used to power the GFCI off of the Smart Meter are put in a circular fashion. It was found that this increased tripping events, and is possibly acting as an antenna.

These results suggest that the power line is indeed acting as an antenna and is picking up the RF signal from inside the Smart Meter where nothing is shielded. However, while measuring the field strength near the power line the GFCI would not always trip. This most likely means that the RF is inducing just enough current to trip the differential transformer, but not consistently. This is why when the power line is oriented in a “loop” it picks up the signal much better – just like the loop antennas used for RFID tags – and thus the GFCI trips more often.

Chapter 6

Conclusion

6.1 Proposed Solution

In order to develop a solution that is as simple and user-friendly as possible for construction sites, ferrite beads were proposed as the best fit. This was the initial 'go-to' solution purely from intuition, but with thoroughness in mind it was decided to first evaluate its impact through similar experimentation as that already discussed.

In these tests, two ferrite beads were used in an attempt to 'choke' the RF signal from being picked up by the power lines. Two power lines (each containing a hot, neutral and earth ground wire) are carried from the Smart Meter up to the metal enclosure where the GFCI outlets are located. Two different types of GFCIs from two different manufactures are housed on the stand. In the first set of tests performed, ferrite beads made of Fair-Rite 61 material (200-1000MHz, part 0461178281) were placed around the entire power line connecting the Smart Meter to the GFCIs. When this was done, the system was powered on and the GFCI tripped within one minute of activity. This implies that the placement was not at a sufficient choke point, and thus not able to effectively eliminate the RF interference. Next, instead of having the ferrite beads located close to the Smart Meter it was decided to put them closer to the GFCIs. Also, instead of having one ferrite bead around the entire power line, individual beads were placed around the hot, neutral, and earth ground terminals feeding each GFCI. This is seen in Figure 6-1.

The system was then powered on and left for a total of 108 hours in multiple configurations with no trips occurring. Due to this, it is believed that ferrite beads placed upon the hot and neutral lines near the GFCI devices are the best solution regarding effectiveness combined with user-friendly installation. In a final set of tests, ferrite was

also applied within the Smart Meter itself, as depicted in Figure 6-2, and again no trips were recorded. A summary of these results is listed in Table 6-1.



Figure 6-1 Ferrite beads placed on the hot, neutral, and earth ground lines of two brands of GFCIs. Note, the two ferrites on the hot line, though this proved to be unnecessary.

The far right device is a regular outlet and not a GFCI.

It is important to note that while the GFCIs did trip when no ferrite was applied to the adjustable test stand setup mentioned earlier, they did not trip nearly as much as in previous tests when the stand was not used. This is due to the metal containments around each device acting as an RF shield. With this in mind, it seems that the metal housing is nearly completely preventing the signal from coupling by radiation and that the tripping is from conduction. This also supports the theory that ferrite beads are working as intended to stop any tripping from occurring.

The metal does not act as a consistent shield, but it suggests that the majority of interference may be radiative rather than conductive. This also means that the shared power line is most likely picking up some amount of interference and creating more trips

than normal, thus why trips still occur whether or not the test stand is used. Due to this observation, it is suggested that all wires used in setting up these stands on construction sites be as short as possible so they do not pick up RF interference as easily.

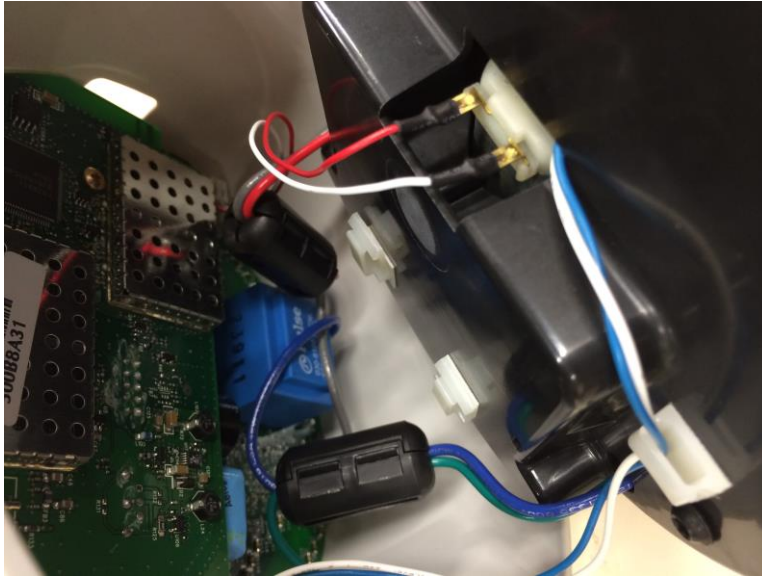

Figure 6-2 Ferrite applied from within the Smart Meter, one on the red and white wires, and one on the blue and green wires. These locations were provided by the contracting company and were claimed to be preventing any tripping from occurring.

Table 6-1 Ferrite bead testing in multiple arrangements. Each test was repeated three times and the time before a trip occurred was recorded.

Ferrite Test	Time On	Trip	Trip Time	Test Repeated
No Ferrite	5 min.	Yes	<1 minute	3 times
Single Ferrite around Power Line Out of the Smart Meter	5 min.	Yes	<1 minute	3 times
On Both GFCIs Only	12 hours	No	N/A	3 times
Inside Smart Meter Only	12 hours	No	N/A	3 times
On Both GFCIs & Smart Meter	12 hours	No	N/A	3 times

In order to confirm that the ferrite beads were indeed working as intended, an extra test was conducted. Ferrite beads were placed on the GFCI's hot, neutral, and earth ground lines, and voltage measurements were taken from the differential transformer. As mentioned earlier, when conducting tests on the construction stand without ferrite some tripping still occurred. Because of this, it's thought that the metal compartments of the construction stand are helping to block any interference, though some may still get through conductively. With this in mind, while testing the ferrite's ability to suppress interference on the differential transformer, one trip did occur. However, when looking at the measured voltage it was clear that much less noise was being picked up by the transformer when compared to the waveforms during the distance testing. This can be seen in Figure 6-3 below. Note that the peak voltage of this waveform is roughly 0.6875 V compared to the other tests which were around 0.701 V (Figures 4-1 through 4-4). This could mean that other interference was occurring regardless of transmissions.

Using this information, it can be inferred that the GFCI is experiencing interference due to radiative coupling into the wire, and then conductive coupling. This is why the ferrite beads are successfully suppressing the majority of interference through the power lines shared by the GFCI and the Smart Meter. In other words, combining the metal compartment's ability to block most of the radiative interference, and the ferrite's ability to relieve the GFCI of most of the conductive interference, tripping events appear to be mitigated. This also means that there isn't just purely one source of interference, but rather both radiative and conductive sources.

6.2 Discussion

A large amount of testing has been conducted in this study, but done with a limited supply of available instruments and knowledge when it comes to Smart Meters

and GFCI units. Because of this, some makeshift methods had to be created in order to fully test some hypothesis.

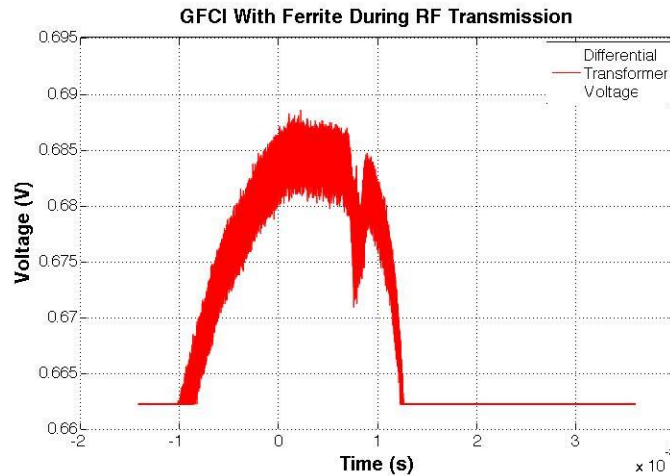

Figure 6-3 Voltage measurements of the differential transformer of a modified GFCI while ferrite beads are applied to its hot, neutral, and earth ground wires, and during RF transmission of the Smart Meter. It's clear that there is much less noise than during the distance testing with the modified GFCI previously (Figures 4-1 through 4-4). The extra spike is an anomaly that couldn't be identified (a new light bulb was used as the other one burnt out), but didn't hinder any performance of the load.

Not only that, but many observations have been made that are not able to be definitively tested without proper equipment, and thus assumptions are the only thing that can be in place of a true conclusion. While this is acceptable for this study as a solution has arisen, still more testing would need to be done in order to fully eliminate interference from occurring rather than placing a "Band-Aid" with ferrite beads. However, ferrite beads would still most likely be the correct solution as they are extremely easy to implement – especially for construction sites where all the hardware setups most likely already exist

and modification to those would be a hassle. With that in mind, some review of different possibilities and other tests that still need to be done will be covered in this section.

First of all, creating a heat map of electromagnetic field components is not something that should be done by simply measuring certain points and interpolating. This is an extremely crude way of mapping the RF field, but at the same time there is no cheap modern technology that will do this yet. The way this map was constructed was by measuring the field in terms of dBm with both E-field and B-field probes, but only measuring at different designated angles in relation to the Smart Meter, and only up to 15.5 inches. Once this was done, patterns were looked for by hand and it was found that the field was the strongest in the 0-degree to 90-degree range with respect to the front of the Smart Meter (and as can be seen in Figure 3-1 in Chapter 3). This data was then placed into Microsoft Excel and arranged in such a way that the bottom left corner represented the origin of the field within the Smart Meter, and there were numbers extruding in vertical, horizontal, and a diagonal 45-degree arrangement. In order to complete the field, the known numbers were used to interpolate other data points that were most likely to represent the actual field. This is how the three fields in Chapter 3 were constructed (Figures 3-2, 3-3, and 3-4). It was found that the 3-axis fields measured by EPRI had the same pattern as what we came up with, and it was deemed acceptable. Keep in mind, these maps were merely to look for patterns and not meant to be completely accurate. The entire purpose of the heat map was to identify if perhaps the GFCI was being placed in a “hot spot” being created by the Smart Meter, so a perfectly mapped field isn’t necessary. Keep in mind that the transmission power of the Smart Meter is not consistent at all. Different strength signals are constantly detected by our probes regardless of their distance from the Smart Meter. Often times some much stronger signals were picked up much farther away than anticipated, so multiple samples

would be taken and the average signal strength became what was actually used.

Because of this, no map of this transmitter's field will ever be exact and an approximation must be considered instead.

A crude but definitive test for whether or not radiative interference was one of the culprits for the GFCI tripping was using a UPS. No theory or math was done, but intuition said that if the two circuits powering the devices are completely separate and tripping still occurs, that some radiative interference must be occurring. Since rooms typically have their wall outlets all wired together, this technically means that if the Smart Meter is plugged into an outlet and then the GFCI is plugged into another outlet, both devices aren't actually on separate circuits. This is why a UPS was brought in, thus eliminating any uncertainty and allowing the GFCI to be powered entirely off of battery power. As soon as the GFCIs tripped with no physical path leading to the Smart Meter, this was the turning point for questioning whether the conductive or radiative interference was the dominant culprit. All previous tests were subject to both types of interference, but it wasn't clear whether only one or both was affecting it, or even if a combination of the two were necessary.

Capturing data clearly showing a trip event occurring at the same time as a transmission proved to be another challenge. Smart meter RF transmission power didn't appear have any pure correlation with whether or not the GFCI would trip or not. Often times measurements of the differential transformers would show voltage spikes without any trips, but on other occasions voltage spikes of similar magnitude would trip the GFCI. This somewhat implies that the interference causing trips isn't only affecting the differential transformers, but other components as well. However, the challenge this creates is using the oscilloscope to actually capture measured data on screen, but only when the GFCI would actually trip. Since voltage peaks of the differential transformer

were constantly different when the GFCI would trip, the trigger was placed on the B-field instead. While this was much easier to trigger off of, transmissions were happening constantly making it hard to capture the same transmission as when the GFCI would trip. This meant manually triggering the oscilloscope over and over in attempt to capture a good example of a trip. Also, when the Smart Meter stops attempting to connect to the network frequently after being powered on for so long the power of the transmissions become much lower as well. Every fifteen minutes the Smart Meter would need to be powered off for around 30 minutes in order to let the it reset itself. Keep in mind that no information regarding Smart Meter operation (other than the front button displaying different information when pressed) is publicly available in order to prevent the public from manipulating Smart Meter operation.

As an another example, no real antenna theory was used when determining whether or not the shared power line between the GFCI and the Smart Meter was actually acting as an antenna. However, being able to physically observe the difference in trips occurring by simply rearranging the wire without a doubt made it into an antenna. The only way of actually having any hard evidence of the wire acting as an antenna was the B-field and E-field measurements when the probes were placed on top of it. When this was done, the transmissions were clearly much stronger the closer the probes were to the wire, even when measurements were done very close to the Smart Meter. However, it was realized that this could have also meant that the wires were picking up conductive interference from the Smart Meter's PCB. This being realized, it made the theory of the wire acting as an antenna much stronger. If there was conductive interference, then the placement of the wire wouldn't matter. Since trips occurred more often when the wire was put into a loop shape, then regardless of conductive interference there was some sort of antenna affecting the GFCI's operation. Not to mention, often

times antennas are constructed in loops to increase the ability to pick up signals. Like it was mentioned earlier, none of this was done in a professional fashion, but this is due to lack of knowledge in this area and not having necessary equipment. Regardless, there is undisputable evidence of the shared power line acting as an antenna. Also, this effect never occurred when the GFCI and Smart Meter were installed into the construction stand. This is thought to be due to the wire from the Smart Meter being cut short and going straight to the GFCI above it, as well as the wire being encased in a conduit as can be seen at the bottom of Figure 6-1.

Since it was now known that radiative interference alone could trip a GFCI, it still didn't answer the question as to whether it was tripping the GFCI while on the construction stand. Metal compartments surrounded both the GFCI and the Smart Meter, as can be seen below in Figure 6-4, and intuition says that this should block a large amount of any RF transmission. There wasn't a set test for this theory, but when measuring the B-field both outside and inside the box there was a large decrease in signal strength. However, when measuring the B-field inside the box sometimes it would be just as it was outside the box. It was found that this was due to the probes being close to the hot, neutral, and (or) ground wires of the GFCIs. When the probe was not as close to the wires the signal strength would decrease as expected. In fact, even when the probe was simply placed behind the metal compartment the signal would be much lower than when in front. Since tripping still occurred when the two devices were configured in the construction stand, and it was seen that purely radiative interference can cause a GFCI to trip, it appeared that conductive interference was the main culprit. Tripping on the stand occurred much less often than without, which is of course due to the metal compartments acting as a shield. This further supported ferrite beads as the best

solution, and also suggested that while both radiative and conductive interference could trip the GFCI independently, the radiative interference was much more effective at it.

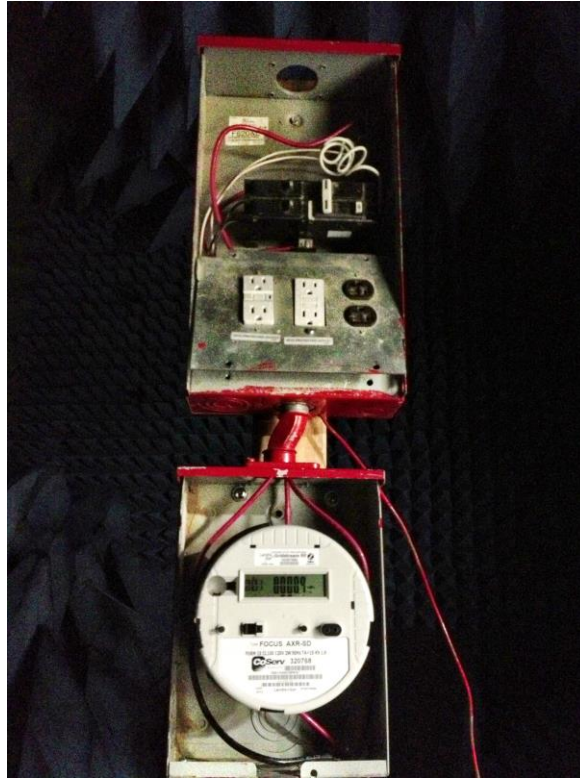

Figure 6-4 The construction stand used for testing the Smart Meter and GFCIs. Note that the fronts of the metal compartments are missing, but during tests were placed back on in attempt to replicate as closely as possible the scenario found on construction sites.

As an aside to what was mentioned earlier regarding much less tripping, previously the wires used to power the GFCIs off of the Smart Meter on the construction stand were around one meter long. This was so the Smart Meter could be adjustable in relation to the GFCI receptacle in attempt to prevent tripping simply by adding more distance between the two devices. Once it was discovered that the wires were acting as

an antenna for the RF transmissions, as well as realizing that the distance between the GFCI and Smart Meter didn't matter in this configuration, the wires were cut down. This was also done to configure the stand as closely as possible to what was found in actual construction sites. After this was done the amount of tripping drastically decreased. If construction sites are having trouble with tripping and the wires used to power the GFCI were not cut down and simply shoved inside the metal box then this could potentially be the problem.

6.3 Future Work

Although a solution was found and presented to the sponsor, there could still be further analysis of many of the tests already done. As mentioned, many of the tests conducted were crude due to lack of appropriate test equipment and lack of cooperation with GFCI manufacturers.

Any device that has an inductive load, specifically an inductive load that changes, can trip a GFCI. This is the same reason that refrigerators are not supposed to be plugged into GFCIs, as the coils used may move the power out of phase. An example of this can be seen in Figure 6-5. While most handheld tools are generally okay to use, if something like a table saw were to be plugged in to a GFCI more than likely it would cause a trip. It was never specified what was actually being plugged into the GFCIs on the construction stand, but it was assumed that a construction site would most likely know that it's bad practice to use inductive loads with their GFCIs.

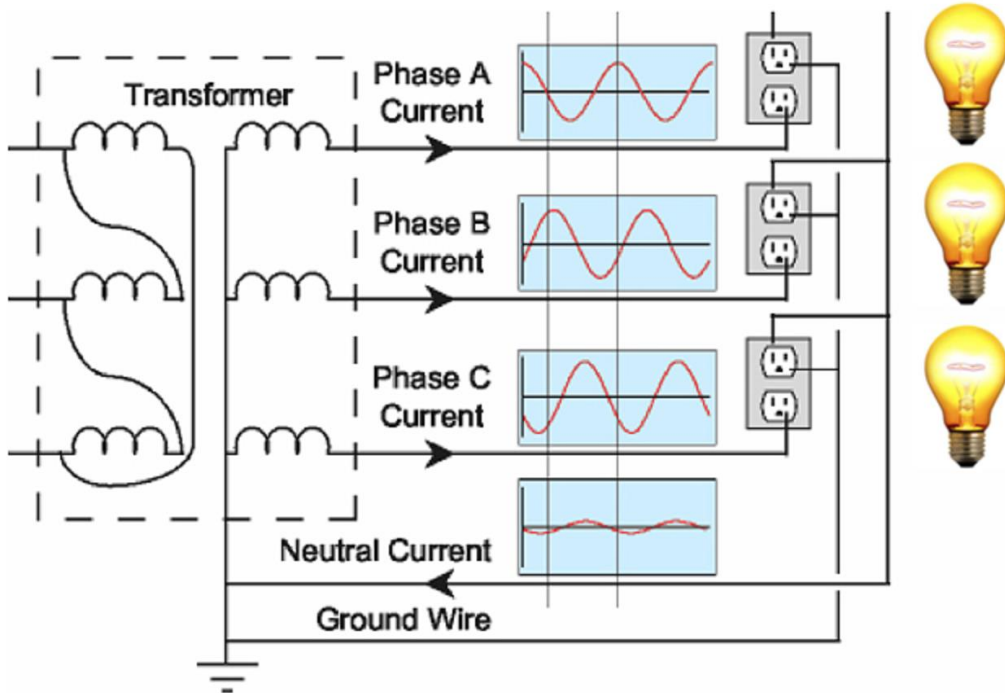

Figure 6-5 An example of how power phase, and thus current phase, of inductive loads can trick GFCIs into seeing a differential of current moving through them and causing trips. This could be a potential cause of trips for construction sites if they use certain power tools.

9.3 Conclusion

This study presented a look into a specific problem that construction sites experience when they implement Smart Meters into their work areas. Construction crews must have a Smart Meter in order to keep track of power used, but regulation states that any tools used outside and are potentially exposed to the elements must use a ground fault circuit interrupter – or GFCI. However, a problem started to arise when Smart Meters and GFCIs were combined: the GFCI would seemingly have random trips occur,

interrupting the construction workers and stop work flow. This became such a problem that they complained to the utility company, and thus sponsored this project.

A high level of intuition and well-constructed tests were used in order to obtain conclusive evidence of the different sources of interference. Maps of the electric and magnetic fields created by the Smart Meter RF transmissions were made in an attempt to identify a potential “hot spot” that may be causing trips. This hot spot was located at the 45-degree angle relative to the front face of the Smart Meter. It was concluded that both radiative and conductive interference was occurring, both of which could completely independently cause the GFCI to trip. This was found by completely separating the two devices from any shared connections and finding that trips could still occur. Not only could conductive interference occur between the two devices, but the wire used to power the GFCI off of the Smart Meter was acting as an antenna. In fact, the position of the shared power line could amplify the results and cause more trips than normal. Because of this, it’s important to keep the shared line as short as possible. Once the culprit was identified as both conductive and radiative, tests were conducted with both devices installed as realistically as possible on to a construction stand. The stand was located in an anechoic chamber to eliminate any possible outside interference from occurring. It was found that once the shared power line was made to be shorter, the frequency of trips became much lower. This suggested, as one can expect, that the metal GFCI and Smart Meter boxes on the construction stand was blocking most radiative interference. However, conductive interference was still a possibility, and thus the solution of ferrite was conceived. Not only that, but a realistic and user-friendly solution was needed by the construction sites. Creating some type of filter is completely possible, but asking construction sites to install a filter means that they must open up the GFCIs or Smart Meter itself and install them from within. This is not the most desirable solution and is

rather intrusive, and so applying ferrite beads that can simply snap on to wires has come to be the best solution.

References

- [1] U.S. Department of Energy, "Smart Grid," 7 July 2013. [Online]. Available: <http://energy.gov/oe/technology-development/smart-grid>. [Accessed 7 July 2013].
- [2] R. Lasseter, J. Eto, B. Schenkman and e. al, "CERTS Microgrid Laboratory Test Bed," Power Delivery, IEEE Transactions on , vol. 26, no. 1, pp. 325-332, 2011.
- [3] S. S. S. R. Depuru, L. Wang, and V. Devabhaktuni, "Smart meters for power grid: challenges, issues, advantages and status," Renewable and Sustainable Energy Reviews, vol. 15, no. 6, pp. 2736–2742, 2011
- [4] 'Smart Meter deployments continue to rise,' (2012, Nov. 1) U.S. Energy Information Administration. [Online] Available: <http://www.eia.gov/todayinenergy/detail.cfm?id=8590>
- [5] Z. Zhang, W-J. Lee, D.A. Wetz, B. Shrestha, J. Shi, A. Jackson, H. Honang and J. Fielder, 'Evaluation of the Switching Surges Generated during the Installation of Legacy and 'Smart' Electric Metering Equipment,' Proceedings of the 48th Industrial & Commercial Power Systems Technical Conference, Louisville, Kentucky, May 20 – 24, 2012.
- [6] 'Ground-Fault Circuit Interrupters (GFCIs),' Energy Education Counsel, [Online]. Available: <http://www.safeelectricity.org/information-center/library-of-articles/55-home-safety/317-ground-fault-circuit-interrupters-gfcis>
- [7] UL 943 Standard for Safety, Ground Fault Circuit Interrupter (Underwriters Laboratories, Northbrook, IL, 2003) [Online]. Available: <http://bbs.dianyuan.com/bbs/u/33/1127525378.pdf>
- [8] R. A. Tell, G. G. Sias, A. Vazquez, J. Sahl, J. P. Turman, R. I. Kavet and G. Mezei, Radiofrequency fields associated with the Itron smart meter. *Radiat. Prot. Dosimet.* 151:17-29, 2012.

- [9] B. Christe, E. Cooney, G. Maggioli, D. Doty, R. Frye, J. Short, Testing potential interference with RFID usage in the patient care environment. *Biomed. Instrum. Technol.* 42 (2008), pp. 479–484
- [10] W. D. Ford and R. G. McCormack, “Investigation of ground fault circuit interrupter,” *Construction Eng. Res. Laboratory, Champaign, IL, Tech. Rep. E92*, Sep. 1976.
- [11] National Electric Manufacturers Association. (2012, Oct. 22) Understanding GFCIs. [Online]. Available: <http://www.nema.org/Products/Documents/NEMA-GFCI-2012-Field-Representative-Presentation.pdf>
- [12] J. De Armond. (2000). The “Hows” and “Whys” of Ground Fault Circuit Interrupters. [Online] Available: http://www.rvpowerprotection.com/Links_files/GFI.pdf
- [13] A. H. Kim, C. J. Nwamu. (2011, Oct. 18). Pacific Gas and Electric Company’s Response to Administrative Law Judge’s October 18, 2011 Ruling Directing it to File Clarifying Radio Frequency Information. [Online]. Available: <https://smartmeterharm.files.wordpress.com/2014/07/pge-rf-data-11-1-11.pdf>
- [14] R. Kavet, G. Mezei. (2011, Feb.). EPRI Comment: Sage report on radio-frequency (RF) exposures from smart meters. *Electric Power Research Institute, Palo Alto, Ca, USA 2010*. [Online]. Available: http://www.socalgas.com/documents/ami/epri_sagereport.pdf
- [15] A. G. Tarditi, B. Seal. (2014, Mar.). “Characterization of Radio Emissions from Advanced Metering Infrastructure Revenue Meters (*Smart Meters*) in CPS Energy Residential Installations. *Electric Power Research Institute, Palo Alto, Ca, USA 2010*. [Online]. Available: http://www.cpsenergy.com/files/Smart_Grid/EPRI_Report_RF_Emissions.pdf

- [16] Kimball, Jonathan, and Jordan Henry. "Compatibility between GFCI breakers and household adjustable speed drives." *Energy Conversion Congress and Exposition, 2009. ECCE 2009. IEEE*. IEEE, 2009. [Online]. Available: <http://ieeexplore.ieee.org/stamp/stamp.jsp?tp=&arnumber=5316372>
- [17] Beehive Electronics. 100 Series EMC Probes. [Online]. Available: <http://www.beehive-electronics.com/datasheets/100SeriesDatasheetCurrent.pdf>
- [18] Conductor Bulk Resistivity & Skin Depths. [Online]. Available: <http://www.rfcafe.com/references/electrical/cond-high-freq.htm>
- [19] G. Holt. (2012) Electrical Hazard Protection for the Entertainment Industry. [Online]. Available: http://www.screenlightandgrip.com/html/481_GFCI_Workshop.html

Biographical Information

Simon T. Donahue was born in Rockville, Maryland in 1989. He received the B.S. degree in electrical engineering from the University of Texas at Arlington where he is receiving his masters in December 2014. His interests include pulsed power and energy storage, both of which are his main research topics. After graduating he hopes to begin his career in the network deployment field regarding renewable energy storage.