

INTERFERENCE MITIGATION IN 4G LTE-A
HETEROGENOUS NETWORKS

by

ROHAN NAG KUMMITHE

Presented to the Faculty of the Graduate School of
The University of Texas at Arlington in Partial Fulfillment
of the Requirements
for the Degree of

MASTER OF SCIENCE IN ELECTRICAL ENGINEERING

THE UNIVERSITY OF TEXAS AT ARLINGTON

December 2012

Copyright © by Rohan N Kummithe 2012

All Rights Reserved



Acknowledgements

It is with immense pleasure that I acknowledge the guidance of my professor Dr. Qilian Liang for his continuous support during my thesis. His expertise, patience and understanding have added considerable value to my graduate experience and have made the research a very memorable and a knowledgeable experience.

I would also like to extend my appreciation to Dr. Shu-Shaw Wang who introduced me to LTE, which gave me an invaluable insight into the present wireless communications industry.

This is a perfect opportunity to thank my parents who have helped me overcome many tough challenges and for showing immense trust in my abilities, without whom my Master's degree and the research would have been a distant possibility.

Last but never the less, I would like to thank all my friends who have supported me during the course of my Master's degree and thesis. Special thanks to Priyadarshini who has been a constant source of strength and support.

December 11, 2012

Abstract

INTERFERENCE MITIGATION IN 4G LTE-A
HETEROGENOUS NETWORKS

Rohan Nag Kummithe, M.S.

The University of Texas at Arlington, 2012

Supervising Professor: Qilian Liang

Long Term Evolution (LTE) complements 3G networks with high data rates, low latency and a flat, IP-based architecture. It also allows operators to use a new and a much wider spectrum when compared to the previous standards. To further enhance this and to achieve the constraints set by the International Mobile Telecommunication-Union (IMT-U), 3GPP has been working on various aspects of the LTE-Advance standard which has been officially termed as 4G network.

Apart from the enhancements in the radio link, the next performance leap in wireless networks will come from an evolved network topology. The concept is to improve spectral efficiency per unit area. Using different combinations of femto cells, relays and pico cells, heterogeneous networks can provide the optimal experience to the user.

The drawback to all this is that there will be severe interference between various components in the heterogeneous networks. Furthermore, as the femtocells are user deployed, the interference management schemes become even more important. These interference mitigation techniques also need to counter the interference between network components macrocell and femtocell in a heterogenous network. To counter the above mentioned problems, to increase the throughput and to meet the data rates set by the

standard, technologies such as Carrier Aggregation (CA) and Coordinated Multipoint transmission/reception (CoMP) have been defined.

In this thesis an implementation of the technologies CA and CoMP have been proposed to target the performance of 4G networks. This has been implemented in a macrocell-femtocell network for the downlink transmission. This coordination improves the quality of the received signal and also increases the capacity of each user thus increasing the capacity of the entire system.

Table of Contents

Acknowledgements	iii
Abstract	iv
List of Acronyms.....	ix
List of Illustrations	xii
List of Tables.....	xiv
Chapter 1 Long Term Evolution	1
1.1 Introduction	1
1.2 Requirements & Targets for the LTE.....	2
1.3 System Performance Requirements.....	2
1.4 LTE System Architecture	3
1.5 Technologies Used	6
1.5.1 Antenna Technology - MIMO	6
1.5.2 Air Interface - OFDM	9
Chapter 2 Long Term Evolution - Advanced.....	11
2.1 Introduction	11
2.2 Femtocells	12
2.3 Carrier Aggregation	13
2.4 Co-Ordinated Multipoint Transmission/Reception.....	15
2.4.1 Introduction.....	15
2.4.2 The CoMP Architecture	17
2.4.2.1 Centralized Architecture.....	18
2.4.2.2 Distributed Architecture.....	18
2.4.3 CoMP Schemes.....	19
2.4.3.1 Coordinated Scheduling/Beamforming.....	19

2.4.3.2 Joint processing	20
Chapter 3 Femto Cells	23
3.1 Introduction	23
3.2 FemtoCell Architecture	24
3.3 Deployment of Femtocells & their Challenges	25
3.4 Industry Activity.....	27
3.5 Radio Issues for Femtocells	27
Chapter 4 Interference Scenarios	29
4.1 Introduction	29
4.1.1 Co-Layer Interference	29
4.1.2 Cross-Layer Interference.....	31
Chapter 5 System Simulator	33
5.1 System Architecture	33
5.1.1 User Input Module:	34
5.1.2 Path loss Estimation Module:	34
5.1.3 SINR Estimation Module:	35
5.1.4 Capacity Calculation Module:	35
5.1.5 User Output Module:	35
5.2 Analysis and Parameters.....	36
5.2.1 Path Loss Model.....	36
5.2.2 SINR Estimation	37
5.2.3 Throughput Calculation	37
5.2.4 Using the Simulator	38
5.3 Frequency Reuse Schemes	40
5.3.1 Proposed Frequency Reuse Scheme	41

5.4 Implemented Algorithm.....	41
5.5 Parameters Considered.....	43
Chapter 6 Simulation & Results	44
6.1 Schemes Used	44
6.1.1 Conventional Scheme	44
6.1.2 Proposed Scheme.....	44
6.1.2.1 Carrier Aggregation.....	44
6.1.2.2 CA along with Co-Ordinated Multipoint Tx/Rx	45
6.2 Topology Used.....	46
6.3 Results.....	48
6.3.1 CDF of Throughput (bps)	48
6.3.2 Throughput (bps) vs. Distance (m).....	51
6.3.3 SNR (dB) vs. Throughput (bps).....	54
6.3.4 Bandwidth efficiency (η)	56
Chapter 7 Conclusion and Futurework	59
7.1 Conclusion	59
7.2 Futurework.....	60
References.....	61
Biographical Information	63

List of Acronyms

3G	Third Generation
3GPP	Third Generation Partnership project
AMPS	Advanced Mobile Phone Service
ARQ	Automatic Repeat Request
BS	Base Station
bps	Bits per second
CAPEX	Capital Expense
CA	Carrier Aggregation
CDF	Cumulative Distribution Function
CCU	Cell Center User
CEU	Cell Edge User
CCI	Co-Channel Interference
CDMA	Code Division Multiple Access
CoMP	Coordinated MultiPoint transmission/reception
CP	Control Plane
CS/CB	Coordinated Scheduling / Coordinated Beamforming
CSG	Closed Subscriber Group
DFT	Discrete Fourier Transform
DL	DownLink
eICIC	Enhanced InterCell Interference Coordination
EPC	Evolved Packet Core
E-UTRAN	Evolved Universal Terrestrial Radio Access Network
FAP	Femtocell Access Point
GGSN	Gateway GPRS Support Node

GPRS	General Packet Radio Service
GSM	Global System for Mobile telephony
HeNB	Home enhanced Node – Basestation
HSPA	High Speed Packet Access
HSS	Home Subscriber Service
ICI	Inter-Cell Interference
IP	Internet Protocol
ITU	International Telecommunication Union
LTE	Long Term Evolution
LTE - A	LTE – Advanced
MIMO	Multiple Input Multiple Output
MME	Mobile Management Entity
MSC	Mobile Switching Center
OFDM	Orthogonal Frequency Division Multiplexing
PAPR	Peak to Average power Ratio
PCRF	Policy and Charging Rules Function
PDN	Public Data Network
PDSCH	Physical Downlink Shared Channel
P-GW	PDN Gateway
PL	Path Loss
PUSCH	Physical Uplink Shared Channel
QoS	Quality of Service
RAN	Radio Access Network
RNC	Radio Network Controller
SAE	System Architecture Evolution

SC-FDMA	Single Carrier – Frequency Division Multiple Access
S-GW	Serving Gateway
SINR	Signal to Interference and Noise Ratio
UE	User Equipment
UL	UpLink
UMTS	Universal Mobile Telecommunication System

List of Illustrations

Fig 1-1 LTE Radio Access Network Architecture.....	4
Fig 1-2 LTE/SAE Architecture.....	5
Fig 1-3 Multiple Antenna Techniques	7
Fig 2-1 Typical Femtocell.....	12
Fig 2-2 Carrier Aggregation	15
Fig 2-3 Illustration of CoMP	17
Fig 2-4 Co-Ordinated Scheduling/BeamForming.....	19
Fig 2-5 System model of two interfered users	20
Fig 2-6 Joint processing Techniques: Joint Transmission & Dynamic Cell Selection	21
Fig 3-1 Comparison of cell sized for different cells	23
Fig 3-2 Simplified Diagram of LTE Femtocell Network	25
Fig 5-1 System Architecture.....	33
Fig 5-2 Analytical results of a sample macro user & a femto user	35
Fig 5-3 Initial Simulator Screen.....	38
Fig 5-4 Sample illustration after the deployment is completed	40
Fig 6-1 Topology with 30 Femtocells	47
Fig 6-2 Topology with 50 Femtocells.....	47
Fig 6-3 CDF of Throughput (BW – 20MHz, Femtocells - 30).....	48
Fig 6-4 CDF of Throughput (BW – 20MHz, Femtocells - 50).....	49
Fig 6-5 CDF of Throughput (BW – 100MHz, Femtocells - 30).....	49
Fig 6-6 CDF of Throughput (BW – 100MHz, Femtocells - 50).....	50
Fig 6-7 Throughput vs. Distance (BW – 20MHz, Femtocells - 30)	51
Fig 6-8 Throughput vs. Distance (BW – 20MHz, Femtocells - 50)	52
Fig 6-9 Throughput vs. Distance (BW – 100MHz, Femtocells - 30	52

Fig 6-10 Throughput vs. Distance (BW – 100MHz, Femtocells - 50)	53
Fig 6-11 SNR vs. Throughput (BW – 20MHz, Femtocells - 30).....	54
Fig 6-12 SNR vs. Throughput (BW – 20MHz, Femtocells - 50).....	54
Fig 6-13 SNR vs. Throughput (BW – 100MHz, Femtocells - 30).....	55
Fig 6-14 SNR vs. Throughput (BW – 100MHz, Femtocells - 50).....	55
Fig 6-15 Bandwidth Efficiency (BW – 20MHz, Femtocells - 30)	56
Fig 6-16 Bandwidth Efficiency (BW – 20MHz, Femtocells – 50)	57
Fig 6-17 Bandwidth Efficiency (BW – 100MHz, Femtocells - 30)	57
Fig 6-18 Bandwidth Efficiency (BW – 100MHz, Femtocells - 50)	58

List of Tables

Table 1-1 Summary of Key Performance Requirement targets for LTE	3
Table 5-1 System Level Simulation Parameters.....	43

Chapter 1

Long Term Evolution

1.1 Introduction

High speeds, lightning connectivity & uninterrupted connection; these are the requirements for every single user when asked about what they expect from a good data connection. Adding to that, with the more than exponential growth of the Internet, network suppliers have been asked to come up with something which meets all the above requirements. Since the advent of the 'Third Generation' (3G) cellular technology a decade ago, users have been promised a full mobile internet experience, which as of yet has not been completely fulfilled. Long Term Evolution (LTE) is a cellular standard which goes a long way in fulfilling the promise. The Long Term Evolution (LTE) of UMTS is just one of the latest steps in the advancing series of mobile telecommunications systems. It is marketed as 4G-LTE which is a standard for high-speed data and reduced latencies for the mobile phone users. LTE does not satisfy the standard set by the International Telecommunication Union-Radio Communication Sector (ITU-T), but, due to several other reasons, it has been declared as '4G' (Fourth Generation) by the ITU-T.

The 3rd Generation Partnership Project (3GPP) is currently the dominant standards development group for mobile radio systems. Within 3GPP, three multiple access techniques are evident: GSM/GPRS/EDGE which is marked as a 'Second Generation' evolution track. This has given way to the 'Third Generation' mainly known as the UMTS family which paved the way for Code Division Multiple Access (CDMA) technology and became known as Wideband CDMA or simply WCDMA. Finally, LTE has adopted Orthogonal Frequency-Division Multiplexing (OFDM), which is the access technology dominating the latest evolution of all the mobile standards.

The goal of LTE is to increase data rates, reduce the latencies and to increase the capacity of wireless data networks using various wireless technologies which were developed in

the recent past. It also intends to redesign and simplify the network architecture to an IP based system. A large amount of work is aimed at simplifying the architecture from the existing UMTS circuit + packet switching combined network, to an all IP flat based architecture. The expected downlink speeds are up to 100Mbps with latencies of less than 10ms. The evolution to an all IP based architecture promises significant cost saving and network efficiencies, while end to end usage of IP enables a multiplicity of services such as voice, video, data and gaming to be flexibly deployed under a single network architecture.

1.2 Requirements & Targets for the LTE

Discussion of the key requirements for the new LTE system led to the creation of a formal 'Study Item' in 3GPP with the specific aim of 'evolving' the 3GPP radio access technology to ensure competitiveness over a 10-year time frame. These requirements can be summarized as:

- Reduced delays, in terms of both connection establishment & transmission latency
- Increased user data rates
- Increased cell-edge bit-rate, for uniformity of service protection;
- Reduced cost per bit, implying improved spectral efficiency;
- Greater flexibility of spectrum usage, in both new and pre-existing bands
- Simplified network architecture
- Seamless mobility, including between different radio-access technologies
- Reasonable power consumption for the mobile terminal

To address these objectives, the LTE system design covers both the radio interface and the radio network architecture.

1.3 System Performance Requirements

Improved system performance compared to existing systems is one of the main requirements from network operators, to ensure the competitiveness of LTE. The table below summarizes the main performance requirements to which the first release of LTE was designed.

Table 1-1 Summary of Key Performance Requirement targets for LTE

DOWNLINK		Absolute requirement	Comparison to release 6	Comment
	Peak transmission rate	> 100Mbps	7x14.4 Mbps	LTE in 20 Mhz FDD, 2x2 spatial multiplexing.
	Peak spectral efficiency	>5bps/Hz	3bps/Hz	
	Average cell spectral efficiency	>1.6 - 2.1 bps/Hz/cell	3 – 4x0.53 bps/Hz/cell	LTE: 2x2, Interference Rejection Combining (IRC) receiver
	Cell edge spectral efficiency	>0.04 – 0.06 bps/Hz/user	2-3x0.02 bps/Hz	As above, 10 users assumed per cell
	Broadcast spectral efficiency	> 1 bps/Hz	N/A	Dedicated carrier for broadcast mode
UPLINK	Peak transmission rate	>50Mbps	5x11 Mbps	LTE in 20 Mhz FDD, single antenna transmission.
	Peak spectral efficiency	>2.5bps/Hz	2bps/Hz	
	Average cell spectral efficiency	>0.66 - 1.0 bps/Hz/cell	2 – 3x0.33 bps/Hz/cell	LTE: Single antenna transmission, IRC receiver
	Cell edge spectral efficiency	>0.02 – 0.03 bps/Hz/user	2-3x0.01 bps/Hz	As above, 10 users assumed per cell
SYSTEM	User plane latency (two way radio delay)	<10 ms	One fifth	
	Connection set-up latency	<100 ms		Idle state -> Active state
	Operating bandwidth	1.4 – 20 Mhz	5 Mhz	(initial requirement started at 1.25 Mhz)
	VoIP capacity	NGMN preferred target: > 60 sessions/Mhz/cell		

1.4 LTE System Architecture

LTE encompasses the evolution of the radio access through the Evolved-UTRAN (E-UTRAN), it is accompanied by an evolution of the non-radio aspects under the name ‘System

Architecture Evolution' (SAE) which includes the Evolved Packet Core (EPC) network. Together LTE & SAE comprise the Evolved Packet System (EPS)

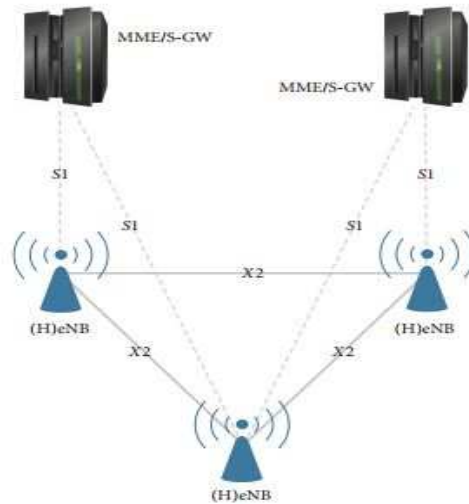

Fig 1-1 LTE Radio Access Network Architecture

EPS uses the concept of EPS bearers to route IP traffic from a gateway in the PDN to the UE. A bearer is an IP packet flow with a defined Quality of Service (QoS) between the gateway and the UE. The E-UTRAN with EPC together set up and release bearers as required by applications. The eNodeB is responsible for Radio resource Management (RRM) – assignment, reassignment and release of radio resources. It is used in the signaling of Access stratum signaling protocols, along with scheduling and transmission of paging messages received from the MME and broadcast information received from the MME. Other functions such as measurement gathering for scheduling, mobility decisions and routing the user plane data to S – GW are also taken care by the eNodeB.

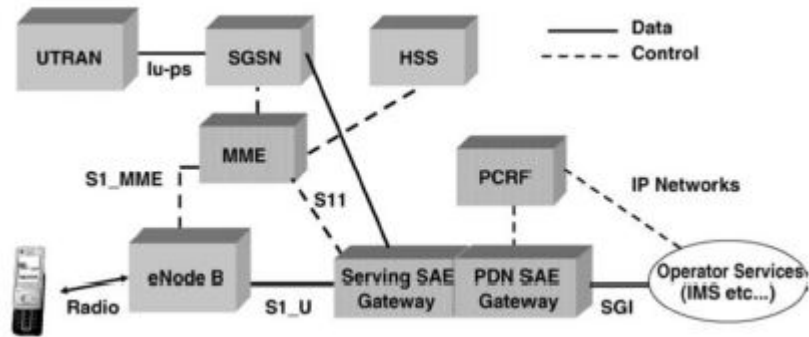

Fig 1-2 LTE/SAE Architecture

The User Equipment (UE) is mainly responsible for 3 functions. To mark its entry into the signal network and several other changes, to report its location while it is in the idle mode and requesting uplink grants to transmit data while in active mode. Apart from these functions several other measurements such as Reference Symbol Received Power (RSRP), Reference Symbol Received Quality (RSRQ), Received Signal Strength Indicator (RSSI), and Signal to Noise Ratio (SNR) are also carried out by the UE.

Mobile Management Entity (MME) helps authenticate UEs into the system, tracks active and idle UEs and pages UEs when triggered by the arrival of the new data. When a UE attaches to an eNB, the eNB selects an MME. MME in turn selects the Serving Gateway (S-GW) and the Packet Data Network Gateway (P-GW) that will handle the user's bearer packets. MME also takes care of the Non-Access stratum signaling and authentication (in conjunction with the Home Subscriber Server - HSS).

Serving Gateway (S-GW) routes and forwards user data packet, terminates downlink data for idle UEs and is also the local mobility anchor for inter-eNodeB handover. The mobility anchor function applies to both UE in the E-UTRAN and other 2G/3G technologies. The S-GW also maintains a buffer for each idle UE and holds the packets until the UE is paged and an RF channel is re-established. For each UE associates with the EPC, at a given point of time there is a single UE. Other functions of the S-GW include IP backhaul admission and congestion control, point of policy enforcement and IP backhaul Quality of Service (QoS).

Packet Gateway (P-GW) is responsible for the UE Internet Protocol (IP) address assignment and provides connectivity to the external packet data networks. The P-GW provides charging (billing) support, packet filtering/screening, policy enforcement and lawful intercept. If a UE is accessing multiple packet data networks, it may have connectivity to more than 1 P-GW.

Home Subscriber Server (HSS) is the master database that contains the UE profiles and authentication data used by the MME for authenticating and authorizing UEs. It also stores the location information of the UE which is used for user mobility and inter-technology handovers. The HSS communicates with the MME using Diameter protocol.

Policy and Charging Rules Function (PCRF) creates rules for setting policy and charging rules for the UE. It provides network control for service data flow detection, gating, QoS authorization and flow based charging. It applies security procedures, as required by the operator, before accepting service information. Decides how a certain service data flow will be treated in the P-GW and ensures that the P-GW user plane traffic mapping and treatment matches the user's subscription profile.

Serving GPRS (General Packet Radio System) Support Node (SGSN) is responsible for the delivery of data packets to and from UEs within its geographical service area. The SGSN provides the interfaces between the MME and S-GW in the Evolved Packet Core (EPC).

1.5 Technologies Used

1.5.1 Antenna Technology - MIMO

The value of multiple antenna systems as a means to improve communications was recognized in the very early ages of wireless communications. However, most of the scientific progress has happened only in the last two decades with MIMO being a key milestone.

While traditional wireless communications (Single-Input Single-Output (SISO)) exploit the time or frequency domain pre-processing and decoding of the transmitted and received data respectively, the use of additional antenna elements at either the eNodeB or UE (User Equipment) side opens up an extra spatial dimension to signal decoding and detection. Space-

time processing methods exploit this dimension with the aim of improving the link's performance in terms of one or more possible metrics, such as the error rate, communication data rate, coverage area and spectral efficiency (bps/Hz/cell).

Depending on the availability of multiple antennae at the transmitter and/or receiver, such techniques are classified as:

- SIMO: Single-Input Multiple-Output
- MISO: Multiple-Input Single-Output
- MIMO: Multiple-Input Multiple-Output

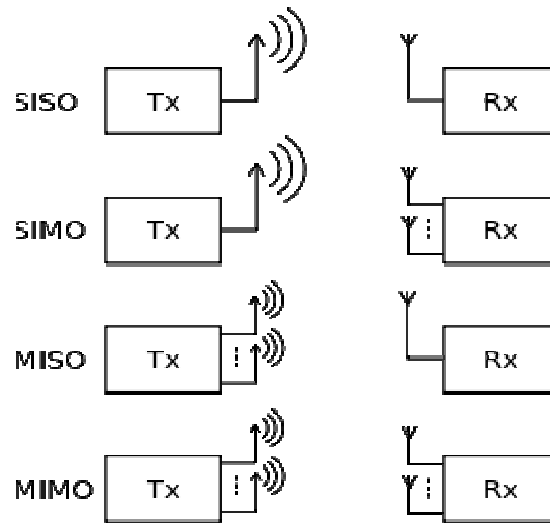

Fig 1-3 Multiple Antenna Techniques

So when we have multiple eNodeBs communicating with one antenna UE, it is referred as MISO or SIMO in the vice versa case. When a high end multi-antenna terminal communicates along with a multi antenna UE, it is referred as MIMO (Multiple-Input Multiple-Output), thus including SIMO and MISO as special cases. While a point-to-point multiple-antenna link between a base station and one UE is referred to as Single-User MIMO (SU-MIMO), Multi-User MIMO (MU-MIMO) features several UEs communicating simultaneously with a common base station using the same frequency and time domain resources.

Despite their variety and sometimes perceived complexity, single-user and multi-user MIMO techniques tend to revolve around just a few fundamental principles, which aim at

leveraging some key properties of multi-antenna radio propagation channels. The three advantages associated with such channels are Diversity gain, Array gain and Spatial multiplexing gain.

Diversity gain corresponds to the mitigation of the effect of multipath fading by means of transmitting or receiving over multiple antennae at which the fading is sufficiently de-correlated. It is typically expressed in terms of an order, referring either to the number of effective independent diversity branches or to the slope of the bit error rate curve as a function of the Signal-to-Noise Ratio (SNR). While diversity gain is fundamentally related to the improvement of the statistics of instantaneous SNR in a fading channel, array gain and multiplexing gain are of a different nature. Array gain corresponds to a spatial version of a well-known matched-filter gain in time-domain receivers, while multiplexing gain refers to the ability to send multiple data streams in parallel and to separate them on the basis of spatial signature.

1.5.1.1 MIMO signal model

Let \mathbf{Y} be a matrix of size $N \times T$ denoting the set of (possibly pre-coded) signals being transmitted from N distinct antennae over T symbol durations, where T is a parameter of the MIMO algorithm. Thus the n^{th} row of \mathbf{Y} corresponds to the signal emitted from the n^{th} transmit antenna. Let \mathbf{H} denote the $M \times N$ channel matrix modeling the propagation effects from each of the N transmit antennas to any one of M receive antennas, over an arbitrary subcarrier. We assume \mathbf{H} to be invariant over T symbol durations. Then the $M \times T$ signal \mathbf{R} received over T symbol durations over the subcarrier can be conveniently written as

$$\mathbf{R} = \mathbf{H}\mathbf{Y} + \mathbf{N},$$

where \mathbf{N} is the additive noise matrix of dimension $M \times T$ over all M receiving antennae. We will use h_i to denote the i^{th} column of \mathbf{H} , which will be referred to as the 'receive' spatial signature of the i^{th} transmitting antenna. Likewise the j^{th} row of \mathbf{H} can be termed as the spatial signature of the j^{th} receiving antenna.

1.5.2 Air Interface - OFDM

The choice of an appropriate modulation and multiple-access technique for mobile wireless data communications is critical to achieving good system performance. In particular, typical mobile radio channels tend to be time variant and dispersive, so this has generated interest in multi-carrier modulation.

Orthogonal Frequency Division Multiplexing (OFDM) is a special case of multi-carrier transmission which is highly attractive for implementation. In OFDM, the non-frequency selective narrowband sub-channels into which the frequency-selective wideband channels are divided are overlapping but orthogonal. This avoids the need to separate the carriers by means of guard bands, and therefore makes OFDM highly spectrally efficient. The spacing between the sub-channels in OFDM is such that they can be perfectly separated at the receiver. This allows for a low-complexity receiver implementation, which makes OFDM attractive for high-rate mobile data transmission such as the LTE downlink. The LTE downlink combines OFDM with channel coding and Hybrid Automatic Repeat reQuest (HARQ) to overcome deep fading which may be encountered on the individual sub channels.

In OFDM, the high-rate stream of data symbols is first serial-to-parallel converted for modulation onto M parallel subcarriers. This increases the symbol duration on each subcarrier by a factor of approximately M , such that it becomes significantly longer than the channel delay spread. This operation has an important advantage of requiring a much less complex equalization procedure in the receiver, under the assumption that the time-varying channel impulse response remains substantially constant during the transmission of each modulated OFDM symbol.

A key operation in the generation of an OFDM signal is the creation of a guard period at the beginning of each OFDM symbol to eliminate the remaining impact of ISI caused by multipath propagation. The guard period is obtained by adding a Cyclic Prefix (CP) at the

beginning of the symbol. The CP is generated by duplicating the last G samples of the IFFT output and appending them at the beginning of the respective symbol.

To avoid ISI completely, the CP length G must be chosen to be longer than the longest channel impulse response to be supported. The CP converts the linear convolution of the channel into a circular one which is suitable for DFT processing. The output of the IFFT is then Parallel-to-Serial P/S converted for transmission through the frequency-selective channel. At the receiver, the reverse operations are performed to demodulate the OFDM signal.

Chapter 2

Long Term Evolution - Advanced

2.1 Introduction

LTE-Advanced is intended to support further evolution of LTE and to establish E-UTRAN as an IMT-Advanced technology. LTE-A also known as LTE release 10 is set to provide higher bitrates in a cost efficient way and at the same time also focus on higher capacity:

- Increased peak data rate DL 3Gbps, UL 1.5Gbps
- Increased number of simultaneously active subscribers
- Improved performance and higher spectral efficiency
- Worldwide functionality and roaming
- Compatibility of services
- Inter working with other radio access systems

To achieve these goals, several enhancements are being considered. At the physical layer, LTE is expected to provide substantial improvement in peak, average and cell-edge spectral efficiencies, under the assumption of 8x8 antenna configuration in the downlink and 4x4 in the uplink. Under the same assumptions, peak spectral efficiency of 30 and 15bps/Hz should be met for the downlink and uplink respectively. Some of the physical layer enhancement techniques are Carrier Aggregation, Co-Ordinated Multipoint, Relays, uplink and downlink spatial multiplexing up to 4 and 8 transmit antennae respectively.

Small cells such as picocells and femtocells bring the network closer to users and provide a big leap in performance. But LTE-Advanced optimizes small cell performance through features such as 'Range Expansion' to make the leap even more significant. Simply adding small cells to a network only benefits users close to the cell, but LTE-A enhances the users experience for all the users including those on the cell edge with higher data rates, even when the small cells are not positioned in optimal locations. Additionally, the advanced receivers allow devices to discover small cells early and further increase performance of range expansion.

To achieve the requirements set by LTE-A, support for wider transmission bandwidths, other than the 20MHz bandwidth set aside for LTE specified in 3GPP release 8/9, is required. The preferred solution to this is Carrier Aggregation (CA). It is one of the most distinct features of LTE-A. CA allows the expansion of effective bandwidth delivered to a user terminal through concurrent utilization of radio resources across multiple carriers. Multiple component carriers are then aggregated to form a larger transmission bandwidth. LTE-A can aggregate up to 5 carriers (up to 100MHz) to increase user data rates and capacity for busy applications. The Aggregation(s) when combined with higher order MIMO can provide extremely high data rates.

2.2 Femtocells

Femtocells, also known as 'home base station', are cellular network access points that connect standard mobile devices to a mobile operator's network using residential DSL, cable broadband connections. It is a low-power access point, based on mobile technology, providing wireless voice and broadband devices to customers in the home or office environment.



Fig 2-1 Typical Femtocell

A femtocell incorporates the functionality of a typical base station or an eNB in the LTE standard. It comes along with a RNC (Radio network controller) and all the core network elements. Thus it does not require a cellular core network; only a data connection to the DSL or cable to the Internet is needed. In practice, the femtocell may be either a stand-alone device, which connects into the customer's existing broadband router or may form a key component of a home gateway device which incorporates the router and other technologies.

Typically, a single femtocell will deliver voice services simultaneously to at least 4 users (at the same time-means the same as simultaneously). Additionally they will also deliver data services to multiple users, typically at the full peak rate supported by the relevant air interface technology.

Femtocells use fully standard wireless protocols over the air to communicate with standard mobile devices, including mobile phones and a wide range of other mobile-enabled devices. They operate in spectrum licensed to the service provider, allowing operators to provide assured QoS (Quality of Service) to customers over the air. They have a high degree of intelligence to automatically ensure that they operate at power levels and frequencies that are unlikely to create interference.

2.3 Carrier Aggregation

To achieve LTE-Advanced requirements, support of wider transmission bandwidths, other than the 20MHz bandwidth specified in 3GPP release 8/9, is required. The preferred solution to this is the use of Carrier Aggregation (CA) technology. Since LTE-A must provide spectrum compatibility to legacy users, support for wider bandwidth in LTE-A is provided through aggregation of multiple component carriers.

3GPP specifies carrier aggregation in LTE as follows:

- Rel-8/9 backward compatible carriers are the basic building blocks and are to be supported
- Rel-10 signaling to support aggregation of up-to 5 downlink of component carriers and 5 uplink component carriers, irrespective of inter- or intra-band
- Rel-10 to support both intra- and inter-band aggregation for both DL and UL in FDD
- Rel-10 to support inter-band aggregation with different signal reception timings across component carriers of different bands for FDD DL
- UE-specific asymmetric number of component carriers in DL and UL
- Component Carriers can have any of the bandwidths supported in Rel-8

In addition to the increase in spectral efficiency, substantial reduction in latency is also targeted. The goals are to reduce the transition time from idle to connected mode in less than 100ms in LTE to 50ms. Similarly, the transition from dormant to active should be reduced from 50ms in LTE to 10ms.

Three types of CA technique have been proposed for the LTE-Advanced mobile systems and are introduced as follows:

- Continuous Carriers when multiple available component carriers are adjacent to each other
- Non-Continuous Intra-band carriers when multiple available component carriers are separated in the same band
- Non-Continuous Inter-band carriers when multiple available carriers belong to different frequency bands

Each component carrier may appear as a LTE carrier to legacy users while LTE-A users are able to transmit and receive on several component carriers simultaneously. Three possible aggregation scenarios are possible: contiguous and non-contiguous aggregation of component carriers in a single band and non-contiguous aggregation of component carriers over multiple bands. Prioritized deployment scenarios for LTE-A are proposed. In case of aggregation over multiple bands, they should be in a similar frequency range so that the hardware can be compatible.

For aggregation of non-contiguous component carriers, each carrier should meet existing LTE spectrum requirements such as emission mask, adjacent channel leakage and spurious emission to provide backward compatibility and to ensure minimal interference to adjacent carriers. In case of contiguous carriers, however, a large guard band is not necessary. By removing or relaxing the guard band, a much more efficient usage of the spectrum can be attained.

Since OFDM has a good spectral efficiency and robustness to highly dispersive fading channels, the LTE advanced systems adopted the OFDMA as downlink multiple access method. OFDMA takes modulation format as OFDM and the data to each user is passed simultaneously in different sub-carriers in each OFDM symbol. This exploits the multi-user diversity by means of dynamically scheduling users on frequencies with good channels.

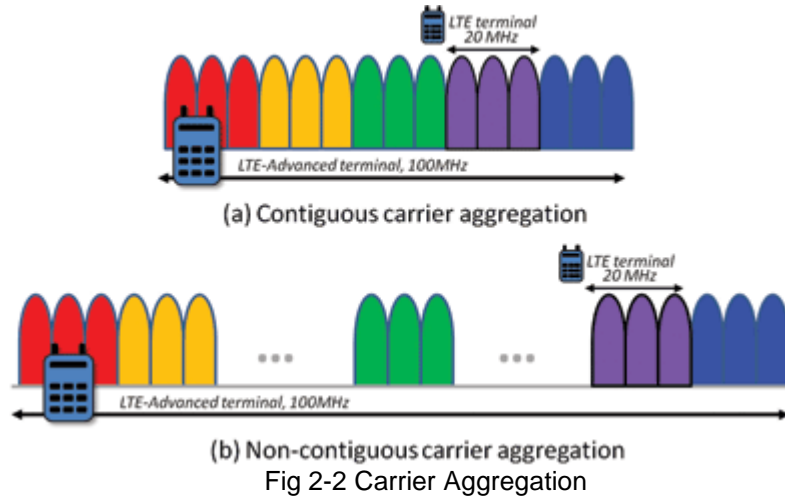

2.4 Co-Ordinated Multipoint Transmission/Reception

2.4.1 Introduction

Recently, the academic institutions have put in great effort to improve the spectral efficiency and data throughput of LTE systems. In many cases, the achievable cell spectral efficiency is limited by the inter-cell interference. Therefore Co-Ordinated multipoint Transmission (CoMP) was introduced in the LTE-A technology to relax performance limitations. Many of the facilities are still under development and may change as the standards define the different elements of CoMP more specifically.

This technology is essentially a range of different techniques that enable the dynamic coordination of transmission and reception over a variety of different base stations. The aim is to improve the overall quality for the user as well as improve the utilization of the network. Essentially, the LTE Advanced CoMP turns the Inter-Cell Interference (ICI) into a useful signal, especially at the borders where performance may be degraded.

Although this technique is a complex one, it has a lot of benefits:

- Makes better utilization of the network: By providing connections to several base stations at once, using CoMP, data can be passed through the least loaded base stations for better resource utilization.
- Provides enhanced reception performance: Using several cell sites for each connection means that the overall reception will be improved and the number of dropped calls should be reduced.
- Interference reduction: By using specialized combining techniques, it is possible to utilize the interference constructively rather than destructively thereby reducing interference levels.
- Multiple site reception increases power: The joint reception from multiple base stations or sites using LTE CoMP enables the overall received power at the handset to be increased.

CoMP can to some extent be seen as an extension of the inter-cell interference coordination, which is already present in LTE Rel-8. In LTE-A, the coordination can be in terms of the scheduling at different cell sites, thereby achieving an even more dynamic and adaptive inter-cell interference coordination. Alternatively, or as a complement, transmissions can be carried out to a mobile terminal jointly from several cell sites, thereby not only reducing the interference but also increasing the received power. The transmission from the cell sites can also take the instantaneous channel conditions into account, thereby achieving multi-cell beam-forming or precoding gains.

The basic idea behind CoMP is to apply tight coordination between the transmissions at different cell sites, thereby achieving higher system capacity and, more importantly, improved cell-edge data rates. Coordination schemes can be divided into two categories, used either alone or in combination. Dynamic scheduling coordination between multiple cells: Joint

processing occurs where there is coordination between multiple entities – base stations – that are simultaneously transmitting or receiving to or from UEs.

Joint transmission/reception from multiple cells: is a form of coordination where a UE is transmitting with a single transmission or reception point – base station. However the communication is made with an exchange of control among several coordinated entities.

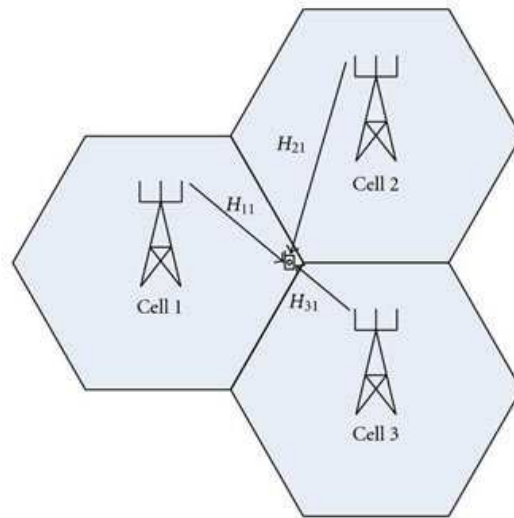

Fig 2-3 Illustration of CoMP

2.4.2 The CoMP Architecture

Coordinated multipoint transmission and reception refers to transmission/reception of the data to/from user equipments located at multiple cells. CoMP coordinates base station antennae deployed at a number of sites which are in feasible proximity to each other [4]. CoMP in LTE-A context includes various possible coordinating schemes among access points. The 3GPP technical report on further enhancements of E-UTRA physical layer aspects offer two major categories in CoMP scheme which are namely Coordinated Scheduling/Beamforming (CS/CB) and Joint Processing (JP) [6] which are explained below. eNBs should be in coordination to reduce the inter-cell interference in the system for both uplink and downlink. LTE requires the information of radio resource allocation, related to the reference UE to be available at all base stations in the coordination cluster. Therefore the latency of the links should be very

low so that the necessary coordination information can be exchanged in a very short time frame. There are two kinds of architecture described in [11], each of which can be combined with any of the transmission schemes mentioned above.

2.4.2.1 Centralized Architecture

A central unit is required to gather the information of all the UEs in the area covered by the base stations, eNBs in this case. The unit is also responsible for signal processing operations such as precoding and user scheduling. Moreover, what is crucial in centralized approach is the requirement of tight time synchronization among eNBs. At FDD systems such as 4G femtocell network, the downlink channel is known by the UE so that the UE can feed back the channel coherent or non-coherent indicators (CSI/CQI) in order to help eNB. The communication links between the central unit and the eNBs are the main challenges of this architecture. The links have to support low latency data transmissions and the protocols should be well designed for information exchange.

2.4.2.2 Distributed Architecture

Distributed architecture is another method to establish the coordination among eNBs, lessening the requirements of centralized approach. Assuming all the eNBs are identical in terms of scheduling and the channel information within the entire coordination set, cooperation does not need the wireless communication links between the nodes any longer. Thereby, the signaling protocol drawback and infrastructure load related to these links are minimized. The channels from all nodes are estimated by the users as in a centralized design. Then the scheduling is independently executed after these estimations are sent back to the cooperating nodes. Since the eNBs are identical in terms of scheduling, the same input parameters that will control the cooperation algorithm produce the same output decisions and therefore the same UEs are selected in the entire eNB cluster.

The main disadvantage of this approach is the reduction in the efficiency of CoMP algorithm when the eNBs are not cooperating via a wired backhaul. A lot of time could be spent

in reaching the state of convergence for the femtocells. Another drawback can be stated as the difficulty in error handling on different feedback links.

2.4.3 CoMP Schemes

2.4.3.1 Coordinated Scheduling/Beamforming

In coordinated scheduling /beamforming scheme, the data at the terminal is received from one of the base stations and coordination takes place among a set of base stations in order to control and coordinate the interference at the terminal. The coordinated scheduling is achieved by silencing the base stations with critical interference towards the victim UE and only allows transmission from serving BS. In other words, mobile station MS1 receives the intended data from only one base station, say BS1; however, another base station, say BS2, selects its own UEs in such a way that it causes little interference to the MS1. This method is known as an Interference mitigation method.



Fig 2-4 Co-Ordinated Scheduling/BeamForming

The method can be described analytically in the following scenario [12]. Assume there exists two mobile terminals, MS_1 and MS_2 and they are served by MS_1 & MS_2 . The received signals by BS_1 and BS_2 are denoted as Y_1 & Y_2 . H_{ij} is the channel gain from BS_i to MS_j and W_i is the precoding matrix at BS_i . X_i is the signal transmitted and N_i is the additive white noise.

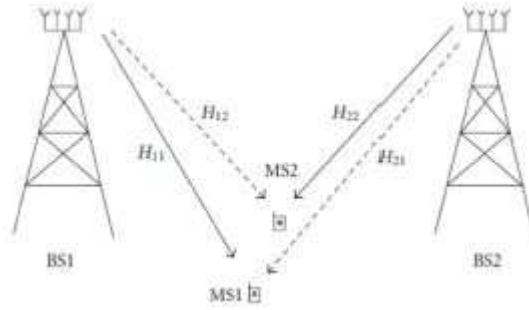

Fig 2-5 System model of two interfered users

$$Y_1 = H_{11}W_1X_1 + H_{21}W_2X_2 + N_1$$

$$Y_2 = H_{12}W_1X_1 + H_{22}W_2X_2 + N_2$$

According to the equation, the SINR at each mobile terminal can be expressed as

$$SINR_1 = \frac{||H_{11}W_1||^2P_1}{||H_{21}W_2||^2P_2 + N}$$

$$SINR_2 = \frac{||H_{22}W_2||^2P_2}{||H_{12}W_1||^2P_1 + N}$$

Where P_i is the transmitted power of X_i at BS_i . When mobile terminals are close to each other, $\{H_{11}, H_{12}\}$ and $\{H_{21}, H_{22}\}$ pairs are correlated. Hence, BS_1 creates large inter-cell interference at MS_2 and vice versa. In coordinated scheduling and beamforming, SINRs at mobile terminals are improved by modifying the precoding matrices, W_i . Briefly, this method is primarily used for reducing the inter-cell interference instead of improving the signal power received at the terminal.

2.4.3.2 Joint processing

As is described in [11] & [12], in Joint Processing (JP), multiple eNBs are responsible for the joint transmission of the data for a particular UE to improve the quality of the received signal and/or to cancel the interference for other terminals. Different cells share the data intended for a particular UE and the data is jointly processed at these cells. Hence, received signals are combined together at the mobile terminal coherently or non-coherently. JP is

categorized into two subcategories which are namely, Joint Transmission (JT) & Dynamic Cell Selection (DCS).

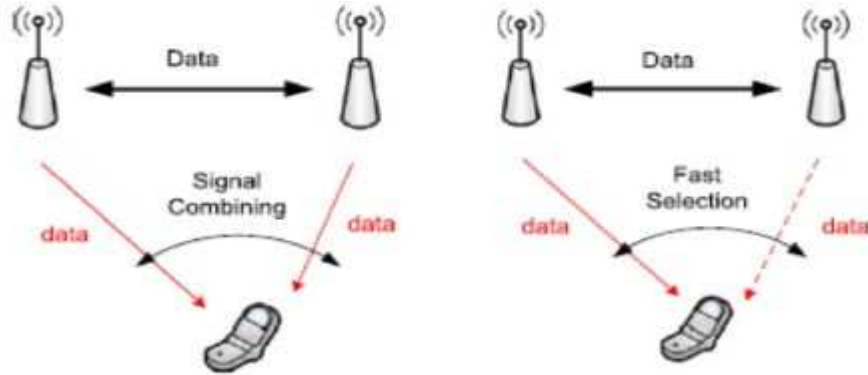

Fig 2-6 Joint processing Techniques: Joint Transmission & Dynamic Cell Selection

In DCS, a resource block of the Physical Downlink Shared Channel (PDSCH) is transmitted from one cell among the coordinated cells. This unique cell is dynamically selected by fast scheduling at the central base station, where the minimum path loss is considered. Meanwhile, the other cells do not transmit the resource block so that they do not cause interference to the user. As a result, the mobile terminal obtains the maximum received power and the interference from other users is significantly mitigated.

On the other hand, in JT, multiple cells among a cluster of coordinated cells transmit the same resource block of the PDSCH. JT is accomplished by codebook based pre-coding in order to reduce overhead of the feedback signal. Basically, in addition to the pre-coding matrix at each cell, the optimum pre-coding matrices for inter-cell coordination are chosen such that SINR is maximized at the mobile terminal.

Mobile station 1 MS_1 , receives signals from three different cells, C_1, C_2 and C_3 where three of them form a CoMP cluster.

$$Y_1 = H_{11}W_1X_1 + H_{21}W_2X_2 + H_{31}W_3X_3 + N_1$$

If each cell serves its own mobile user, the signals interfere with each other, so $SINR_1$ can be expressed as:

$$SINR_2 = \frac{\|H_{11}W_1\|^2 P_1}{\|H_{21}W_2\|^2 P_2 + \|H_{31}W_3\|^2 P_3 + N}$$

In a CoMP joint processing system, the mobile user is served by three of the cells in the CoMP cluster. Thus, $X = X_1 = X_2 = X_3$ and consequently;

$$Y_1 = (H_{11}W_1 + H_{21}W_2 + H_{31}W_3) * X + N_1$$

Then the SINR for MS_1 is:

$$SINR'_1 = \frac{\|H_{11}W_1\sqrt{P_1} + H_{21}W_2\sqrt{P_2} + H_{31}W_3\sqrt{P_3}\|^2}{N}$$

It is clear that $SINR'_1$ is an upper bound of $SINR_1$ and CoMP induces a SINR gain compared to a single cell operation [13]. Even though, cooperation of the cells has a positive impact on the user SINR, it also has an important drawback. $SINR_1$ is the result of a single cell operation; however, $SINR'_1$ is obtained under the assumption that three cells are serving one mobile terminal. Therefore, mobile terminals under CoMP joint processing occupy more system resources than the single cell ones. This is the most important cost of joint processing in CoMP.

Chapter 3

Femto Cells

3.1 Introduction

A typical approach to provide indoor coverage is to use outdoor macrocells. But this is very expensive using an 'outside in' approach. An indoor user with high penetration loss will need very high power from the base station; this will lead to less power allocation to other users thus reducing the overall capacity of the network. Hence the cost per Mb will become higher and more expensive. Also, the high capacity network needs to have lot of outdoor base stations, the acquisition of which has become very costly in highly populated areas. Due to the high cost, interference and also the power drain from base stations, this kind of architecture is not very feasible.

Hence indoor solutions become very important to provide high data rates to the user. There are several indoor concepts such as DAS (Distributed Antenna Systems), picocells. These are operator deployed and improve the indoor solution to a large extent. Though these are cost efficient and solve the purpose, they can still be expensive for scenarios such as SOHO (Small office and home office) and home users (for personal communications and entertainment.)

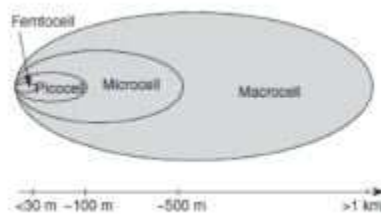

Fig 3-1 Comparison of cell sized for different cells

The new indoor solutions, Femtocells, are very important as they can provide indoor coverage effectively even for above mentioned scenarios. This gives the user continuous connectivity to the network without the loss of signal. It can offload traffic from the macrocell

layer and improve the macrocell capacity thus saving the need to compensate for high penetration loss and more power from the macro base station.

There is a growing need for higher and higher data rates. Due to high penetration loss, high data rate services cannot be provided at indoor environments barring a few scenarios. This is because the high data rate requires high performance RF links. High data services such as those facilitated by HSDPA and LTE are the key drive of femtocells. They can provide significant power saving to the UEs. Battery life is one of the biggest bottlenecks for providing high speed data services to mobile terminals.

The power consumption of the base stations accounts for the considerable amount of an operator's OPEX. A base station consumes far more power than that used for transmitting and receiving signals. Femtocell provides an ideal solution for FMC (Fixed Mobile Convergence). It represents a major paradigm shift; users will pay to install femtocells. Hence, the first phase of the rollout of high data rate networks such as LTE can start from indoor where the high data rates are needed most.

3.2 FemtoCell Architecture

The current 3G architecture is hierarchical. It consists of the macrocell node connected to the Radio Network Controller (RNC). The RNC is connected to tens to hundreds of base stations. The RNC performs radio resource management and handovers between base stations and also is connected to the Mobile Switching Center (MSC), the Serving GPRS Support Node (SGSN) and the Gateway GPRS Support Node (GGSN). The MSC is connected to the Public Switched Telephone Network (PSTN) and to several RNCs. The SGSN and GGSN support mobile data services, routing protocols and security issues in a typical 3G system. Consider LTE case, the developments also necessitates a reduction in the network architecture of femtocell systems.

The standardization of femtocells / Home ENodeBs (H-eNB) in LTE networks is conducted by 3GPP with TR R3.020 Rel-8. Regarding the different demands of different

operators, the initial Radio Access Network (RAN) centric solution is evolved along with developments in LTE. The standardization processes try to integrate femtocells into the Evolved Packet Core (EPC) infrastructure using the same EPC. The LTE EPC is based on flat IP architecture and so are the femtocell's and microcell's' architecture and interface. New interfaces between LTE femtocells and EPC elements are redundant.

The ultimate evolution of femtocell access network architecture is shown in the figure 3-2. Depending on how a femtocell gateway is placed, various ways of connecting HeNBs to the core network exist. From a logical point of view, the X2 is a point-to-point interface between eNodeBs within E-UTRAN.

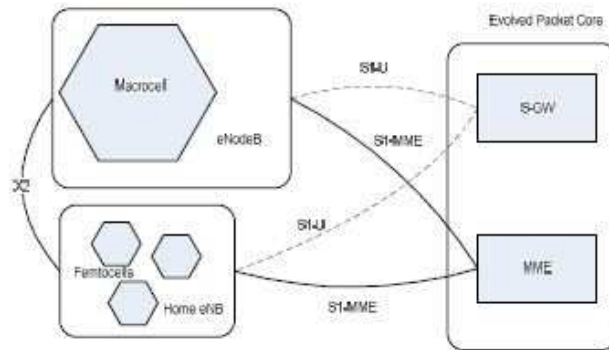

Fig 3-2 Simplified Diagram of LTE Femtocell Network

S1 interface connects LTE femtocells to the MME and S-GW directly in case of absence of a femto gateway, assuming that MME & S-GW have sufficient capacity to support large numbers of femto S1 interfaces. In installations with a Control Plane (CP), the femto gateway only aggregates CP traffic from multiple FAPs to the MME. Installations with a CP and User Plane (UP), the femtocell gateway aggregates both CP traffic from femtocells to the MME and UP traffic from femtocells to the S-GW [14].

3.3 Deployment of Femtocells & their Challenges

When seen from the Operator's perspective, a large amount of traffic (70-80%) can be offloaded from macrocells. This means that there will be fewer outdoor macrocells which will reduce huge CAPEX saving for operators in their radio access networks. The reduction of traffic

from macrocell sites will also result in significant saving in the backhauling. This will also lead to associated saving on the OPEX. Additionally this will simplify the site survey and planning process; it also means less rent will be paid for the usage of base station sites. Femtocells are low cost indoor solutions when compared to the outdoor macrocells. Secondly users will share a substantial amount of the installation, thus reducing cost in the larger picture by manually installing them at their homes. Femtocells also will improve the network coverage and service quality; hence it will improve customer churn.

From the Subscriber's perspective, femtocells can provide indoor coverage to those users who have poor coverage or no coverage at their home. In addition to voice service, multimedia, video and high data services will also become available. Femtocells also offer using a single address book and one billing account for landline, broadband and mobile phone. Users can benefit from such a scheme and it will turn out to be a lot more cost effective than using services from more than one provider. They will deliver converged services (video, voice and data services) at home and enable users to have a seamless user experience across both outdoor and indoor environments with personalized converged services for UEs.

As we have seen, there are many reasons why customers and operators are demanding femtocells, the services and economies that can be provided by using them. Yet there are some challenges posed by them.

Radio Challenges:

- Interference between femto- and macro cells;
- Radio resource and mobility management.

Network Challenges:

- Architecture and Interfaces;
- Scalability;
- Security.

Market Challenges:

- Public Awareness, public concerns regarding service, tariffs;
Support for a wide range of use cases.

3.4 Industry Activity

Femto forum is a non – profit organization founded in 2007 to encourage the deployment of femtocells worldwide. Service providers, mobile operators, hardware and software vendors and start-ups are the associates of this community. Femto forum has strong connections with other industrial communities such as GSM Association, 3GPP, 3GPP2 and Wimax forum.

In conventional 2G & 3G systems, femtocells are implemented on top of existing cellular networks. In WiMAX forum, service providers have started working on the requirements for femtocells from perspective of network operators together with the improvements in 4G systems. Several service providers are planning to introduce femtocells into their networks to improve the throughput of the current users.

In 2002, Motorola evolved the world's smallest full – function UMTS femtocell base station. In 2005, providers such as Samsung, Alcatel-Lucent, Airwalk, picoChip, etc. widely acknowledged the idea of femtocells. Femtocell systems were demonstrated at the cellular industry 3GSM conference in 2007. Sprint Nextel initiated a limited rollout of femtocells deployed by Samsung which operate with any Sprint handset. Ericsson, NEC, Samsung, Nokia Siemens Networks, Airvana, Qualcomm are the companies that have launched 3G femtocell base stations [14].

3.5 Radio Issues for Femtocells

One of the defining characteristics of a femtocell is its use of licensed spectrum. Typically this spectrum is already in use for delivering services using the existing macrocells. So, operators may need to have the confidence that femtocells can operate without creating harmful interference with the existing network, even when deployed entirely by the end-user.

One of the issues to be considered is that of CSG (closed subscriber group) versus open access. Open access is the normal manner in which macrocells operate, where all subscribers registered with an operator can access all base stations. Thus all subscribers are subject to power control to ensure that they do not transmit at excessive power levels, and all receive service from multiple base stations when they are in areas of overlapping coverage, thereby avoiding interference between macrocells. CSG is the most common approach used in femtocell technology. Other users will potentially be subject to interference from femtocells when they are in poor coverage areas from macrocells but close to femtocell. They may also cause interference with/in the femtocell, when they are transmitting at high power to reach a distant macrocell, but are standing close to a femtocell, thereby drowning out a weak femtocell user. There is also interference between macro and femto cells; given that there are so few distinct carriers, operators may not have the opportunity to deploy femtocells in a dedicated spectrum.

In order to analyze the performance of a femtocell, it is important to determine models of radiowave propagation in typical femtocell environments. Most studies of indoor propagation have focused on larger buildings, such as public buildings and large offices, rather than on the home or small office locations, which will be the main environments for femtocells. The model recommended by ITU-R for the path loss between indoor terminals, known as ITU-R P.1238 is given as

$$L_{50}(r) = 20 \log f_c + 10n \log r + L_f(n_f) - 28$$

where n is the path loss exponent and $L_f(n_f)$ is the floor penetration loss, which varies with the number of penetrated floors n_f .

Chapter 4

Interference Scenarios

4.1 Introduction

Femtocells will provide higher spectral efficiency, spatial frequency reuse and better coverage in areas not fully covered by macrocells. However, if interference cancellation or avoidance techniques are not applied, dead zones can appear within the macrocell, disrupting its service in the proximity of a femtocell.

4.1.1 Co-Layer Interference

Co-Layer interference is described as the unwanted signal received at a femtocell and sent from other femtocells, decreasing the quality of its communication. The name co-layer makes reference to the fact that all femtocells belong to the same network layer, unlike other elements like base stations, NodeBs and so on, which belongs to the macrocell layer. Co-Layer interference occurs mainly between immediate neighbors due to low isolation between houses. This problem is independent of the problem caused at macrocell layer.

Since the deployment of femtocells is opportunistic, it is likely that several femtocells would be installed in locations close to each other. Let us assume that a Global System Mobile (GSM) femtocell f_a illuminates an arbitrary location L_a . It can be said that L_a belongs to the coverage area of f_a . If there are additional signals from surrounding femtocells using the same frequency, location L_a is said to suffer from co-channel interference and the system's performance suffers. Furthermore, when signals from several femtocells are present at a given location, the overall interference can be higher than any of the independent femtocell power levels. The degradation of the communication varies between RF technologies due to their different performances in the presence of interference.

The femtocells can be deployed in Closed Subscriber Group (CSG), open-access or in a hybrid mode, the impact of the co-layer interference will be different depending on the access method. If all the femtocells within the same area are synchronized, the aggressors (another

name for interfering sources according to 3GPP standards) at an interfered femtocell user are the neighboring FAPs during downlink. This means that transmissions coming from a FAP will cause interference to UEs of neighboring femtocells in downlink only. In the case that no synchronization existed between femtocells, the source of interference in TDD would be undetermined. The uplink and downlink periods of different femtocells would overlap and introduce heterogeneous sources of interference. This way, neighboring femtocells would overrun each other's transmission time slots and make interference harder to control. Since all MBS belong to the same network layer, the interference between different macrocells is also a cause of co-layer interference. However, the deployment of macrocells is planned by the operator, with interference being dealt with by means of planning schemes. This problem is thus independent of the deployment of femtocells.

In downlink co-layer interference, the FAPs are the aggressors or sources of interference, while UEs of neighboring femtocells are the victims. Co-channel downlink interference is one of the main sources of impairment for femtocells. Since femtocells will be deployed in close positions relative to each other, they are very likely to interfere with one another by means of power leaks from windows, doors and poorly isolated walls. The signals of several femtocells within the same area contribute to raising the interference. Hence in CDMA systems, the noise level increases and creates dead zones where downlink connectivity becomes impossible. To prevent femtocells from causing interference in the downlink to UEs of nearby femtocells, the most commonly used method is to be careful about the transmitting power levels by using adaptive power control techniques. This is necessary especially in CSG femtocells as the UEs are not necessarily served by the strongest FAP but by the one to which they are subscribed. A case of co-layer downlink interference occurs when a given femtocell user is located in an area within FAP premises, where the signal coming from its own femtocell is not high enough compared to the interference coming from surrounding femtocells.

However in OFDMA systems, the allocation of the sub-channels at each femtocell plays a decisive role in the final impact of the interference. Dead zones in OFDMA femtocells depend on the spectrum occupancy at a given location. Two femtocell users could be at the same geographic position and only one of them would suffer interference from surrounding femtocells. The allocation of frequency resources is thus extremely important in OFDMA femtocells.

4.1.2 Cross-Layer Interference

In two-layer networks, an interfering signal is assumed to produce cross-layer interference if the aggressor and the victim systems belong to different layers of the network. For example, the distortion caused by an emitting FAP at the downlink of one or several macrocells is a clear case of cross-layer interference. Likewise, it can also be considered as cross-layer interference if the distortion is caused by a macrocell user at the uplink of a nearby FAP. Cross-layer interference is a problem especially in CDMA co-channel deployed two-layer networks, due to the fact that both femtocells and macrocells use the same frequency band. Besides, due to power control, sudden high transmitting powers can cause the appearance of dead zones, thus reducing the feasibility of these networks.

Spectrum splitting has been proposed as a means of coping with the cross-layer interference. However, given the cost and scarcity of the electromagnetic spectrum, this would lead to a less efficient frequency reuse. Spectrum splitting would almost remove all the cross-layer interference. However, when both bands are adjacent in the frequency domain, the adjacent channel can also introduce interference, which is why the Adjacent Channel Interference Rejection Ratio (ACIR) needs to be minimized when designing the transmit power limits. The ACIR is defined as the ratio of the total power transmitted from the aggressor to the total interference power affecting the victim. It is mathematically expressed as:

$$ACIR = \frac{1}{\frac{1}{ACLR} + \frac{1}{ACS}}$$

where the Adjacent Channel Leakage Ratio (ACLR) measures the ratio of the average power sent into adjacent channels by the transmitter due to imperfect filters, to the average power actually sent into the assigned channel. Furthermore, the Adjacent Channel Selectivity (ACS) measures the ratio of the receiving filter attenuation on the assigned band to the attenuation on the adjacent channel. Even in split-spectrum deployments, the achievable ACIR is limited. Hence, the power of the FAP and the UEs must be regulated to limit the impact on the macrocell.

In OFDMA systems, the spectrum is divided into subcarriers, so OFDMA based femtocells are a desirable solution, offering high versatility for the handling of cross and also co-layer interference. However, OFDMA systems can also suffer other types of problem such as frequency and time synchronization issues. Interference from other elements of the network could introduce inter-carrier interference due to frequency offsets, thus resulting in the loss of orthogonality between subcarriers and so bringing down the entire system.

Chapter 5

System Simulator

5.1 System Architecture

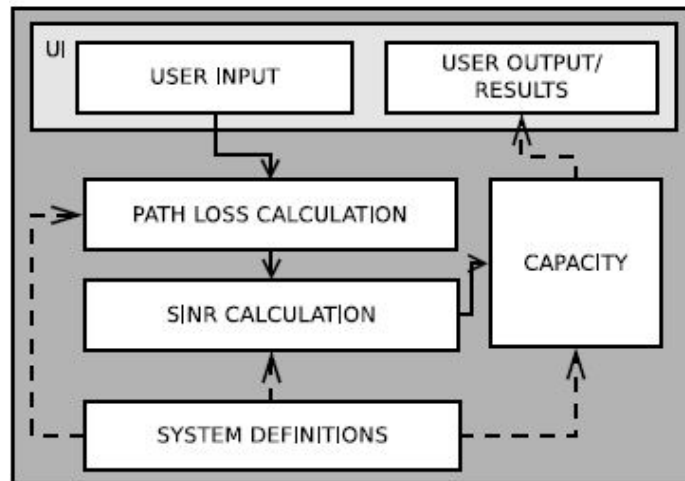

Fig 5-1 System Architecture

Considering all the mathematical formulae, the simulation framework has been designed [15]. The architecture of the system has been shown above. It is primarily divided into two layers; the upper layer is reflected by the graphical user interface which is used both for the input and output. This layer is used for defining the parameters of the topology i.e. number of femtocells, number of femtocell users and number of macrocell users.

The lower layer is a reflection of the mathematical model used in the simulator, the calculation of pathloss, SINR calculation and the throughput calculation along with various modulation schemes used is defined in this layer. The architectural elements are divided into:

- User Input module
- Path loss estimation module
- SINR estimation module
- Capacity calculation module
- User output module

5.1.1 User Input Module:

The user communicates with the system via a graphical user interface. For appropriate calculations to be made, the frame work needs the following user input such as:

- Location coordinates of the femto BSs in a macrocell area
- Total number of femto and macro users and the femto BSs the users attached to.

Due to multiple configuration modes available in the LTE-A the total base station bandwidth and the modulation scheme parameters are necessary. Based on the given local coordinates, the distance between UE's and respective antenna spots are calculated, resulting estimation of the channel path loss. The topology considers only the case of an urban area since the deployment of femto BS in other types of areas is not common and therefore due to their density they do not present scientific interest.

5.1.2 Path loss Estimation Module:

The analysis and modeling performed by this module is described in the further sections. This module implements the mathematical models provided by 3GPP – TR 36.814 V9.00 standard, corresponding to all possible cross-tier and intra-tier interference and deployment scenarios that can take place in an urban area. Those cases include:

- Outdoor macro user interfered by femto BS
- Indoor macro user interfered by femto BS
- Outdoor femto user interfered by macro BS
- Indoor femto user interfered by macro BS

The selection of the appropriate model is made, based on the user input of the previous module. Irrespective of the scenario selected, the result of this module, expressed in dB, is forwarded as input to the next module.

5.1.3 SINR Estimation Module:

This module implements the channel gain and various SINR calculation mathematical models. The Path Loss Estimation module provides the estimated path loss value to be used for channel gain calculation. This in turn provides the calculated value as it is necessary for the calculation of each user's channel gain.

5.1.4 Capacity Calculation Module:

This module implements only the channel capacity estimation model by taking into account the carrier spacing and the result provided by the SINR estimation module. The final results' matrix is given to the next module, so that it will be presented to the end user.

5.1.5 User Output Module:

When the user input is set and the simulation process is performed, the final results are displayed in the new window which presents the topology covered in every point, according to the throughput level. The simulator displays a map representing the user-defined topology. Next to the map there is a layer that displays the analytical properties of the unit hovered by the mouse pointer. After running the simulation for every possible position, the whole map is colored according to the throughput levels and a colored bar is displayed next to the map, representing the throughput values spectrum. By hovering the results window, the panel next to the map is updated with the corresponding analytical simulation values.

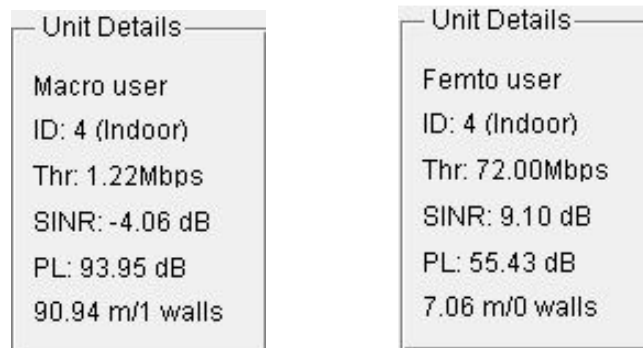

Fig 5-2 Analytical results of a sample macro user & a femto user

5.2 Analysis and Parameters

Channel models are one of the most important perspectives in the system design. All the possible scenarios are considered and mathematically formulated. This section presents the analysis that estimates the interference and throughput in every point of the LTE-A system consisting of macrocells and femtocells.

5.2.1 Path Loss Model

In order to estimate the SINR, first we need to calculate the path loss between a macro eNB and a UE that are in the same apartment stripe and between a femto eNB and a UE. The path loss for the first case and for a macro user roaming outdoor in the urban area, can be determined as:

$$PL(dB) = 15.3 + 37.6 \log_{10} R \quad (1)$$

Whereas, for the case of an indoor macro user the path loss is given by:

$$PL(dB) = 15.3 + 37.6 \log_{10} R + L_{ow} \quad (2)$$

Where R is the distance between the transmitter (T_x) and the receiver (R_x) in meters and L_{ow} is the penetration loss of an outdoor wall. The path loss between a femto base station and a UE is calculated by the following equation:

$$PL(dB) = 38.46 + 20 \log_{10} R + 0.7d_{2D,indoor} + q^*L_{iw} + 18.3n^{((n+2)/(n+1)-0.46)} \quad (3)$$

where, n is the number of penetrated floors, q is the number of walls separating the apartments between femto BS and the UE, and L_{iw} is the penetration loss of the wall separating apartments. Also the term $0.7d_{2D,indoor}$ takes account of penetration loss due to walls inside an apartment and is expressed in m.

Finally, the case of an outdoor femto user associated to an indoor femto eNB. In this case the outdoor wall loss is also considered as:

$$PL(dB) = \max(15.3 + 37.6 \log_{10} R, 38.46 + 20 \log_{10} R) + 0.7d_{2D,indoor} + q^*L_{iw} + L_{ow} + 18.3n^{((n+2)/(n+1)-0.46)} \quad (4)$$

5.2.2 SINR Estimation

The estimation of the received SINR of a macro user m on subcarrier k , when the macro user is interfered from neighboring macrocells and all the adjacent femtocells, is expressed as:

$$SINR_{m,k} = \frac{P_{M,k}G_{m,M,k}}{N_0\Delta f + \sum_{M'} P_{M',k}G_{m,M',k} + \sum_F P_{F,k}G_{m,F,k}} \quad (5)$$

where $P_{M,k}$ and $P_{M',k}$ is transmit power of serving macrocell M and neighboring macrocell M' on subcarrier k , respectively. $G_{m,M,k}$ is channel gain between macro user m and serving macrocell M on subcarrier k . Channel gain from neighboring femtocell are denoted as $G_{m,M',k}$. Similarly, $P_{F,k}$ is transmit power of neighboring femtocell F on sub-carrier k . $G_{m,F,k}$ is channel gain between macro user m and neighboring femtocell F on subcarrier k . N_0 is white noise power spectral density, and Δf is the subcarrier spacing.

In case of a femto user f on subcarrier k interfered by all macrocells and adjacent femtocells, the received SINR can be given as:

$$SINR_{f,k} = \frac{P_{f,k}G_{f,F,k}}{N_0\Delta f + \sum_{F'} P_{F',k}G_{f,F',k} + \sum_M P_{M,k}G_{f,M,k}} \quad (6)$$

The channel gain G is dominantly affected by path loss, which is different for outdoor and indoor scenarios (1), (2), (3) and (4). So it can be expressed, as:

$$G = 10^{-PL/10} \quad (7)$$

5.2.3 Throughput Calculation

After obtaining the SINR, throughput can be calculated. The practical capacity of macro user m on subcarrier k can be given as:

$$C_{m,k} = \Delta f * \log_2(1 + \alpha SINR_{m,k}) \quad (8)$$

where α is a constant for target Bit Error Rate (BER), and defined by $\alpha = -1.5/\ln(5BER)$. In this analysis BER is set to 10^{-6} . Finally, the throughput of serving macrocell M can be expressed as:

$$T_M = \sum_m \sum_k \beta_{m,k} C_{m,k} \quad (9)$$

where, $\beta_{m,k}$ represents the subcarrier assignment for macro users. When $\beta_{m,k} = 1$ means that the subcarrier k is assigned to macro user m . Otherwise, $\beta_{m,k} = 0$. In a macrocell, in every time slot, each subcarrier is allocated to only one macro user, this is known from the characteristics of the Orthogonal Frequency Division Multiple Access (OFDMA) system. So this implies that:

$$\sum_{m=1}^{N_m} \beta_{m,k} = 1 \quad (10)$$

where, N_m is the number of macro users in a macrocell.

5.2.4 Using the Simulator

The femtocell deployment process on the simulator is begun with the initial screen illustrated in the fig below:

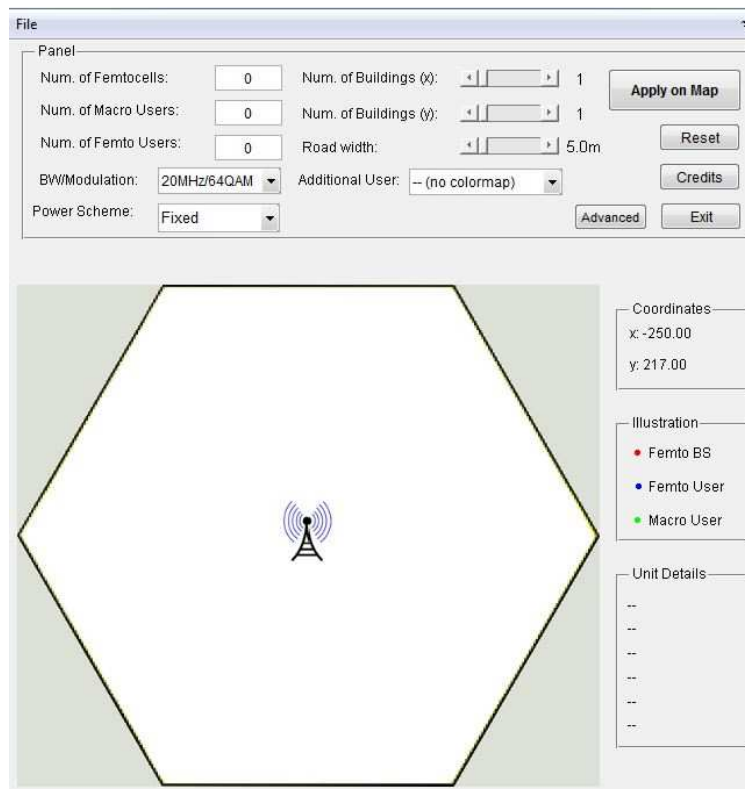

Fig 5-3 Initial Simulator Screen

The number of macro users, femto users and the number of femtocells deployed has to be entered. Apart from these parameters, number of building both long x axis, y axis and the preferred channel bandwidth according the current LTE-A standards (1.4, 3, 5, 10, 15 or 20 Mhz) needs to be provided. Also, because of the applied urban environment the user has to define the width of the map's streets, in meters. By clicking "Applying to Map", the buildings are set up accordingly. A manual femtocell deployment and femto/macro user placement takes place by clicking onto specific points in the macrocell's area. The deployment is considered completed when the end-user has placed the last macro user on the map. After this event, one can view the simulation statistics for every placed unit, by hovering that with the mouse pointer.

A sample scenario is presented in fig. 4 where I have considered 10 femtocells, 14 femtocell users and 8 macrocell users. The Bandwidth is chosen as 20Mhz and the modulation as 64QAM. The numbers of buildings are 16, with 4 in x axis and 4 in y axis. The road width is assumed to be default as 5.0m.

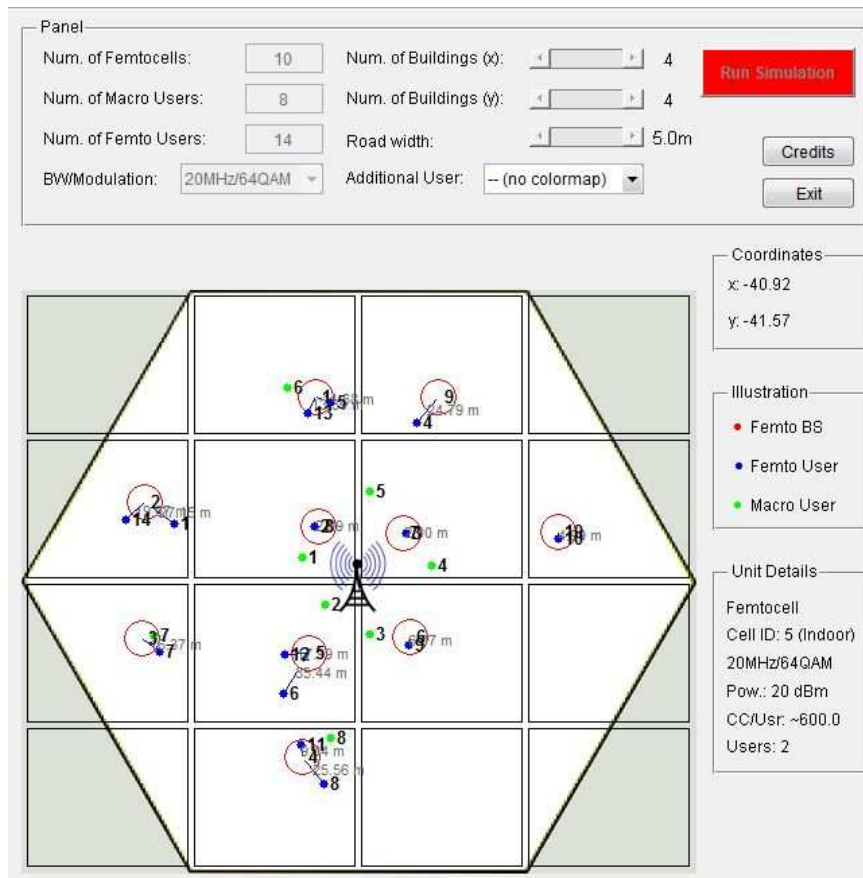

Fig 5-4 Sample illustration after the deployment is completed

5.3 Frequency Reuse Schemes

The Soft Frequency Reuse (SFR) scheme divides the coverage area of macrocell into two regions; center (interior) region and edge region. The center region is defined by a radius from the macro BS and this differs depending on the scenario and algorithm. SFR scheme divides the entire frequency band of the system equally into three sub-bands. The entire frequency band is accessed only by center MUEs during first time slot of LTE frame (When reuse factor is 1). The second time slot is reserved for edge MUEs. Edge MUEs at each sector can access one of the three frequency sub-bands (When reuse factor is 3). The transmission power level of the edge region is set to be three times the transmission power level of the center region.

Similarly to SFR, Partial Frequency Reuse (PFR) divides the coverage area into center and edge regions. PFR scheme divides the entire system bandwidth into 6 sub-bands. The first 3 sub-bands are reserved for center MUEs at any sector. These sub-bands are called Common Sub-bands. Each of the three remaining sub-bands is reserved for edge MUEs at different sectors. The transmission power level for sub-bands of the edge region is set to be $2/3$ of the total transmission power. The transmission power level for sub-bands of center region is set to be $1/3$ of total transmission power

Soft Fractional Frequency Reuse (SFFR) scheme can be considered a generalized case of the PFR scheme. The only difference between PFR and SFFR schemes is the available sub-bands accessed by center MUEs at each sector. Unlike PFR scheme, center MUEs in SFFR scheme can access all available sub-bands except the one reserved for edge MUEs of that sector.

5.3.1 Proposed Frequency Reuse Scheme

In the proposed scheme, the femtocell is characterized into center femtocell or edge femtocell. Depending on the above defined category the sub-bands are allocated. The center femtocells will be able to access all sub-bands except, those sub-bands which are utilized for the cell edge users in the current sector and the edge femtocells will be able to access all sub-bands, other than those which are utilized by the cell center users. The interference between femto user and macro user can be highly reduced, as at any given point of time the channel allocated to them are different, so this way the interference between these users if any will be kept to minimum. This way the sub-bands are not reserved and change dynamically according to the environment and will provide high spectral efficiency compared to other static and semi-static schemes.

5.4 Implemented Algorithm

When a H-UE is turned ON, it starts measuring the received signal from all the neighboring H-eNB's. After this it determines those H-eNB's from which it is most likely to have

interference. These values are sent back to the serving femto eNB and thus the femto eNB collects the information about all the allocated sub-bands and thus will allocated a sub-band which has not been used or the one on which it is experiencing the least interference. If all the sub-bands are not used up by the neighboring eNB's, then the non-overlapping orthogonal sub-band is allocated to the H-UE by the serving femto base station. The Received Signal Strength Indicator (RSSI) is used by the H-UE to determine the signal strength from various femto base stations. RSRP is a combination of Reference Signal Received Power (RSRP) and Reference Signal Received Quality (RSRQ). On the other hand, if no sub-band is available, the sub-band on which the highest interference is experienced is allocated to the H-UE. Highest interference means that the signal strength obtained by the neighboring H-eNB is very strong, so instead of trying to mitigate it, using CoMP it can be converted to the user's benefit, thus jointly coordinating to provide high throughput to the H-UE.

By using the above mentioned technique, the same sub-channel is allocated to the UE from which he is experiencing high interference; this mitigates the femto-femto interference to a large extent. As mentioned earlier, the user is allocated an unused sub-channel if available, the throughput of the user is maintained high in this case as he does not any interference from the neighboring H-eNB's.

Though the H-UE is allocated a sub-channel, the H-UE continuously measures the RSSI from the neighboring femtocells at various time intervals and these values are simultaneously fed back to the serving H-eNB. This way the serving H-eNB allocates more than 1 sub-carrier to the user, if the sub-carrier is not used by the neighboring cells, thus bringing CA into place. CA is used only when more than 1 sub-carrier is available at the femto base station's disposal.

5.5 Parameters Considered

Table 5-1 System Level Simulation Parameters

Parameter	Value
Macrocell Radius	250 m
Femtocell Radius	20 m
Macro BS Power	46 dBm
Femto BS Power	20 dBm
Outdoor Walls Loss	20 dB
Indoor Walls Loss	5 dB
Bandwidth	20/100Mhz
Modulation Scheme	64 QAM
Subcarrier Spacing	15 Khz

Chapter 6

Simulation & Results

6.1 Schemes Used

6.1.1 Conventional Scheme

SINR for each user j attached to cell i is calculated as:

$$SINR_{j,i} = \frac{P_i G_i PL_{j,i}}{\sum_{k=0, k \neq i}^N (P_k G_k PL_{j,k})}$$

Where $PL_{j,k}$ is the path loss between user j and femtocell k .

Further, Capacity is calculated as:

$$C_{j,k} = BW \cdot (1 + \alpha \cdot BER) SINR_{j,i}$$

Where BW is the total bandwidth (20Mhz) divided by number of users at the femtocell.

6.1.2 Proposed Scheme

6.1.2.1 Carrier Aggregation

Step 1: Initialization:

Each femtocell is assigned 1 sub-band (out of 10), if all the sub-bands are already taken, then the one with least interference is selected, based on measurement of total capacity from the 3 neighboring cells.

Step 2:

After the initial sub-band is assigned to the user by the serving femtocell, a check is performed if 1 more sub-band can be allocated (repeat for all sub-bands) at the same time checking if the capacity is increased within the 3 neighboring cells.

Step 3:

Repeat step 2 until there is no more change in the capacity across any femtocell neighborhood, or until the iteration limit is reached (Iteration limit 10 is used).

So SINR for each user j attached to cell i is calculated as:

$$SINR_{j,i} = \frac{P_i G_i PL_{j,i}}{P_i (IM_j \times SB) \times SB_i^T}$$

Where SB is the sub-band matrix having a value 1 where a particular sub-band is used by particular femtocell and a value 0 when that femtocell is not using that band. The matrix is shown as:

$$SB = \begin{bmatrix} 1 & \dots & 0 \\ \vdots & \ddots & \vdots \\ 0 & \dots & 0 \end{bmatrix}$$

The number of rows represents femtocell IDs (1...Number of femtocells) & the number of columns represent band IDs (1...Number of bands).

IM is an interference matrix defined as:

$$IM = \begin{bmatrix} G.PL & \dots & \\ \vdots & \ddots & \vdots \\ & & \dots \end{bmatrix}$$

The number of rows represent femtocell user IDs (1...Number of femtocell users) & the number of columns represent femtocell IDs (1...Number of femtocells).

In $(IM_j \times SB) \times SB_i^T$ the first multiplication produces a vector of sums over all interfering femtocells at user j as:

$$[[G1 * PL1 * SB(1,1) + G2 * PL2 * SB(2,1) + \dots], [G1 * PL1 * SB(1,2) + G2 * PL2 * SB(2,2) + \dots]]$$

Thus every element in the array produced by the first multiplication is a summation of interferences at a particular band. This is multiplied by a transposed band vector at the present femtocell i, producing sum of only those interferences which are using the same band as the present femtocell i. The capacity is thus calculated as:

$$C_{j,i} = BW(1 + \alpha SINR_{j,i}) \text{ where } \alpha = -1.5 / \log(5 * BER) \text{ and } BER \text{ is } 10^{-6}.$$

6.1.2.2 CA along with Co-Ordinated Multipoint Tx/Rx

To model the CoMP, the most interfering components of the Interference Matrix (IM) are removed. One value is removed for each femtocell, so that each femtocell supports 1 CoMP user. In reality more CoMP users per femtocell can be supported, but for the simplicity case 1 CoMP user per femtocell is considered. For each femtocell, a maximum value of interference is found across all the users. This femtocell and the user form a CoMP pair, which adds to the

throughput of that user, only at those points where the sub-bands coincide. SINR for each user j attached to cell i is calculated as:

$$SINR_{j,i} = \frac{P_i \cdot G_i \cdot PL_{j,i}}{(IM_{j,:} \times SB) \times SB_i^T} + \sum_{c=1}^{N_c(j)} \frac{P_c \cdot G_c \cdot PL_{j,c}}{(IM_{j,:} \times SB) \times SB_c^T}$$

where, c index represent those femtocells that provide CoMP to the user j . $N_c(j)$ represents the number of femtocells that can provide CoMP to user j . $N_c(j)$ is found by counting elements of another matrix, called CoMP-matrix, which is same dimension as the Interference Matrix, but has a value of either 1 or 0, representing yes or no scenario for particular user-femtocell combination if they form CoMP pair.

The Interference Matrix, IM, is modified from the one used in CA by zeroing the elements which correspond to the CoMP user-femtocell pair. The zeroed elements are chosen based on maximum value of interference, as calculated along all the users per each femtocell i.e. one zero for each femto cell, at the place of worst interference. Capacity is later calculated in the same way as for Carrier Aggregation.

6.2 Topology Used

Shown below in the fig 6.1 and fig 6.2 are the topologies used in the simulation. The Fig 6.1 represents 30 femtocells, along with 50 femtocell users and 5 macrocell users. There are 25 buildings, with 5 along the x axis and 5 along the y axis. The road width is taken approximately as 10 m. The modulation scheme used is 64 Quadrature Amplitude Modulation (QAM) and the bandwidth is 20MHz/ 100 MHz.

Fig 6.2 represents higher number of femtocell users, i.e. 50 femtocells, 120 femtocell users and 10 macro users. The numbers of buildings, road width, modulation scheme and the associated bandwidth parameters have been kept the same.

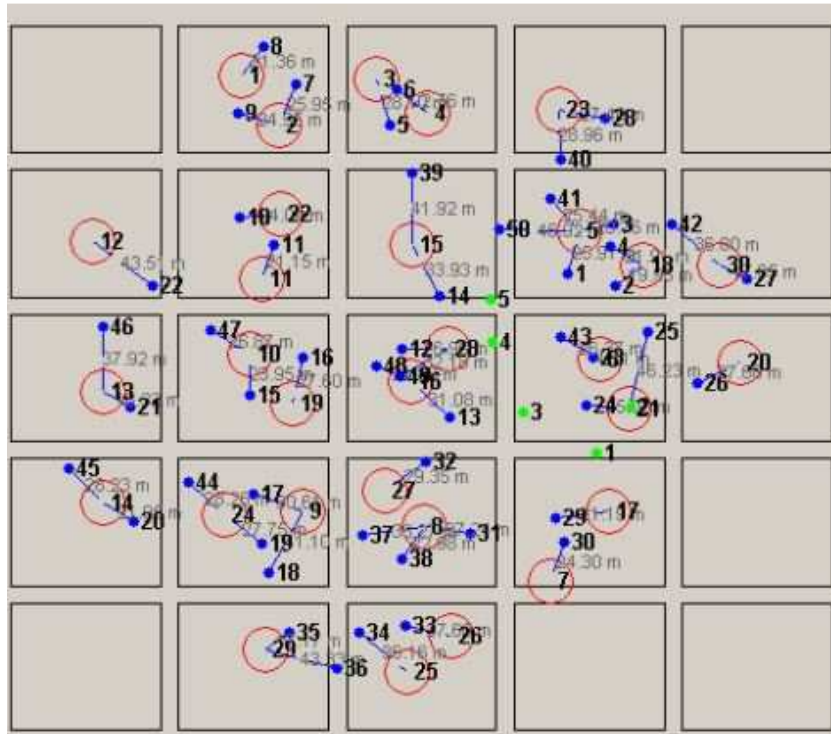

Fig 6-1 Topology with 30 Femtocells

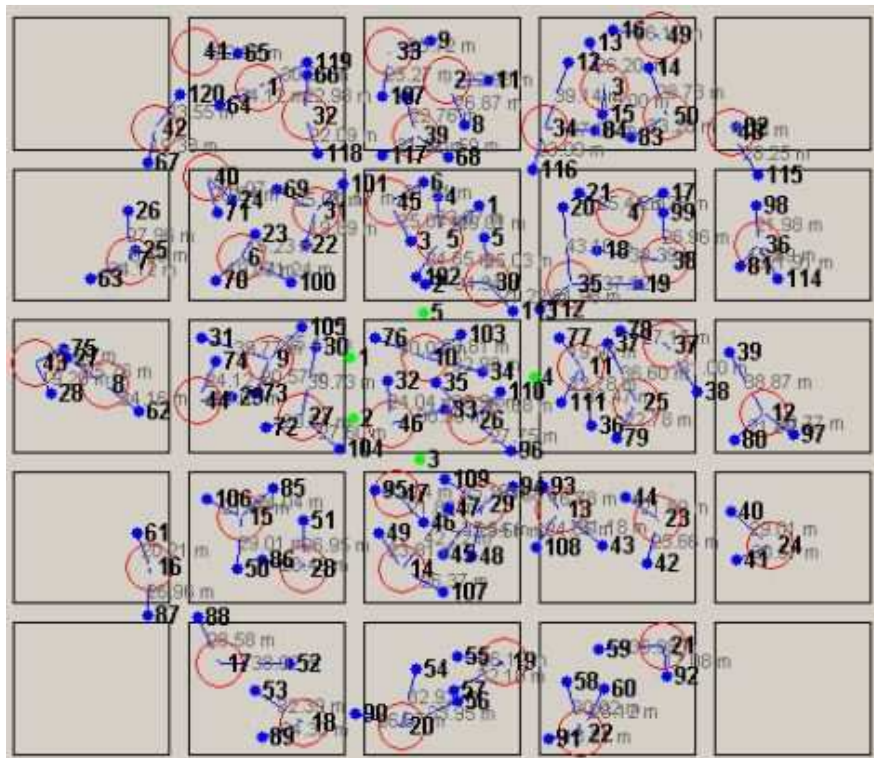

Fig 6-2 Topology with 50 Femtocells

6.3 Results

In this section, all the plots are shown with respect to the implementation of Carrier Aggregation, Carrier Aggregation along with Co-Ordinated Multipoint transmission/reception. These techniques are implemented to show how these technologies would vary against the conventional scheme and its benefits in terms of capacity, SNR and bandwidth utilization are highlighted.

6.3.1 CDF of Throughput (bps)

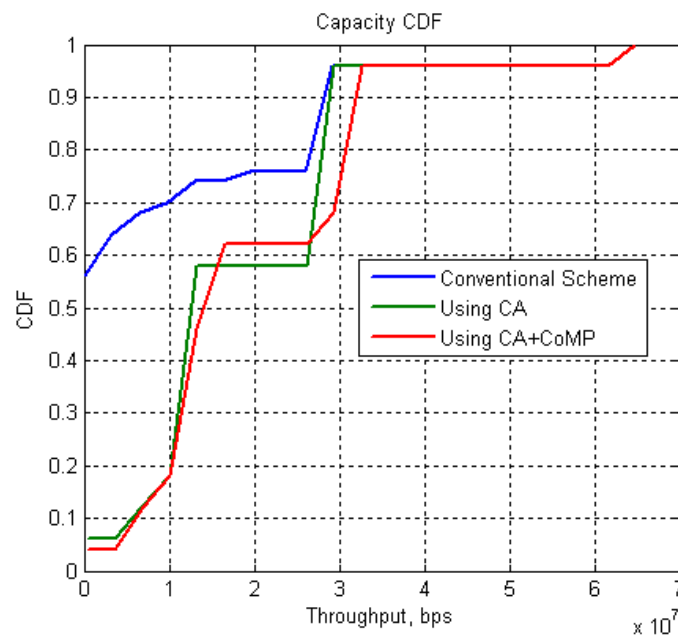

Fig 6-3 CDF of Throughput (BW – 20MHz, Femtocells - 30)

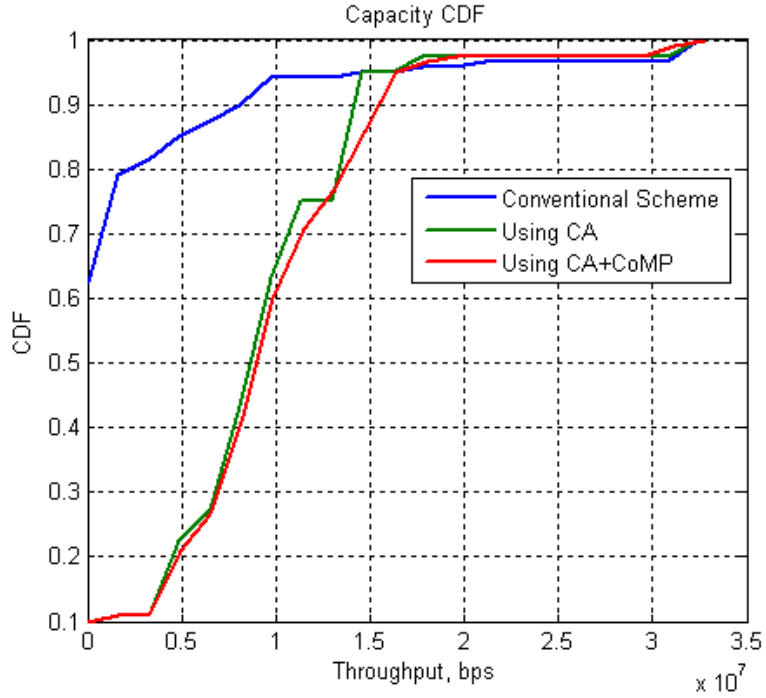

Fig 6-4 CDF of Throughput (BW – 20MHz, Femtocells - 50)

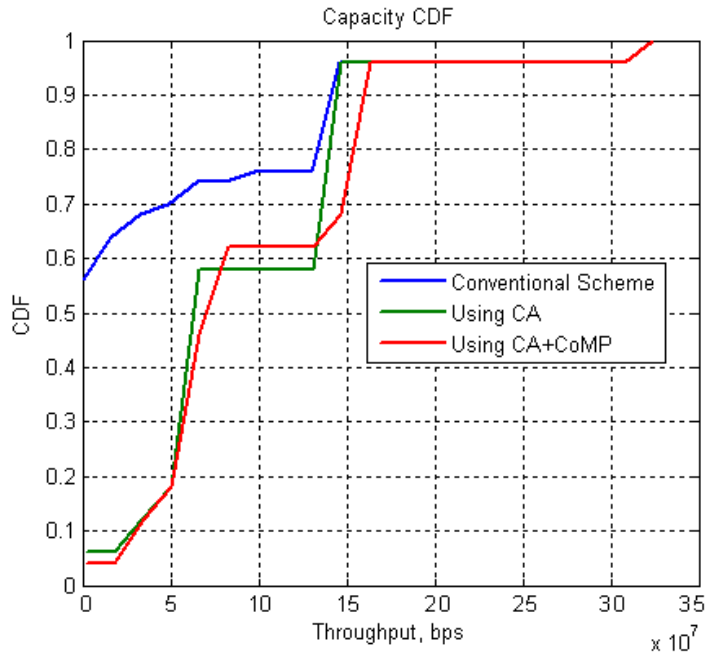

Fig 6-5 CDF of Throughput (BW – 100MHz, Femtocells - 30)

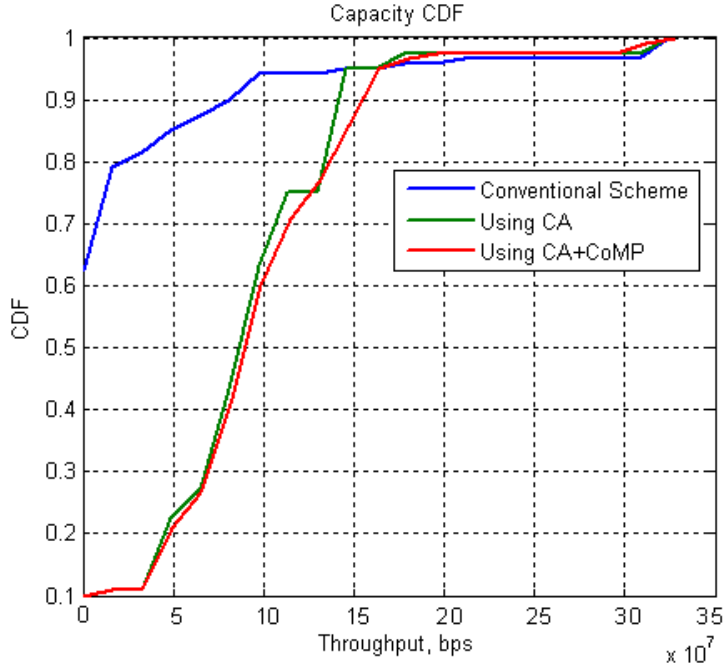

Fig 6-6 CDF of Throughput (BW – 100MHz, Femtocells - 50)

Cumulative Distribution Function (CDF) is the probability of Variate X, taking on a number that is less than or equal to number X. This may also be known as the “area in so far” function. At each possible value on the cumulative distribution function, it has the possibility of receiving a value that is less than one. CDF is given as:

$$F_x(x) = P(X \leq x)$$

$$P(a < X < b) = F_x(b) - F_x(a)$$

The right hand side in the above equation is the probability that the random variable of X, will take on a value that is less than x.

For the plots 6-2 – 6-6, the distribution is calculated with 20bins, or 20 divisions of the total obtained throughput with a step of (max-min)/20. For each bin, the number of users is counted, creating the probability density function. This is then integrated from 0 to maximum (throughput) and then is divided with the total number of users to give a probability value (≤ 1). If any 1 point is considered, then the Y-coordinate of that point on the cdf plot will depict the % of users below the throughput stated on X-coordinate.

Plots 6-3 and 6-4 represent the CDF of the throughput for 30 and 50 femtocells respectively, the bandwidth considered here is 20MHz (In accordance with LTE standard), while plots 6-5 and 6-6 represent the throughput for 30 and 50 femtocells respectively, but the bandwidth considered here is 100MHz (In accordance with LTE-A standard). We can see from the plots the proposed scheme with CA or with CA & CoMP perform much better when compared to the conventional scheme.

6.3.2 Throughput (bps) vs. Distance (m)

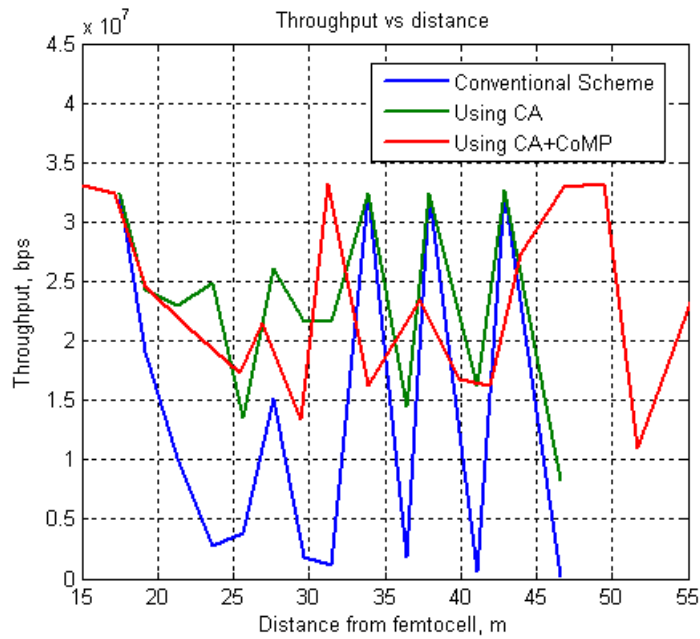

Fig 6-7 Throughput vs. Distance (BW – 20MHz, Femtocells - 30)

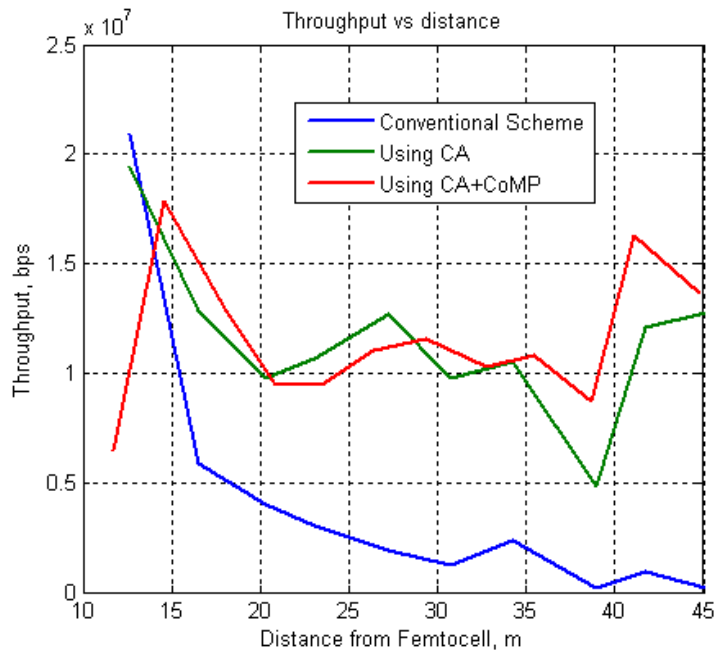

Fig 6-8 Throughput vs. Distance (BW – 20MHz, Femtocells - 50)

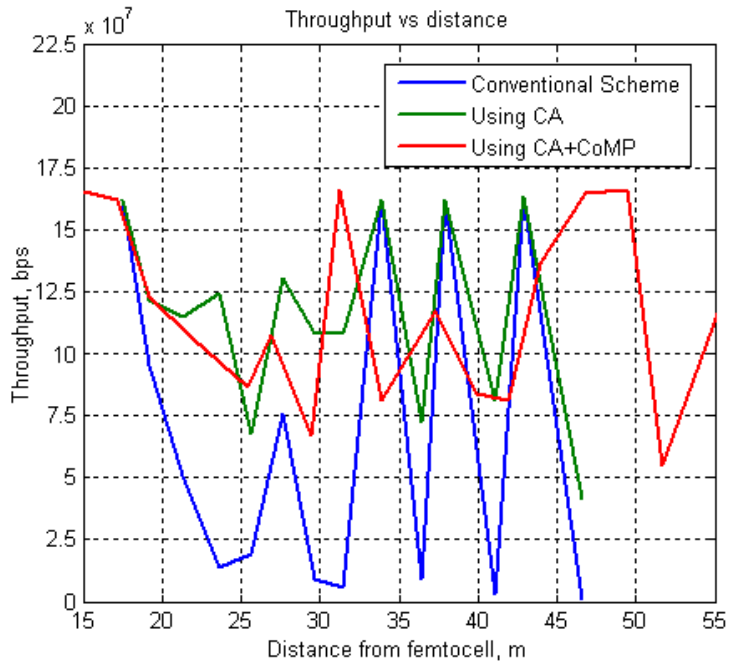

Fig 6-9 Throughput vs. Distance (BW – 100MHz, Femtocells – 30)

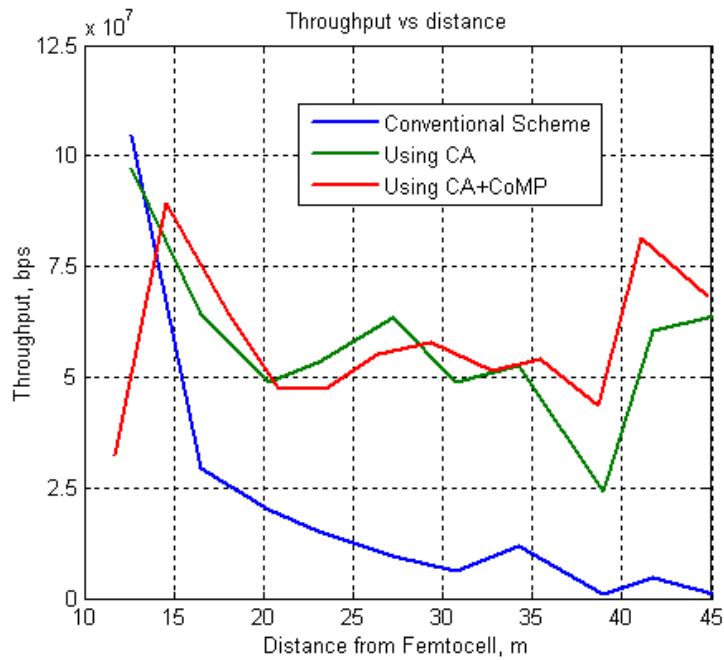

Fig 6-10 Throughput vs. Distance (BW – 100MHz, Femtocells - 50)

The plots shown from Fig 6-6 to Fig 6-10 depict the Throughput vs Distance. We can see from the above schemes, that the conventional scheme offers higher throughput for some users, at the same time there are many users who suffer from interference, thus there are lot of outages at the expense of higher peak capacity. So the proposed scheme with CA and with CA + CoMP reduces the total number of outages at the expense of providing slightly lower peak capacity. This can be seen when the user is very close to the femtocell. Lower peak capacity still falls within the throughput guaranteed to the user. This scheme is implemented assuming all the femtocells are active at the same time. So during different periods of the day, when the all the femtocells might not be active, the peak capacity per throughput will increase still maintaining the guaranteed throughput for all users.

6.3.3 SNR (dB) vs. Throughput (bps)

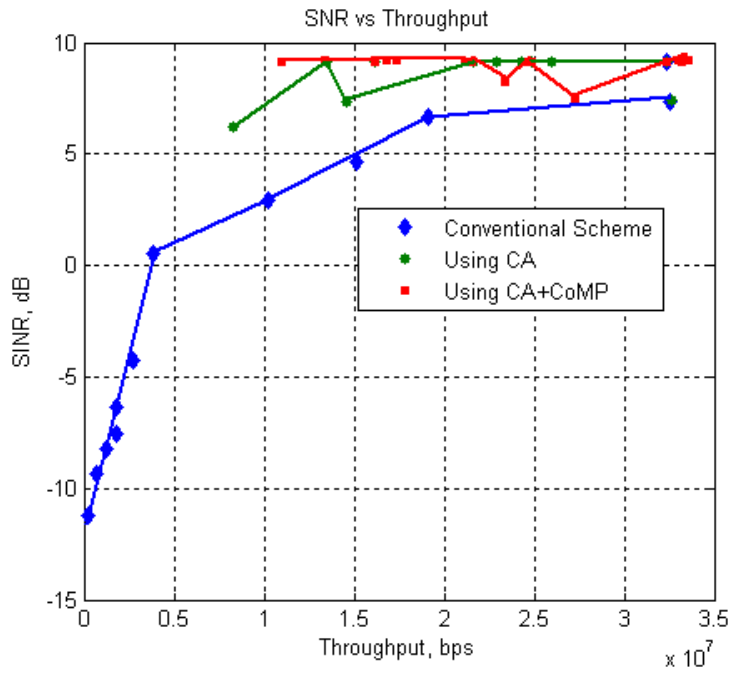

Fig 6-11 SNR vs. Throughput (BW – 20MHz, Femtocells - 30)

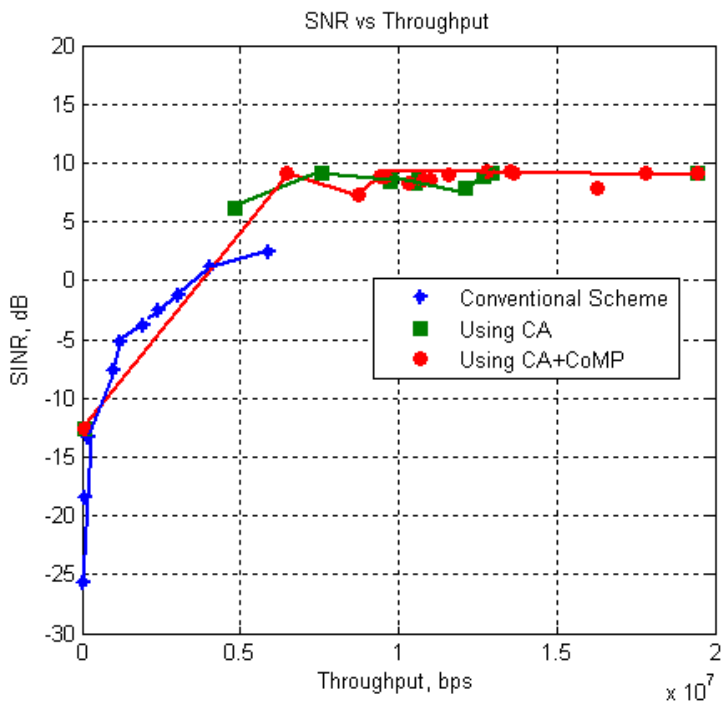

Fig 6-12 SNR vs. Throughput (BW – 20MHz, Femtocells - 50)

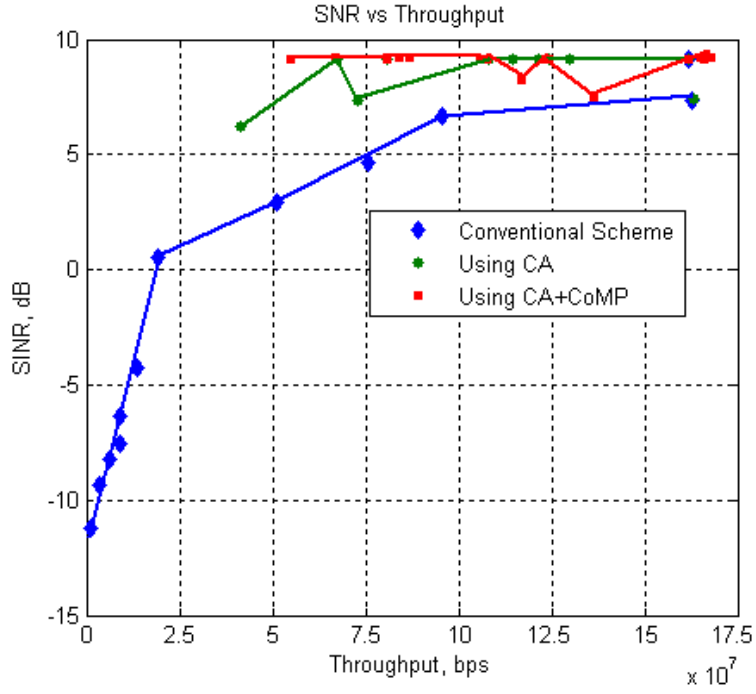

Fig 6-13 SNR vs. Throughput (BW – 100MHz, Femtocells - 30)

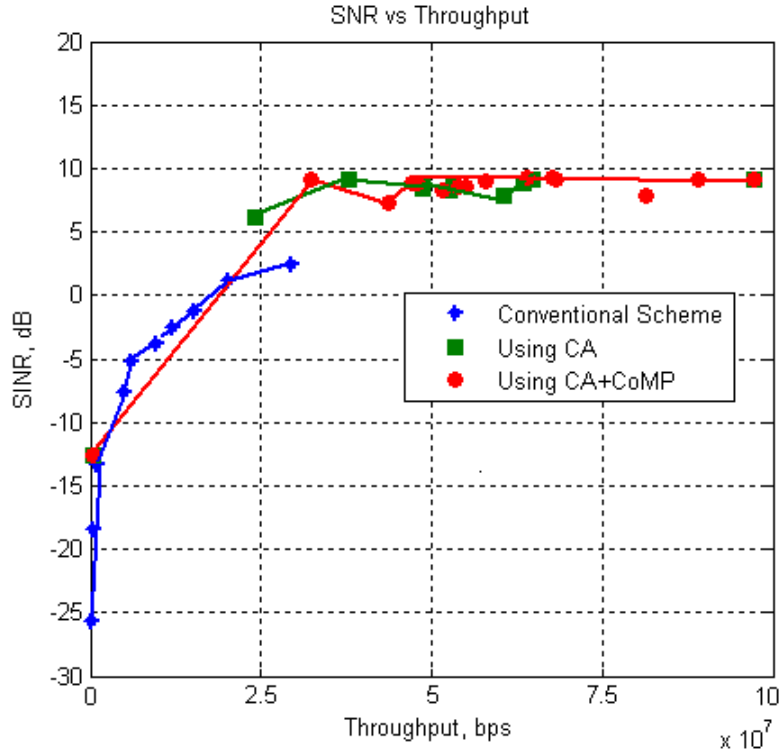

Fig 6-14 SNR vs. Throughput (BW – 100MHz, Femtocells - 50)

In the plots SNR vs. Throughput, the throughput values corresponding to the SNR are plotted. The plot 6-11 and plot 6-12 are when bandwidth is 20MHz (According to the LTE standard). In the plots 6-13 and 6-14 the throughput gets scaled by 5 times more i.e. 5 times more data rate, this is because the number of component carriers used in LTE-A are 5 when compared to 1 in LTE. The proposed bandwidth in LTE-A for downlink transmission is 100MHz.

The proposed techniques fares much better than the conventional system, the number of outages for a conventional system is very high as the users are prone to a lot of interference and this hampers the performance to a large extent even though the bandwidth is on the higher side. The whole point if femtocell is to provide the user with dedicated services. But due to the presence of so high interference, the whole purpose of a femtocell is defeated. The proposed techniques make sure all the users get a guaranteed SNR value irrespective of the distance. This is evident from observing the plots 6-11 to plots 6-14

6.3.4 Bandwidth efficiency (η)

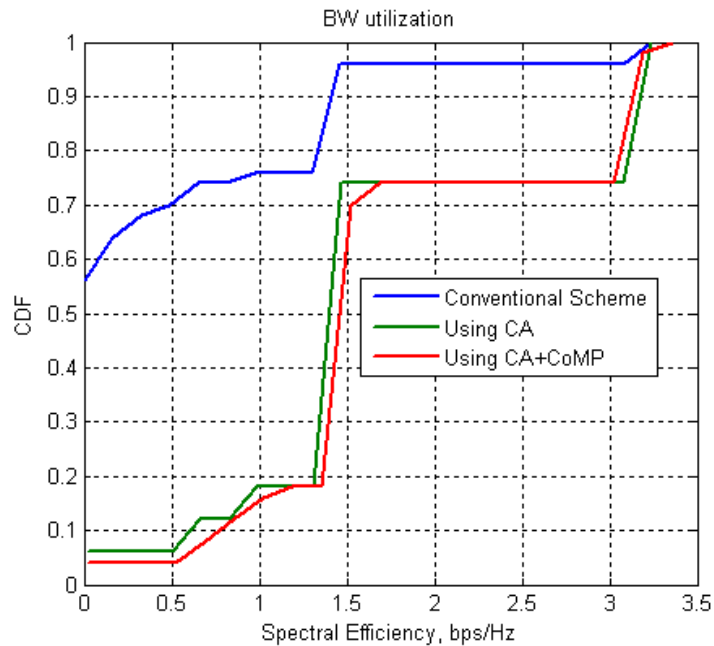

Fig 6-15 Bandwidth Efficiency (BW – 20MHz, Femtocells - 30)

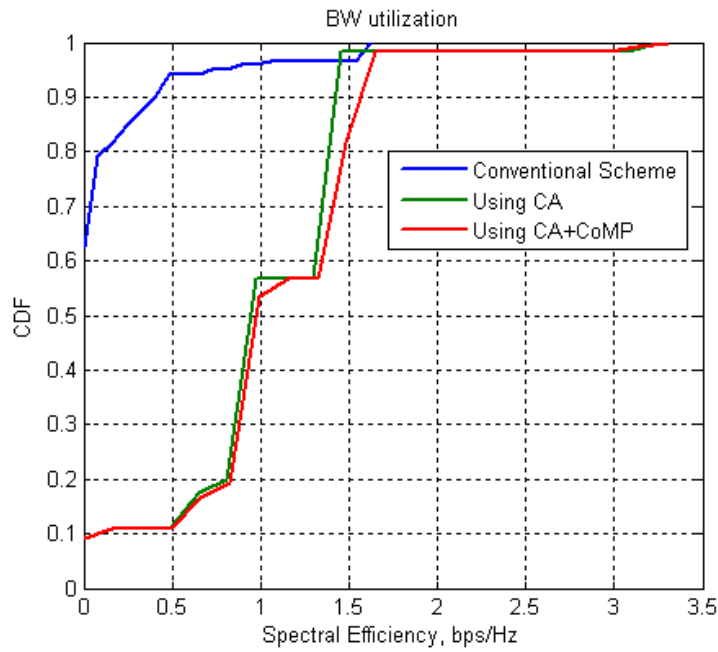

Fig 6-16 Bandwidth Efficiency (BW – 20MHz, Femtocells – 50)

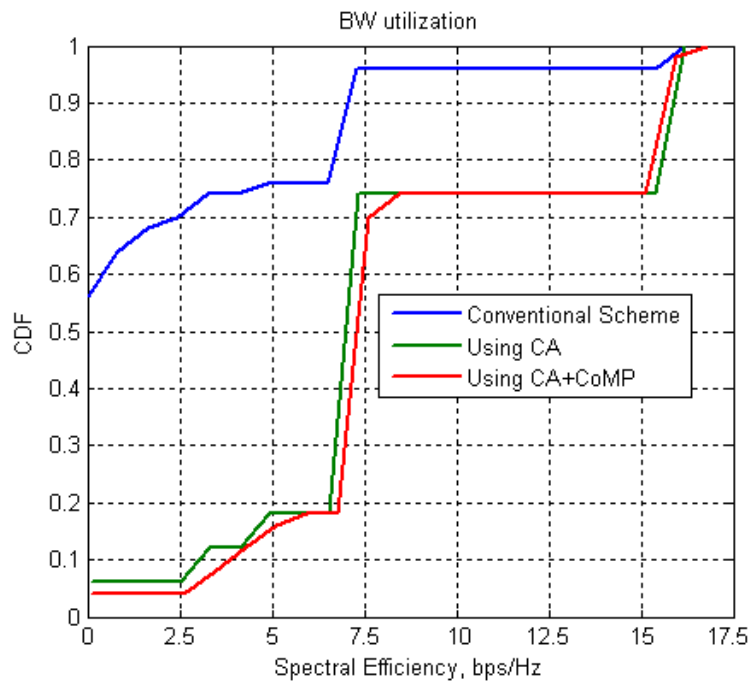

Fig 6-17 Bandwidth Efficiency (BW – 100MHz, Femtocells - 30)

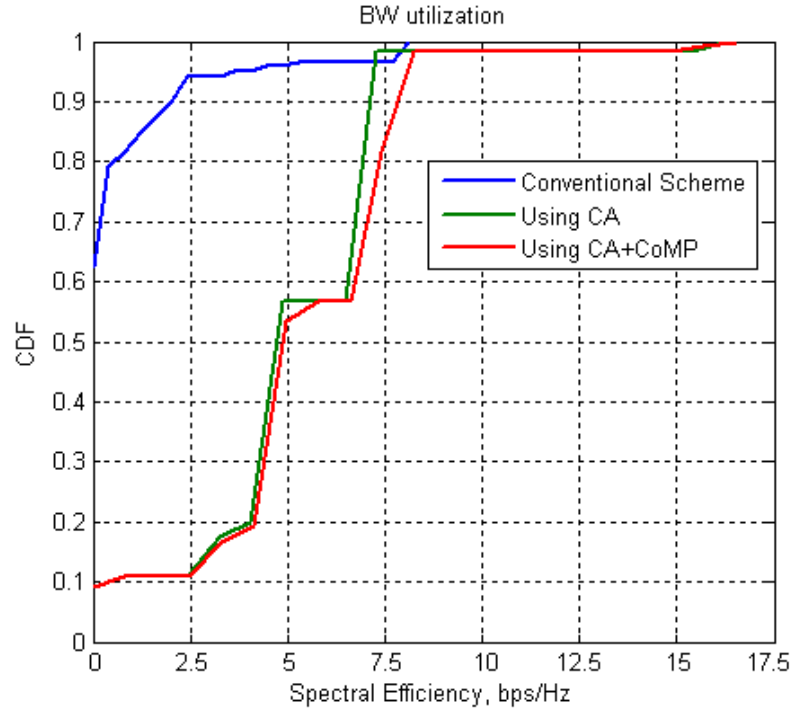

Fig 6-18 Bandwidth Efficiency (BW – 100MHz, Femtocells - 50)

Bandwidth Utilization or Bandwidth Efficiency refers to the information rate that can be transmitted over a given bandwidth in a specific communication system. It is a measure of how efficiently a limited frequency spectrum is utilized. It is also referred as the useful information rate transmitted over a certain bandwidth. For obtaining the plot shown in the figure 6-15 to 6-18, for each user, the number of sub-bands he is using is considered and the capacity is obtained accordingly. This capacity is divided by the bandwidth (total bandwidth is 20MHz or number of subcarriers) to get the spectral efficiency. This vector is split into 20 bins, number of users in each bin is counted and integrated to get the CDF. CDF is divided by the total number of femtousers to get the probability CDF. The proposed techniques CA or CA + CoMP perform noticeably when compared to the conventional scheme. Ex. In the plot 6.17, for spectral efficiency of 7.5 the CA + CoMP technique's probability of success is 70%, followed by CA technique's of 72% and the conventional scheme is merely less than 10%. This shows a significant gain when compared to the conventional scheme.

Chapter 7

Conclusion and Futurework

7.1 Conclusion

Femtocells are an integral part of the LTE-A heterogeneous networks as documented according to LTE-A standards. They promise superior increase in the throughput and reduced latencies to the customers. These however come at a risk of high interference due to which indoor users observe lot of outage. In such a scenario, the whole purpose of providing indoor base stations is defeated.

The main purpose of this thesis was to design a scheme where this interference is mitigated, providing the user favorable signal to noise ratio values thus giving the user high throughput, which in turn increases the overall capacity. To achieve the required, Carrier Aggregation (CA) along with Co-Ordinated Multipoint transmission/reception (CoMP) technologies as described in the LTE-Advanced features specified by IMT-A are used.

An open source system level simulator is used. The simulator's framework consists of a macrocell with multiple femtocells embedded in it. The user has the freedom to place these femtocells, macro users, femto users at any point in the topology. Various other factors such as the modulation scheme, the road width, number of buildings in the x and y axis are also to be entered by the user in the provided graphical user interface. Metrics such as SNR, throughput, distance from the femtocell, CDF are considered to highlight the difference in the performance between the conventional scheme and the scheme proposed in this thesis. The plots in the chapter "Results & Analysis" show a significant performance increase when compared with the conventional scheme. The conventional scheme provides higher throughput to those users who are not affected by any interference and very low throughput and outage for many users who are affected by interference. The proposed scheme reduces these outages by carefully allocating the sub-channels to all the users, thus providing a guaranteed throughput irrespective of their distances from femtocell.

CA in collaboration with CoMP fares slightly better when CA is used alone, however CA used with CoMP will show better results when there are more than 1 CoMP users per H-eNB. For simplicity purpose only one CoMP user per H-eNB is considered. To conclude Carrier Aggregation along with Co-Ordinated Multipoint transmission/reception show superior performance and these are illustrated by the help of performance metrics.

7.2 Futurework

With reference to the future work, more macro cells along with higher number of macrocell users should be considered and schemes need to be designed to reduce these cross-layer interferences. MIMO increases the throughput considerably, by exploring the advantages of the space time coding schemes. These multiple antennas have to be incorporated into these femtocell networks, to see how the performance increases.

The downside to this technology is the increase in overall complexity due to CA and CoMP. Due to dynamic allocation of subcarriers, the complexity involved will be on the higher side. Future studies can also be focused on lowering this complexity, reducing the overhead and making the process even simpler thus exerting less pressure/lower strain on overall resources. With the rapid increase in the usage of smartphones and due to need for higher data rates, even more enhanced techniques would be needed to reach higher speeds and reduce latency.

References

- [1] Stefania Sesia, Issam Toufik and Matthew Baker. *LTE - The UMTS Long term Evolution from Theory to Practice*, 2009
- [2] John G. Proakis, Masoud Salehi and Gerhard Bauch. *Contemporary Communications using Matlab*, 2004
- [3] Jie Zhang and Guillaume de le Roche. *Femtocells - Technologies and Deployment*, 2010
- [4] Simon R Saunders and Stuart Carlaw. *Femtocells - Opportunities and Challenges for Business and Technology*, 2009
- [5] Bo Li, *An effective Inter-Cell Interference Interference Coordination Scheme for Heterogeneous network*. IEEE 2011
- [6] Stefan Brueck, *Heterogeneous Networks in LTE - Advanced*, 8th International Symposium on Wireless Communication Systems, Aachen IEEE 2011
- [7] Liya Yi and Tao Cui, *Interference Mitigation between Femtocell and Macrocell (The Coming of Attocell)*. 2011 International Conference on Electronics and Optoelectronics (ICEOE 2011)
- [8] Su Huan, Kuang Linling and Lu Jianhua, *Interference Avoidance in OFDMA - Based Femtocell Network*. IEEE 2009
- [9] Avani Dalal, Hailong Li and Dharma P. Agawal, *Fractional Frequency Reuse to Mitigate Interference in Self-Configuring LTE-Femtocells Network*, 8th IEEE International Conference on Mobile Ad-Hoc and Sensor Systems, 2011
- [10] Noriaki Miyazaki, Xiaoqiu Wang, Masashi Fushiki and Satoshi Konishi, *Interference Coordination of the Downlink Control Channel under Macro-Femto Deployment in Long Term Evolution*, 8th International Symposium on Wireless Communication Systems, Aachen 2011

- [11] Hyung G. Myung, Junsung Lim, and David J. Goodman, "Single Carrier FDMA for Uplink Wireless Transmission," *IEEE Vehicular Magazine*, vol. 1, no. 3, September 2006.
- [12] C. Gessner, "UMTS Long Term Evolution LTE Technology Introduction," Rohde & Schwarz, 2007.
- [13] 3GPP LTE - Long Term Evolution. [Online]. <http://3gppltelongtermevolution.blogspot.com/2010/06/introduction-to-lte.html>
- [14] v8.5.0 3GPP TS 36.300, "E-UTRA and E-UTRAN, Overall Description; Stage 2 (Release 8)," 2008.
- [15] LTE-A Femto-Macro Throughput Simulator.
http://ru6.cti.gr/ru6/femtomacro_throughput_simulator.zip

Biographical Information

Rohan Nag Kummithe completed his Bachelor of Engineering from Visvesvaraya Technological University, Karnataka, India in 2009. He then chose to pursue his graduate studies in the Department of Electrical Engineering at The University of Texas at Arlington in Fall 2010. During the course of his graduate studies he worked under the guidance of Dr. Qilian Liang in the Wireless Communication and Networking Lab. He interned at Motorola Mobility at Libertyville, Illinois during Fall 2011 and Spring 2012.